

Chapter 14

BASTROP DEVELOPMENT CODE

Table of Contents

Chapter 14 BASTROP DEVELOPMENT CODE.....	1
ARTICLE 14.01 GENERAL PROVISIONS.....	5
Sec. 14.01.001 Title, Authority, and Purpose.....	5
Sec. 14.01.002 Applicability and Jurisdiction.....	5
ARTICLE 14.02 ZONING DISTRICTS	7
Sec. 14.02.001 Establishment of Zoning Districts.....	7
Sec. 14.02.002 Official Zoning Map.....	7
Sec. 14.02.003 District Requirements.....	7
Sec. 14.02.004 Development Patterns.....	23
Sec. 14.02.005 Restrictions on Dwellings.....	26
Sec. 14.02.006 Contextual Neighborhood Setback Adjustment	27
Sec. 14.02.007 Highway Corridor Setbacks	28
Sec. 14.02.008 Table of Permitted Uses.....	30
ARTICLE 14.03 SPECIAL DISTRICTS AND OVERLAYS.....	37
Sec. 14.03.001 District 1832.....	37
Sec. 14.03.002 Downtown Bastrop	38
Sec. 14.03.003 Downtown Historic District.....	40
ARTICLE 14.04 DEVELOPMENT STANDARDS	42
Sec. 14.04.001 Site Design	42
Sec. 14.04.002 Sidewalks and Pedestrian Connectivity Standards.....	46
Sec. 14.04.003 Outdoor Lighting.....	49
Sec. 14.04.004 Off-Street Parking, Loading, and Bicycle Parking Standards.....	60
Sec. 14.04.005 Access and Connectivity.....	64
Sec. 14.04.006 Accessory Uses and Structures.....	70
ARTICLE 14.05 LANDSCAPING REQUIREMENTS	74
Sec. 14.05.001 Minimum On-Site Landscaping Requirements	74
Sec. 14.05.002 Low Impact Development Landscaping Credits.....	83
Sec. 14.05.003 Adopted Lists	84
ARTICLE 14.06 TREE PRESERVATION AND MITIGATION.....	85
Sec. 14.06.001 Purpose and Intent	85
Sec. 14.06.002 Applicability and Relationship to Other Codes	85
Sec. 14.06.003 Permit Requirement and Validity	85
Sec. 14.06.004 Submittals: Tree Survey and Removal/Preservation Plan	85

Sec. 14.06.005 Credits.....	86
Sec. 14.06.006 New and Replacement Tree Standards	86
Sec. 14.06.007 Root Protection Zones	87
Sec. 14.06.008 Mitigation, Replacement Calculation, and Payment in Lieu	88
Sec. 14.06.009 Appeals	89
Sec. 14.06.010 Exemptions	89
Sec. 14.06.011 Fees and Penalties	90
ARTICLE 14.07 SIGNS.....	92
Sec. 14.07.001 Intent & Purpose.....	92
Sec. 14.07.002 Applicability & Jurisdiction.....	92
Sec. 14.07.003 Administration	92
Sec. 14.07.004 General Standards	92
Sec. 14.07.005 Measurement	93
Sec. 14.07.006 Illumination.....	93
Sec. 14.07.007 Permanent Signs	93
Sec. 14.07.008 Temporary Signs	95
Sec. 14.07.009 Prohibited Signs/Practices	95
Sec. 14.07.010 Nonconforming, Nuisance, and Removal	96
Sec. 14.07.011 Dimensional Standards & Permissions	96
Sec. 14.07.012 Sign Board; Administrative Relief; Variances and Appeals.....	97
Sec. 14.07.013 Murals as Public Art	100
ARTICLE 14.08 CODE ENFORCEMENT & NONCONFORMITIES	104
Sec. 14.08.001 Authority, Purpose, and Applicability	104
Sec. 14.08.002 Administration	104
Sec. 14.08.003 Zoning Notice of Violation (NOV)	104
Sec. 14.08.004 Zoning Stop-Work Orders	105
Sec. 14.08.005 Nonconformities—General.....	105
Sec. 14.08.006 Nonconforming Uses	105
Sec. 14.08.007 Nonconforming Structures	106
Sec. 14.08.008 Restoration After Casualty.....	106
Sec. 14.08.009 Nonconforming Lots (Lots of Record).....	106
Sec. 14.08.010 Redevelopment and Expansion of Nonconforming Sites	106
Sec. 14.08.011 Manufactured Home Communities (Special Rule).....	109
Sec. 14.08.012 Violations; Relationship to Other Enforcement.....	109
ARTICLE 14.09 HISTORIC PRESERVATION ORDINANCE	110
Sec. 14.09.001 Purpose and Intent.	110
Sec. 14.09.002 Historic Landmark Commission.	110

Sec. 14.09.003 Appointment of Historic Preservation Officer.....	111
Sec. 14.09.004 Categories of Preservation.....	111
Sec. 14.09.005 Process for Designation of Historic Landmarks.	112
Sec. 14.09.006 Process for Removal of Historic Landmark Designation.	112
Sec. 14.09.007 Criteria for Creation of Historic Districts.....	113
Sec. 14.09.008 Process for the Designation of Local Historic District.	113
Sec. 14.09.009 Relationship of Designations to Zoning.	114
Sec. 14.09.010 Certificate of Appropriateness.....	114
Sec. 14.09.011 COA Required for Demolition or Relocation.....	119
Sec. 14.09.012 Failure to Maintain Resulting in Demolition by Neglect.	121
Sec. 14.09.013 Incentives for Historic Landmarks.....	122
Sec. 14.09.014 Economic Hardship.	125
Sec. 14.09.015 Penalties.	126
ARTICLE 14.10 SPECIAL FLOOD HAZARD AREA.....	127
Sec. 14.10.001 Purpose and Authority.....	127
Sec. 14.10.002 Development Requirements and Restrictions.....	128
Sec. 14.10.003 Variances and Appeals.....	130
Sec. 14.10.004 Definitions.....	130
ARTICLE 14.11 PLANNING AND ZONING COMMISSION.....	131
Sec. 14.11.001 General.....	131
Sec. 14.11.002 Members, Officers, and Alternatives Qualifications.....	131
Sec. 14.11.003 Quorum and Voting.....	131
Sec. 14.11.004 Meetings:.....	132
Sec. 14.11.005 Powers and Duties:.....	132
Sec. 14.11.006 Procedure on Zoning Hearings:.....	132
ARTICLE 14.12 ZONING BOARD OF ADJUSTMENTS.....	133
Sec. 14.12.001 Creation, Applicability, and Exemptions:.....	133
Sec. 14.12.002 Membership; Terms of Office.....	134
Sec. 14.12.003 Authority of the Board.....	134
Sec. 14.12.004 Quorum and Voting.....	134
Sec. 14.12.005 Variances.....	134
Sec. 14.12.006 Nonconforming Uses and Structures.....	135
Sec. 14.12.007 Procedure for Variances.....	136
Sec. 14.12.008 Appeals of Administrative Decisions.....	136
Sec. 14.12.009 Judicial Review of Board Decisions.....	137
Sec. 14.12.010 Fees:.....	137
ARTICLE 14.13 ADMINISTRATION AND PROCEDURES.....	138

Sec. 14.13.001 Development Process	138
Sec. 14.13.002 Zoning Procedures	143
Sec. 14.13.003 Administrative Relief.	146
Sec. 14.13.004 Site Development Plans	148
Sec. 14.13.005 Conditional Uses	151
Sec. 14.13.007 Filing & Notice Requirements	154
Sec. 14.13.008 Public Hearing Procedures	157
Sec. 14.13.009 Fees	158
ARTICLE 14.14 DEFINITIONS	159
Sec. 14.14.001 Purpose; Use of Definitions.	159
ARTICLE 14.15 APPENDICES	173
Appendix A – Protected Trees, Accepted Native Plants, and Invasive Species List	173
Appendix B – Preferred Plant List	174
Appendix C – Site Development Plan Checklist.....	175
Appendix D – Design Guidelines	191

ARTICLE 14.01 GENERAL PROVISIONS

Sec. 14.01.001 Title, Authority, and Purpose.

- A. Title. This ordinance shall be known and cited as the City of Bastrop Development Code (the “Development Code”).
- B. Authority. This Development Code is adopted pursuant to the City of Bastrop’s authority as a Home-Rule Municipality under the Texas Constitution, the Texas Local Government Code (including Chapters 51, 54, 211, 212, and 213), and other applicable state and federal laws.
- C. Purpose.
 - 1) The purpose of this Development Code is to establish a comprehensive framework of standards for land use, development, and redevelopment within the City of Bastrop and its extraterritorial jurisdiction.
 - 2) This Code is intended to:
 - a) Implement the City’s Comprehensive Plan and adopted policies;
 - b) Guide growth in a fiscally sustainable and geographically sensitive manner;
 - c) Preserve and reflect Bastrop’s authentic character and historic development patterns;
 - d) Provide clear, consistent, and predictable standards for property owners, developers, and the community;
 - e) Promote environmental stewardship and resilience, including flood mitigation and sustainable land use practices;
 - f) Ensure high-quality, intentional development that contributes to a strong sense of place, economic vitality, and community identity; and
 - g) Protect the health, safety, and general welfare of the residents of Bastrop.

Sec. 14.01.002 Applicability and Jurisdiction.

- A. Applicability.
 - 1) The provisions of this Development Code shall apply to all land, structures, uses, and development activities within the jurisdiction of the City of Bastrop as described in subsection B.
 - 2) No building, structure, land, or use shall be established, constructed, altered, or maintained unless in compliance with the provisions of this Code and all other applicable City ordinances and regulations.
 - 3) Where conflicts arise between this Code and other ordinances, the more restrictive provision shall govern unless otherwise expressly stated.
- B. Jurisdiction.
 - 1) This Development Code applies to all property within the corporate limits of the City of Bastrop.

- 2) Certain provisions of this Code, as authorized by the Texas Local Government Code, shall also apply within the City's extraterritorial jurisdiction (ETJ), including, but not limited to, subdivision regulation, infrastructure standards, environmental protection, and other provisions expressly authorized by law.
- 3) The boundaries of the City and its ETJ shall be determined as provided by state law and as may be amended from time to time through annexation, disannexation, or other lawful action.

ARTICLE 14.02 ZONING DISTRICTS

Sec. 14.02.001 Establishment of Zoning Districts.

A. The City of Bastrop is hereby divided into the following zoning districts. Each district is intended to guide land development in a manner consistent with the Comprehensive Plan and the unique character of Bastrop. These districts establish the baseline for permitted uses, development intensity, and design standards.

The zoning districts established in this Code are:

- P/OS – Parks and Open Space
- RR – Rural Residential
- SF-1 – Low Density Single Family Residential
- SF-2 – Medium Density Single Family Residential
- SF-3 – High Density Single Family Residential
- MU – Mixed Use
- GC – General Commercial
- PI – Public Institutional
- IND – Industrial
- PDD – Planned Development Districts

Sec. 14.02.002 Official Zoning Map.

The location and boundaries of zoning districts shall be shown on the Official Zoning Map of the City of Bastrop and incorporated herein by reference as Reference A. The Official Zoning Map shall be maintained by the Development Services Department and is incorporated herein by reference and kept on file with the City Secretary and Development Services Department.

Sec. 14.02.003 District Requirements

A. Parks and Open Space (P/OS)

- 1) Intent. The P/OS District preserves land for natural areas, greenways, floodplains, public parks, and recreational facilities. It provides areas for conservation, passive and active recreation, and environmental protection while maintaining Bastrop's natural character and sensitive environmental features.
- 2) Typical Uses: Parks, trails, greenways, floodplain reserves, civic plazas, nature preserves, cemeteries, and limited accessory structures (restrooms, pavilions).
- 3) Dimensional Standards Chart:

Standard	Requirement
Minimum Lot Size	None
Minimum Lot Width	None
Front Setback	None
Side Setback	None; 15 feet when abutting residential district.
Corner Side Street Setback	None
Rear Setback	None; 15 feet when abutting residential district.
Accessory Structure Setbacks	As listed in Sec. 14.04.006
Maximum Building Height	35 feet
Maximum Impervious Coverage	None; however development must comply with drainage requirements.
Parking Requirements	As determined by the Parks and Recreation Director

B. Rural Residential (RR)

- 1) Intent. The RR District accommodates very low-density residential and agricultural uses. It preserves Bastrop’s rural heritage, maintains open vistas, and provides a transition from natural areas to developed areas, supporting large-lot homesteads, ranching, and agricultural operations.
- 2) Typical Uses: Single-family dwellings (detached) or duplexes, on large lots, ranching, farming, equestrian uses, and rural community facilities.
- 3) Dimensional Standards Chart:

Standard	Requirement
Minimum Lot Size	1 acre (43,560 sq. ft.)
Minimum Lot Width	150 feet
Front Setback	50 feet
Side Setback	20 feet
Corner Side Street Setback	20 feet
Rear Setback	50 feet
Accessory Structure Setbacks	As listed in Sec. 14.04.006
Maximum Building Height	35 feet (2.5 stories)
Maximum Impervious Coverage	50%
Parking Requirements	One (1) 10’ x 20’ parking space per bedroom shall be provided.

C. Residential Single Family – Low Density (SF-1)

- 1) Intent. A district for detached single-family dwelling on larger lots, offering a spacious, low-intensity residential setting with a suburban-to-rural feel.
- 2) Typical Uses: Single-family dwellings (detached) and no-impact home-based businesses.
- 3) Dimensional Standards Chart:

Standard	Requirement
Minimum Lot Size	1/3 acre (14,520 sq. ft.)
Minimum Lot Width	100 feet
Front Setback*	30 feet
Side Setback	10 feet
Corner Side Street Setback	20 feet
Rear Setback	30 feet
Accessory Structure Setbacks	As listed in Sec. 14.04.006
Maximum Building Height	35 feet (2.5 stories)
Maximum Impervious Coverage	50%
Parking Requirements	One (1) 10' x 20' parking space per bedroom shall be provided.

*Unless adjusted by an overlay district.

D. Residential Single Family – Medium Density (SF-2)

- 1) Intent. A district for detached single-family homes on mid-sized lots, reflecting a classic neighborhood pattern with balanced density and everyday livability.
- 2) Typical Uses: Single-family dwellings (detached) and no-impact home-based businesses.
- 3) Dimensional Standards Chart:

Standard	Requirement
Minimum Lot Size	7,500 sq. ft.
Minimum Lot Width	75 feet
Front Setback*	25 feet
Side Setback	7.5 feet
Corner Side Street Setback	15 feet
Rear Setback	20 feet
Accessory Structure Setbacks	As listed in Sec. 14.04.006
Maximum Building Height	35 feet (2.5 stories)
Maximum Impervious Coverage	50%

Parking Requirements	One (1) 10' x 20' parking space per bedroom shall be provided.
-----------------------------	--

*Unless adjusted by an overlay district.

E. Residential Single Family – High Density (SF-3)

- 1) Intent. A district for detached single-family dwellings on smaller, more compact lots, supporting a finer-grained neighborhood fabric and efficient use of land while maintaining single-family character.
- 2) Typical Uses: Single-family dwellings (detached) and no-impact home-based businesses.
- 3) Dimensional Standards Chart:

Standard	Requirement
Minimum Lot Size	5,000 sq. ft.
Minimum Lot Width	50 feet
Front Setback*	15 feet
Side Setback	5 feet
Corner Side Street Setback	10 feet
Rear Setback	15 feet
Accessory Structure Setbacks	As listed in Sec. 14.04.006
Maximum Building Height	35 feet (2.5 stories)
Maximum Impervious Coverage	50%
Parking Requirements	One (1) 10' x 20' parking space per bedroom shall be provided.

*Unless adjusted by an overlay district.

F. Mixed Use (MU)

- 1) Intent: The MU District is intended to provide a variety of housing types at higher densities while allowing for limited neighborhood-serving commercial uses. This district promotes walkable, compact development that supports efficient infrastructure use and creates opportunities for residents to live, work, and access services within the same community. MU areas are typically located along corridors or at transitions between lower-density residential neighborhoods and more intense commercial or employment districts.
- 2) Typical Uses: Apartments, townhomes, duplexes, condominiums, senior housing, live/work units, and small-scale neighborhood-serving commercial such as retail, offices, restaurants, and personal services, along with supporting community amenities.
- 3) Dimensional Standards Chart – General MU Development:
The following standards apply to all development in the MU District except fee-simple townhomes and duplexes addressed in Subsection 4). These standards apply to apartments, mixed-use buildings, senior

housing, live/work, and non-residential uses, or to larger “parent tracts” on which attached housing is developed under common ownership (e.g., condominiums or rentals).

Standard	Requirement
Minimum Lot Size	1/3 acre (14,520 sq. ft.)
Minimum Lot Width	50 feet
Front Setback*	15 feet
Side Setback	5 feet minimum; 0 feet allowed on shared/party-wall sides within a unified development; 10 feet where abutting RR or SF districts.
Corner Side Street Setback	10 feet
Rear Setback	15 feet
Accessory Structure Setbacks	As listed in Sec. 14.04.006
Maximum Building Height	45 feet (4 stories)
Maximum Impervious Coverage	60%
Parking Requirements	One (1) 10' x 20' parking space per bedroom shall be provided for residential, see Parking Schedule in Section 14.04.004 for commercial off-street parking requirements.

*Unless adjusted by an overlay district.

4) Dimensional Standards Chart – Attached Residential Building Types:

The following standards apply to individually platted fee-simple townhome and duplex lots within the MU District. Where townhomes or duplexes are developed on a larger MU parent tract under single ownership (e.g., condos or rentals), the Director may apply either the general MU standards in Subsection 3) or the attached-residential standards in this Subsection, whichever better fits the development pattern.

a) Townhomes (fee-simple attached single-family).

Standard	Requirement	End/Corner Unit Lot
Minimum Lot Size	2,000 sq. ft.	2,400 sq. ft.
Minimum Lot Width	20 feet	24 feet
Front Setback*	10 feet	
Side Setback	0 feet on shared/common walls; 5 feet on non-attached sides	

Corner Side Street Setback	10 feet	
Rear Setback	10 feet (15 feet when abutting RR or SF districts)	
Accessory Structure Setbacks	As listed in Sec. 14.04.006	
Maximum Building Height	40 feet (3 stories)	
Maximum Impervious Coverage	60%	
Parking Requirements	One (1) 10' x 20' parking space per bedroom shall be provided for residential.	
Required Plat Note	Lots under 1/3 acre may only be used for townhomes or duplexes, lots under 4,000 sq. ft. may only be used for townhomes.	

*Unless adjusted by an overlay district.

b) Duplex (two dwelling units on one lot)

Standard	Requirement
Minimum Lot Size	4,000 sq. ft.
Minimum Lot Width	40 feet
Front Setback*	10 feet
Side Setback	5 feet
Corner Side Street Setback	10 feet
Rear Setback	10 feet (15 feet when abutting RR or SF districts)
Accessory Structure Setbacks	As listed in Sec. 14.04.006
Maximum Building Height	40 feet (3 stories)
Maximum Impervious Coverage	60%
Parking Requirements	One (1) 10' x 20' parking space per bedroom shall be provided for residential.
Required Plat Note	Lots under 1/3 acre may only be used for townhomes or duplexes, lots under 4,000 sq. ft. may only be used for townhomes.

*Unless adjusted by an overlay district.

G. General Commercial (GC)

- 1) Intent. The GC District provides for commercial, retail, office, and mixed-use development. It is intended to concentrate higher-intensity commercial activity in Bastrop’s downtown, corridors, and regional centers.
- 2) Typical Uses: Retail stores, restaurants, offices, personal and professional services, auto sales and service, hotels/motels, and similar commercial uses that serve both local and regional customers.
- 3) Dimensional Standards Chart

Standard	Requirement
Minimum Lot Size	¼ acre (10,890 sq. ft.)
Minimum Lot Width	75 feet
Front Setback*	20 feet
Side Setback	5 feet
Corner Side Street Setback	10 feet
Rear Setback	20 feet
Accessory Structure Setbacks	As listed in Sec. 14.04.006
Maximum Building Height	55 feet (5 stories)
Maximum Impervious Coverage	65%
Parking Requirements	See Parking Schedule in Section 14.04.004 for commercial off-street parking requirements.

*Unless adjusted by an overlay district.

H. Public Institutional (PI)

- 1) Intent. The PI District is reserved for civic, public, and institutional uses that serve the community.
- 2) Typical Uses: Schools, libraries, community centers, government buildings, and public safety facilities.
- 3) Dimensional Standards Chart

Standard	Requirement
Minimum Lot Size	1 acre
Minimum Lot Width	100 feet
Front Setback*	25 feet (may be reduced to 10 feet for urban frontage, provided fire access and pedestrian circulation are maintained).
Side Setback	15 feet
Corner Side Street Setback	20 feet

Rear Setback	20 feet
Accessory Structure Setbacks	As listed in Sec. 14.04.006
Maximum Building Height	55 feet (5 stories)
Maximum Impervious Coverage	65%
Parking Requirements	See Parking Schedule in Section 14.04.004 for commercial off-street parking requirements.

*Unless adjusted by an overlay district.

I. Industrial (IND)

- 1) Intent. The IND District provides locations for industrial and employment-generating uses that require larger sites, access to major transportation routes, and separation from residential neighborhoods.
- 2) Typical Uses: Warehousing, light and heavy industrial uses, logistics, distribution, manufacturing, and supporting offices.
- 3) Dimensional Standards Chart

Standard	Requirement
Minimum Lot Size	2.5 acres
Minimum Lot Width	100 feet
Front Setback*	25 feet
Side Setback	20 feet (40 feet when abutting a residential district)
Corner Side Street Setback	20 feet
Rear Setback	25 feet (40 feet when abutting a residential district)
Accessory Structure Setbacks	As listed in Sec. 14.04.006
Maximum Building Height	60 feet (5 stories)
Maximum Impervious Coverage	65%
Parking Requirements	See Parking Schedule in Section 14.04.004 for commercial off-street parking requirements.

*Unless adjusted by an overlay district.

J. Planned Development District (PDD)

- 1) Purpose and Nature of District.
 - a) Purpose. The Planned Development District (PD/PDD) is a legislative zoning district intended to allow integrated, creative development with equal or superior outcomes relative to base zoning, while protecting adjacent areas and natural resources.

- b) Legislative Nature. A PDD is established by ordinance. It is not a contract and does not bind future legislative action. Any companion development agreement, if used, is a separate instrument and may not substitute for or conflict with this ordinance.
 - c) Plan Consistency. Council may approve a PDD only upon finding it is in accordance with the Comprehensive Plan and advances the public health, safety, and welfare.
 - d) District Framework. Each PDD is a freestanding zoning district that (i) adopts a PD Master Plan and (ii) adopts a Development Standards Matrix regulating uses and form. Where the PDD is silent, the referenced base district applies.
- 2) Minimum Standards.
- a) Standards by ordinance. Standards are adopted by ordinance via the PD Master Plan and Development Standards Matrix. Where not modified, the referenced base district and this Code apply.
 - b) Land use.
 - (1) Uses. An application for a PD district shall specify the use or the combination of uses proposed, particularly if any of the proposed uses are not allowed by right in the base zoning district.
 - (2) Base district. In the PD district, uses shall conform to the standards and regulations of the base zoning district to which it is most similar. The particular base zoning district must be stated in the granting ordinance.
 - (3) Modifications. All applications to the City shall list all requested modifications/deviations from base standards set forth throughout the Development Code (applications without this list will be considered incomplete).
 - (4) Location. The location of all authorized uses shall be consistent with the PD master plan and the PD site plan.
 - (5) Residential uses. Residential dimensional and design standards shall be as set in the Development Standards Matrix.
 - (6) Density. Maximum density and minimum lot size are established in the Development Standards Matrix. Densities higher than those allowed within the base zoning district shall be tied to a public benefit, such as increased or improved open space, parkland, landscaping, amenities, etc. and be shown on the PD Master Plan.
 - (7) Drainage. Drainage features shall be integrated into the site design and comply with the City's Stormwater Drainage Design Manual; nature-based practices are encouraged where feasible.
 - c) Open space standards.
 - (1) Public or private. All Planned Development Districts (PDDs) shall be subject to the City's adopted Parkland Dedication requirements and Park Enrichment Fund contributions as

outlined in Chapter 10 of the Code of Ordinances. In addition to meeting Parkland Dedication requirements, each PDD must meet required on-site landscaping and open space criteria as specified in Article 14.05, which shall be privately maintained and managed by a Homeowners' Association or similar permanent agency.

1) Landscaping and open space requirements may be reduced if equal or better performance and public benefit is achieved through superior amenities, additional public parkland dedication and/or improvements, or the use of green infrastructure.

(2) Preservation of natural features. Unless otherwise provided by the PD ordinance or PD master plan:

- (a) Special Flood Hazard Areas shall be preserved and maintained as open space; and
- (b) Significant stands of native trees shall be preserved and protected from destruction or alteration pursuant to a tree preservation plan submitted to the City by the applicant.

(3) Open space allocation and preservation. Open space requirements shall be satisfied for each phase of a multiphase development. If open space is not to be provided proportionally, the applicant must execute a reservation of open space in a form that will ensure the City that such open space will be provided. The City may require that all open space within the PD district be provided prior to completion of development within the PD district. Parkland Dedication and any associated park improvements shall be included in the first phase of the development.

d) Height regulations. Unless otherwise provided by the PD ordinance, height regulations for uses shall be those established within the City's zoning regulations for the base zoning district.

e) Area regulations. Unless otherwise provided by the PD ordinance, area regulations for uses shall be those established within the City's zoning regulations for the base zoning district. The minimum allowable size for a PDD shall be five (5) acres.

(1) Small Site Exception: A PD may be established on a minimum site acreage of 1 acre for infill development or constrained sites if:

- (a) The PDD establishes superior outcomes compared to base zoning as far as design, open space, connectivity, or infrastructure, and;
- (b) Meets compatibility/transition and connectivity standards. City Council must find the PDD delivers equal or superior outcomes versus base zoning.

3) PD Master Plan

a) Mandatory. The PD master plan is a mandatory step in the creation of a PD district. It establishes general guidelines for the PD district by identifying the proposed land uses and intensities, building locations, building footprints, thoroughfare locations, and open space boundaries, including any

- proposed public trail systems. The PD master plan, as incorporated in the PD ordinance and together with the text of the ordinance, establishes the development standards for the PD district.
- b) Compliance with approved plans. Except as otherwise provided by the City's subdivision regulations, no development shall begin and no building permit shall be issued for any land within a PD district until a PD site plan that is substantially consistent with the PD master plan has been approved. Each PD district shall be developed, used, and maintained in compliance with the approved PD master plan, and subsequently conforming site plans, for the PD district, pursuant to the City's site development requirements within this Development Code.
 - c) Required Findings for Approval. Council may approve a PDD only if it finds:
 - (1) The PDD is in accordance with the Comprehensive Plan;
 - (2) The PDD will achieve equal or superior outcomes to base zoning for at least three of the following: site design, connectivity, open space, tree preservation, housing variety/attainability, infrastructure phasing, or environmental performance;
 - (3) Adequate public facilities will be available per adopted standards; and
 - (4) The PD Master Plan and Development Standards Matrix are clear and enforceable.
 - d) Establishment of District.
 - (1) Zoning amendment. The procedures for establishing a PD district shall be as for any other type of zoning request, except that more information is typically needed along with the request, and a master plan shall be submitted along with the request.
 - (2) Application. An application for the establishment of a PD district shall be submitted in accordance with this article. The application shall include:
 - (a) A PD master plan;
 - (b) A list of proposed PD district development standards;
 - (c) Identification of a zoning district, if any, which shall apply to the extent not otherwise provided by the PD master plan or by the proposed PD district development standards;
 - (d) A master plan informational statement; and
 - (e) A traffic impact analysis, as required or waived by the Director per the City's adopted TIA policy.
 - e) Governing regulations. Except to the extent provided by the PD master plan and the PD ordinance, development within the PD district shall be governed by all of the ordinances, rules, and regulations of the City in effect at the time of such development, including the standards of the zoning district identified in the application.
 - f) Conflict. Conflicts are governed by the order of control in Subsection g)(2).
 - g) PD master plan requirements.

- (1) Submission and Processing. A PD Master Plan and a Development Standards Matrix shall be submitted with the PD zoning application and reviewed by the Development Review Committee (DRC). If the PD is approved, both documents are adopted by reference and made part of the PD ordinance.
- (2) Development Standards and Order of Control. The Development Standards Matrix lists permitted/conditional uses and all modifications to base standards (e.g., modifications to base zoning standards; density/intensity; lot/building dimensions; setbacks/build-to; height; coverage/impervious; landscaping/buffers/tree preservation; lighting; screening/fencing; parking/loading; signage; open space/parkland; drainage/stormwater; utilities; street/alley cross-sections; block/lotting/connectivity; architectural/massing if applicable; and any phasing triggers or conditions). Accompanying graphics are illustrative unless expressly labeled "Regulatory." If a conflict exists, the PD ordinance controls, then the Development Standards Matrix, then any Regulatory graphics. Where the PD ordinance is silent, the referenced base district and this Code apply. The Director may waive submittal-format items for completeness (e.g., file type, sheet size, minor labels) but not substantive content; substantive changes require a PD amendment by City Council.
- (3) Information Statement (Non-Regulatory). A PD application shall include a brief narrative addressing:
 - 1) Consistency with the Comprehensive Plan;
 - 2) Total acreage;
 - 3) A conceptual phasing narrative (sequence of development and backbone improvements); and
 - 4) An aerial image delineating PD boundaries.
 - h) Master plan amendment.
 - (1) Major Amendment (rezoning required): any change that (i) adds a new use category or an increase in intensity of use; (ii) increases total dwelling units or nonresidential floor area by >10%; (iii) relocates a thoroughfare, removes a collector connection, or reduces block connectivity; (iv) reduces total open space by >10% or changes required park location/type; or (v) expands PD boundaries.
 - (2) Minor Modification (administrative—Director): adjustments to envelopes, lotting, or phasing that do not meet Major thresholds and maintain approval findings. The Director may refer a request to P&Z/Council.
- 4) Master Plan Adoption as Zoning Regulations. The PD Master Plan, including any regulating plan, development standards matrix, conditions of approval, and related exhibits approved with the Planned Development District (PDD) ordinance, is adopted as part of the zoning regulations applicable to the PDD.

- a) Continuation. The PD Master Plan shall remain in full force and effect concurrently with the PDD zoning district and shall govern the development and use of all property within the PDD unless and until the PD Master Plan or the PDD is amended, superseded, or repealed by ordinance in accordance with this Code.
- 5) Contents and format of master plan.
- a) Objective. Provide sufficient information for infrastructure planning and to demonstrate superior outcomes while allowing flexibility.
 - b) Scale. No smaller than 1" = 200'.
 - c) Contents.
 - (1) Boundary of the proposed area.
 - (2) A scaled drawing showing types and location of proposed uses.
 - (3) Thoroughfares and preliminary lot arrangements.
 - (4) A sketch drawing that shows the size, type and location of buildings and building sites, access, density, building height, fire lanes, screening, parking areas, landscaped areas, and project scheduling.
 - (5) Physical features of the site including a scaled drawing showing major existing vegetation, natural water courses, creeks or bodies of water and an analysis of planned changes in such natural features as a result of the development. This shall include a delineation of any flood prone areas.
 - (6) Any existing thoroughfares and easements.
 - (7) Location of proposed public open spaces.
 - (8) The points of ingress and egress from existing and proposed streets.
 - (9) A landscape plan showing turf areas, screening walls, ornamental planting, wooded areas to be preserved, and trees to be planted. The landscape plan should provide types of plantings to be used and give a general landscape design scheme for the development.
 - (10) A conceptual infrastructure plan showing the location of any existing or proposed utilities needed to adequately serve the development.
 - (11) Architectural drawings showing elevations and architectural style to be used throughout the development.
 - (12) A parks and trails plan showing any proposed parks, trails, hardscape, playscape, water feature or any other proposed improvements to any civic or open space.
 - (13) A Conceptual Drainage Plan as required by Appendix A of the City of Bastrop Stormwater Drainage Design Manual.
 - (14) Cover Sheet (title block, professionals, scales, north, date, gross/net acreage, legal description).

- (15) Vicinity Map (City/ETJ context and roadway network).
 - (16) Land Use Plan (use areas; residential ranges; nonresidential intensity; mixed-use areas; approximate units/lot counts by phase).
 - (17) Circulation Plan (thoroughfares/collectors; internal street/block framework; alleys if used; trails/sidewalks; access points; median openings/turn-lane concept and opposite-side coordination).
 - (18) A Preliminary Tree Survey as required by Article 14.06 and Tree Preservation Framework (preservation focus areas and construction-phase protection approach; detailed surveys due at land disturbance).
 - (19) Development Standards Matrix (Regulating Table).
- 1) The Development Standards Matrix shall include, at a minimum, the permitted and conditional uses, number of lots, density, minimum lot size, minimum lot width, maximum building height, building setbacks, parking/loading counts or parking ratios, maximum impervious cover, open space, usable open space, public parkland dedication, landscaping percentage or counts, signage, screening/fencing, block lengths, and architectural/massing if applicable.
- (20) Street & Edge Cross-Sections (Typicals). Internal sections and edge treatments/buffers along sensitive adjacencies.
 - (21) Phasing Plan (sequence of plats/site plans; backbone infrastructure; parks/open-space delivery; triggers for off-site improvements).
 - (22) Supporting Narrative (how the PDD implements the Comprehensive Plan and meets equal/superior outcomes; where base standards are replaced or supplemented).
 - (23) Impact Studies (as required) per City determination (TIA, utilities, environmental).
 - (24) Digital Submittals (PDF + GIS/CAD suitable for mapping adopted PD boundaries/land-use areas).
- 6) Submission and Review Process.
- a) Submission of complete application.
 - (1) For the purpose of this article, the “official submission date” shall be the date upon which a complete application for approval of a PD, that contains all elements and information required by this article, is first submitted to the Director. No application shall be deemed officially submitted until the Director determines that the application is administratively complete and a fee receipt is issued by the City.
 - (2) PD master plan applications that do not include all required information and materials will be considered incomplete, shall not be accepted for official submission by the Director, and shall not be scheduled on a P&Z agenda until the proper information is provided to City staff.

- 7) Additional Information. The City's staff may require information and data other than that set out in this section for specific PD master plans. This information may include but is not limited to: geologic information, water yields, flood data and hydrological studies, environmental information, traffic impact analysis, road capacities, market information, historic structure(s) and/or land, economic data for the proposed development. hours of operation, elevations and perspective drawings, lighting, and similar information. Approval of a PD may establish conditions for construction based upon such information.
- 8) Principles and standards for review.
- a) The following criteria have been set forth as a guide for evaluating the adequacy of proposed development within the City, and to ensure that all developments are, to the best extent possible, constructed according to the City's codes and ordinances.
 - b) The Director shall review the PD for compliance with all applicable City ordinances and with the Comprehensive Plan; for harmony with surrounding uses and with long-range plans for the future development of the City; for the promotion of the health, safety, order, efficiency, and economy of the City; and for the maintenance of property values and the general welfare.
 - c) PD review and evaluation by the Director shall be performed with respect to the following:
 - (a) The plan's compliance with all provisions of the zoning ordinance and other ordinances of the City.
 - (b) The impact of the development relating to the preservation of existing natural resources on the site and the impact on the natural resources of the surrounding properties and neighborhood.
 - (c) The relationship of the development to adjacent uses in terms of harmonious design, facade treatment, setbacks, building materials, maintenance of property values, and any possible negative impacts.
 - (d) The provision of a safe and efficient vehicular and pedestrian circulation system.
 - (e) The general design and location of off-street parking and loading facilities to ensure that all such spaces are usable and are safely and conveniently arranged.
 - (f) The sufficient width and suitable grade and location of streets designed to accommodate prospective traffic and to provide access for firefighting and emergency equipment to buildings.
 - (g) The coordination of streets so as to arrange a convenient system consistent with the transportation plan of the City.
 - (h) The use of landscaping and screening to provide adequate buffers to shield lights, noise, movement, or activities from adjacent properties when necessary, and to complement and integrate the design and location of buildings into the overall site design.

- (i) Exterior lighting to ensure safe movement and for security purposes, which shall be arranged so as to minimize glare and reflection upon adjacent properties.
 - (j) The location, size, accessibility, and configuration of open space areas to ensure that such areas are suitable for intended recreation and conservation uses.
 - (k) Protection and conservation of soils from erosion by wind or water or from excavation or grading.
 - (l) Protection and conservation of watercourses and areas subject to flooding.
 - (m) The adequacy of water, drainage, sewerage facilities, solid waste disposal, and other utilities necessary for essential services to residents and occupants.
 - (n) Consistency with the Comprehensive Plan.
- 9) Approval Process.
- a) Pre-application conference. The applicant(s) shall consult with the Director of Planning and Development and/or other designated administrative officers before preparing a PD Master Plan application in order to save time and money, and to avoid potential unnecessary delays.
 - b) Prior to formal application for approval of any PD, the applicant(s) shall request and attend a pre-application conference with the Director of Development Services, and any other pertinent City official(s) in order to become familiar with the City's development regulations and the development process.
 - c) City staff review. Upon official submission of a complete application for PD approval, the City shall commence technical review of the development proposal by forwarding a copy of the application to the Director of Planning and Development and the Development Review Committee (DRC). Development review team members shall review the application and shall ascertain its compliance with these and other applicable City regulations.
 - d) Supplementation and corrections. Following City staff review of the plan and supporting documents, discussions with the applicant on any revisions deemed advisable, and the kind and extent of improvements to be installed, the applicant shall resubmit additional copies of the corrected or supplemented plan to the Director within 60 calendar days following the date on which the applicant received official notification of the completion of the review by the DRC.
 - e) DRC Recommendation. Prior to consideration by the P&Z or City Council, all PD proposals must be reviewed by the DRC. The Director may forward a PD proposal to the P&Z and Council with or without a recommendation.
 - f) Action by P&Z/City Council.
 - (1) The P&Z shall review the PD application and shall recommend approval, approval subject to certain conditions, or disapproval of the PDD.

(2) The City Council shall consider the PD application at a public meeting following receipt of a determination by the P&Z. The City Council may also, where appropriate, remand the PD application back to the P&Z for reconsideration if it believes that there is a compelling reason to do so, such as the introduction of significant new facts or testimony.

10) Public hearing and notice.

- a) Hearings. The P&Z shall hold a public hearing and forward a recommendation to the City Council. The City Council shall hold a public hearing prior to adoption.
- b) Published and website notice (Council). Notice of the Council hearing must be published in the official newspaper and on the City website at least 15 days prior to the hearing.
- c) Mailed notice (P&Z). Mailed notice of the P&Z hearing shall be sent by regular mail to owners within 500 feet (City policy exceeding the state minimum 200 feet) at least 10 days prior to the hearing.
- d) Posted sign (home-rule). A zoning notice sign, at least 24"×48", shall be posted beginning not later than the 10th day before the P&Z hearing and remain until final Council action, consistent with LGC §211.0073. The applicant shall provide, install, and maintain the sign unless the City elects otherwise.
- e) Protests. Protests and voting thresholds shall follow LGC §211.0061. If a qualifying protest is filed, approval requires the vote specified by state law as amended.

11) Administrative fees. The City shall impose its standard fees for the negotiation, preparation and implementation of PDDs. These fees shall be established by the City Council in accordance with the City's fee schedule. The City may also recoup from applicants any out-of-pocket expenses related to professional services the City requires in order to design the PDD and related instruments. Third-party review costs (e.g., traffic, drainage, fiscal analysis) attributable to the application may be billed to the applicant.

12) Vesting. Vesting is determined under Local Government Code Chapter 245.

Sec. 14.02.004 Development Patterns.

A. Purpose. The City of Bastrop establishes optional development patterns to provide alternative methods of meeting the intent of the base zoning districts, to preserve significant natural features, and to create walkable, mixed-housing neighborhoods consistent with the Comprehensive Plan.

B. Applicability and Election.

1) Election at Time of Plat.

- a) A development pattern may be elected only in conjunction with a preliminary plat for the subject property. A site development plan may not establish, rescind, or change a development pattern.
- b) Final Plat Notation. If a development pattern is elected, the final plat shall include:

- (1) a note stating that the subdivision is subject to the elected development pattern in Sec. 14.02.004 and that all development within the platted area shall comply with those standards; and
 - (2) labels for all open space, parkland, and other tracts required by the elected pattern, with any limitations on use or further subdivision clearly noted.
 - 2) Binding Effect.
 - a) Upon recordation of a plat electing a development pattern, the elected pattern shall govern all subsequent development approvals, including site development plans, building permits, and replats, for lots within the platted area.
 - b) The City shall not approve any site development plan, building permit, or replat that would result in noncompliance with the elected pattern, unless the pattern is rescinded or modified through a replat or other plat amendment approved under the same level of review and public process as the original plat electing the pattern.
 - 3) Consistency of Site Development Plans. Any site development plan for property within a subdivision that has elected a development pattern shall demonstrate compliance with the applicable standards in this Section and with all notes, easements, and tract limitations shown on the recorded plat.
 - 4) Other Applicable Standards. Development using a pattern shall comply with all other applicable provisions of this Chapter, the Bastrop Code of Ordinances (including Chapter 10, Parks and Recreation), the City of Bastrop Drainage Manual, and all adopted technical criteria, except where a conflict is expressly resolved in favor of the development pattern standards.
- C. Clustered Land Development (CLD) Pattern.
- 1) Intent. The CLD pattern is intended to preserve significant natural features—such as creeks, floodplains, and mature tree stands—by clustering development onto smaller lots while providing permanent common open space.
 - 2) Where Allowed. The CLD Development Pattern is permitted in RR, SF-1, and SF-2 zoning districts.
 - 3) Minimum Site Area. A CLD shall consist of a minimum of twenty (20) acres of contiguous land under unified control at the time of plat approval.
 - 4) Open Space Requirements.
 - a) Minimum Open Space. At least forty percent (40%) of the gross site area shall be preserved as open space.
 - b) Relation to Parkland Dedication.
 - (1) Open space provided under this pattern shall be used to satisfy parkland dedication requirements as adopted by ordinance in Chapter 10 of the Bastrop Code of Ordinances. Open space intended to satisfy public parkland requirements shall be permanently dedicated to the City as Parks and Open Space in accordance with Chapter 10.

- (2) All public parkland tracts required under Chapter 10 and this Section shall be transferred to the City of Bastrop upon plat recordation, consistent with Chapter 10.
 - (3) Floodplains and/or drainage easements may only be included within the dedicated public parkland to the extent allowed by the Public Parkland Ordinance in Chapter 10.
 - (4) If the required forty percent (40%) open space exceeds the minimum public parkland dedication required by Chapter 10:
 - (a) The applicant may dedicate the additional open space to the City as public parkland, subject to City acceptance; or
 - (b) The additional open space may be set aside and permanently protected through an irrevocable conservation easement or other legal mechanism approved by the City Council and in a form acceptable to the City Attorney.
- 5) Lot Size and Dimensional Standards.
- a) Maximum Residential Density. The total number of dwelling units within a CLD shall not exceed the maximum residential density permitted by the underlying base zoning district.
 - b) Dimensional Requirements:
 - (1) Lot Size. Residential lot sizes may be reduced below the base district minimums where the CLD pattern is elected, so long as the CLD complies with the maximum residential density in subsection (A) and all applicable health, safety, and utility standards. The minimum lot area for each residential lot within a CLD shall be as shown on the approved plats.
 - (2) Lot Width. 40' minimum, unless otherwise shown on the approved plats.
 - (3) Setbacks and Building Separation. Setbacks may differ from the base zoning district standards and shall be as shown on the approved plat. In all cases, buildings shall maintain at least the minimum separation required by adopted building and fire codes.
 - (4) Building Height. Building height within a CLD shall not exceed the maximum height allowed in the underlying base zoning district.
 - (5) Maximum Impervious Coverage. The total impervious coverage for all lots and tracts within a CLD shall not exceed the maximum impervious coverage allowed by the underlying base zoning district.
 - (a) Individual lots may exceed the conventional lot-level impervious limits of the base district if the CLD, in the aggregate, remains at or below the district maximum and all stormwater, drainage, and water quality requirements are met, and a Master Final Drainage Plan is approved by the City for the development as a whole.
 - c) Connectivity and Access. Streets, blocks, and pedestrian facilities within a CLD shall comply with the City's access and connectivity standards in Article 14.04. CLD developments shall provide pedestrian connections to:

- (1) all required open space and public parkland; and
 - (2) existing or planned sidewalks, trails, or public streets in adjacent areas, to the maximum extent practicable.
- d) Ownership and Maintenance of Open Space. Open space not dedicated to and accepted by the City shall be:
- (1) owned and maintained by an HOA, condominium association, land trust, or similar entity with mandatory membership; or
 - (2) protected and maintained under a recorded conservation easement or similar instrument held by a land trust or other approved entity.
 - (3) Maintenance responsibilities for all non-City open space shall be set out in recorded covenants or similar documents, subject to City review for consistency with this Section before plat recordation.

D. Traditional Neighborhood Development (TND) Pattern.

1) *Reserved*

Sec. 14.02.005 Restrictions on Dwellings

- A. Applicability. The regulations set forth in this Section shall apply to all land, buildings and structures in any Zoning District that permits residential dwellings.
- B. Prohibited uses.
- 1) All uses not expressly permitted or authorized in the residential district by this article are prohibited. By way of example, but not in limitation, the following are prohibited:
 - a) Storage or accumulation within the public view of any salvage materials, discarded material, compost piles, lumber, waste products or scrap material, debris or junk;
 - b) Parking or storing any regulated vehicle except in a lawfully installed driveway;
 - c) Any use that constitutes a nuisance by reason of dust, noise, glare or other conditions that are offensive or detrimental to other property in a residential district or the occupants of that property;
 - d) The display within the public view of any products, materials, motor vehicles, equipment or other personal property for sale, lease, rent, trade, exchange or other disposition, except in connection with a garage or yard sale conducted by the resident of the home where such goods are displayed and provided that any such garage or yard sale is neither conducted for more than two consecutive days nor held more frequently than four times on any lot in any calendar year.
 - e) The display within the public view of any signs, except as permitted under the City's Sign Ordinance; and

- f) The rental of any residential amenity including, but not limited to, any feature of a residential dwelling, or place, except where the amenity is included as part of the rental of a dwelling for longer than 30 days.
- 2) Notwithstanding anything to the contrary within Sec. 14.02.008, the following are permitted uses in a residential zoning district:
- a) Storage of construction debris and construction materials generated or stored in connection with activity authorized by a valid building or demolition permit issued by the building official, subject to all regulations and restrictions applicable to the issuance of such permit; for the avoidance of doubt, upon the expiration, revocation, or suspension of a building permit, materials and debris must be removed from the property;
 - b) Parking or storing a regulated vehicle on a lawfully installed driveway.
 - c) Parking or storing a recreational vehicle on a lawfully installed driveway
 - d) Parking or storing a vehicle other than a regulated vehicle in any yard within public view, is permitted if the vehicle:
 - (1) Is on a lawfully installed driveway;
 - (2) Is operable; and
 - (3) Bears such indicia of a current and valid registration, inspection, and license as may be required by applicable law for operation or transport on a public street.
- 3) Definitions. The following words, terms and phrases, when used in this section, shall have the meanings ascribed to them in this subsection, except where the context clearly indicates a different meaning:

Recreational vehicle means a vehicular type unit primarily designed as temporary living quarters for recreational camping or travel use that either has its own mode of power or is mounted on or towed by another vehicle and is for personal use.

Regulated vehicle means any motor vehicle, camper, trailer, recreational vehicle, or boat, other than a conventional passenger vehicle, motorcycle, golf cart, or NEV.

Sec. 14.02.006 Contextual Neighborhood Setback Adjustment

- A. Contextual Neighborhood Setback Adjustment
 - 1) Applicability: Optional alternative to the base zoning district setback, applying to principal buildings fronting a local or collector street; applies to front setback and, on corner lots, the street-side setback.
 - 2) Measurement:
 - a) "Blockface" = all lots fronting the same street between intersecting streets.

- b) Use the two nearest developed lots on the same blockface to the left and the two nearest developed lots on the same blockface to the right of the subject lot to determine reference setbacks (wall plane only, excluding permitted encroachments).
 - c) If fewer than two developed lots exist on either the left or right side of the subject lot, use the next nearest developed lot(s) on the same blockface on that side until two developed lots are identified; establish the reference setback using the developed lots available on each side.
 - d) If fewer than four developed lots exist on the same blockface (two to the left and two to the right), the Director may use the nearest developed lots within 500 feet of the subject lot to establish the reference setback. If fewer than two developed lots are available within 500 feet, the base district setback applies.
- 3) Contextual Setback: simple average of reference setbacks, rounded to nearest whole foot. The DRC may allow ± 2 feet to align modules or avoid utilities.
 - 4) Limits: Does not authorize encroachments into visibility triangles, easements, drainage/flood setbacks, buffers, or critical root zones; permitted projections (porches, stoops, awnings) are measured from the contextual line per this Code.

Sec. 14.02.007 Highway Corridor Setbacks

- A. Purpose. The purpose of the Highway Corridor Setback is to reserve additional depth along state highway frontages under the jurisdiction of the Texas Department of Transportation (TxDOT) to accommodate potential future roadway expansion, utility relocation, and related public improvements, while allowing limited low-impact site features.
- B. Applicability.
 - 1) This section applies to all lots and tracts that have frontage on a roadway under TxDOT jurisdiction within the City limits and ETJ, except Chestnut Street, which is regulated by a separate corridor standard.
 - 2) The standards of this section apply in addition to the standards of the underlying zoning district and any applicable overlay district. Where conflicts occur, the more restrictive standard shall apply.
- C. Required Setback.
 - 1) A minimum 30-foot Highway Corridor Setback shall be provided from the property line that abuts a TxDOT right-of-way.
 - 2) The Highway Corridor Setback shall be measured perpendicular from the property line adjoining the TxDOT right-of-way along the full width of the lot frontage.
- D. Prohibited Improvements.

- 1) No permanent structure shall be erected or constructed within the required Highway Corridor Setback.
- 2) The following items are specifically prohibited within the required Highway Corridor Setback:
 - a) Permanent structures of any type with a fixed foundation
 - b) Buildings
 - c) Houses or dwelling units
 - d) Manufactured homes or HUD-code manufactured housing
 - e) Drainage detention or retention ponds or basins
 - f) Septic tanks or on-site wastewater disposal systems
 - g) Fuel or gas pumps and related pump islands
 - h) Underground storage tanks
 - i) Required off-street parking spaces and required accessible parking spaces
 - j) Vehicle charging stations
 - k) Required loading spaces
 - l) Any other site improvements that, in the opinion of the City Engineer or Building Official, would materially impede future roadway or right-of-way expansion.

E. Allowed Uses and Improvements.

- 1) The following uses and improvements may be located within the Highway Corridor Setback, subject to all other applicable standards of this Code:
 - a) Landscaping, irrigation systems, and open space
 - b) Monument, pole, or multi-tenant signs permitted by the Sign Regulations
 - c) Sidewalks, multi-use trails, and pedestrian amenities (benches, furnishings)
 - d) Driveway connections, access drives, and turn lanes approved by the City and TxDOT
 - e) Public or private utilities and utility easements, excluding prohibited tanks and septic systems listed in subsection D
 - f) Stormwater conveyance features (e.g., swales, ditches, inlets, and piping) that do not function as detention or retention basins
 - g) Overflow or surplus parking spaces that are not counted toward the minimum off-street parking requirement and that can be readily removed or reconfigured in the future

- h) Fences, walls, and screening that can be removed or relocated without substantial structural demolition.
 - 2) The City may require an applicant to demonstrate, as part of site plan review, that any improvements proposed within the Highway Corridor Setback can be reasonably removed or modified in the event of future TxDOT right-of-way acquisition or roadway widening.
- F. Plat and Site Plan Notation. All subdivision plats and site development plans for property subject to this section shall clearly show and label the “Highway Corridor Setback – 30 feet” along the TxDOT frontage, and shall note the restrictions on permanent structures within the setback.

Sec. 14.02.008 Table of Permitted Uses.

- A. Purpose. The Table of Permitted Uses establishes the allowed land uses within each zoning district. The table provides a clear and predictable framework for property owners, developers, and the public by identifying which uses are permitted by right, which require additional review, and which are prohibited. This section is intended to ensure compatibility between land uses, protect community character, and promote orderly growth consistent with the City’s Comprehensive Plan.
- B. Legend.
 - P = Permitted by right
 - C = Conditional Use (requires Planning and Zoning Commission and City Council approval)
 - NP = Not Permitted
- C. District Abbreviations. SF = SF-1, SF-2, and SF-3.
- D. Table of Permitted Uses.

Primary Residential Uses

Use	P/OS	RR	SF	MU	GC	PI	IND
Single-Family Dwelling Detached	NP	P	P	P	NP	NP	NP
Single-Family Dwelling Attached (Townhome)	NP	NP	NP	P	NP	NP	NP
Duplex	NP	P	C	P	NP	NP	NP
Multiple-Family Dwelling (Apartment)	NP	NP	NP	P	C	NP	NP
Patio Home / Zero Lot Line	NP	NP	NP	P	NP	NP	NP
Manufactured Homes	NP	P	C	NP	NP	NP	NP

Modular Home	NP	P	P	P	NP	NP	NP
Barndominium	NP	P	C	C	NP	NP	NP
Bed and Breakfast	NP	C	C	P	C	NP	NP
Hotel/Motel	NP	NP	NP	C	P	NP	C
Manufactured Home Park	NP	C	NP	NP	NP	NP	NP
Live/Work Unit	NP	NP	NP	P	C	NP	NP
Community Home	P	P	C	P	C	P	NP
Boarding / Rooming House	NP	NP	C	P	C	NP	NP
Housing for Elderly/Senior	NP	NP	C	P	C	NP	NP
Recreational Vehicles (RV's)	NP	NP	NP	NP	NP	NP	NP

Accessory & Incidental Uses

Use	P/OS	RR	SF	MU	GC	PI	IND
Accessory Structure—Residential (Accessory to a Residential Use)	NP	P	P	P	NP	NP	NP
Accessory Structure—Nonresidential (Accessory to a Commercial Use)	P	P	NP	P	P	P	P
Accessory Dwelling Units	NP	P*	P*	P*	NP	NP	NP
Swimming Pool (Private)	P	P	P	P	C	P	C
Tennis Court / Recreation	P	P	C	C	C	P	NP
Off-Street Parking (Incidental)	P	P	P	P	P	P	P
EV Charging Stations	P	P	P	P	P	P	P
Data Storage Buildings (As an Accessory to a Primary Commercial Use)	NP	C	NP	NP	P	P	P

*Subject to Section 14.04.006.

Utility, Service & Other Uses

Use	P/OS	RR	SF	MU	GC	PI	IND
Electrical Substation	C	C	C	C	C	P	P
Water Reservoir / Pump	NP	C	NP	NP	NP	P	P
Utility Shop / Storage	C	C	C	C	C	P	P
Public Buildings (Municipal, Fire, Police)	P	NP	NP	NP	C	P	NP
Wireless Telecommunication Facilities	NP	P	NP	NP	NP	NP	P
Utility, Minor (lift station, pump, small substation)	P	P	P	C	C	P	P
Utility, Major (treatment plants, large substations)	C	C	NP	NP	C	P	P
Solar Farm/Battery Energy Storage Systems (BESS)	C	P	NP	NP	NP	NP	P
Wind Energy Conversion System (WECS)	C	P	NP	NP	NP	NP	P

Recreational & Entertainment Uses

Use	P/OS	RR	SF	MU	GC	PI	IND
Park / Playground	P	P	P	P	C	P	NP
Private Clubs / Country Clubs	NP	C	NP	C	C	NP	NP
Golf Course (Commercial)	P	C	C	C	C	C	NP
Amusement / Recreation (Indoor/Outdoor)	P	C	NP	NP	C	P	C
RV Park/Campground	NP	C	NP	NP	NP	NP	NP
Indoor Entertainment (arcade, bowling, trampoline, etc.)	NP	NP	NP	C	P	C	NP
Outdoor Entertainment (amphitheater, sports complex, etc.)	P	C	NP	C	P	C	NP
Theater/Cinema (fixed seats)	NP	NP	NP	P	P	C	NP

Educational, Institutional & Special Uses

Use	P/OS	RR	SF	MU	GC	PI	IND
School / Nursery / Childcare	NP	P	P	P	P	P	NP
Church / Temple / Rectory	NP	C	C	P	P	C	NP
Community Center (Public)	P	NP	NP	NP	C	P	NP
Hospital / Assisted Living / Skilled Nursing	NP	NP	NP	C	P	P	P
College / University	NP	NP	NP	NP	C	P	C
Library/Museum	NP	NP	NP	C	P	P	NP
Social Service Facility (food bank, counseling), Shelter/Transitional Housing	NP	C	NP	C	P	P	NP
Cemetery (human burial)	NP	C	NP	NP	C	P	C
Crematorium (human or animal)	NP	P	NP	NP	C	P	P

Transportation & Auto-Related Uses

Use	P/OS	RR	SF	MU	GC	PI	IND
Parking Lot / Structure	P	NP	NP	C	P	P	P
Automobile Repair	NP	C	NP	C	P	NP	P
Automobile Sales	NP	C	NP	C	P	NP	P
Auto Parts Store (Retail)	NP	C	NP	C	P	NP	P
Motor Freight / Hauling	NP	C	NP	NP	C	NP	P
Heliport / Airport	NP	C	NP	NP	C	P	P

Office & Professional Uses

Use	P/OS	RR	SF	MU	GC	PI	IND
General Offices	NP	NP	NP	P	P	C	P
Medical / Dental / Labs	NP	NP	NP	P	P	NP	P
Banks / Financial Institutions	NP	NP	NP	P	P	NP	C
Telemarketing / Call Centers	NP	NP	NP	C	P	NP	P

Retail & Service Uses

Use	P/OS	RR	SF	MU	GC	PI	IND
Retail Shops (General)	NP	NP	NP	P	P	NP	C
Restaurants / Cafeterias	NP	NP	NP	P	P	NP	C
Food Trucks (As a Primary Use)	NP	NP	NP	P	P	NP	NP
Gas / Fuel Sales	NP	NP	NP	C	P	NP	P
Personal Services (Salon, Tailor, etc.)	NP	NP	NP	P	P	NP	C
Animal Services / Vet	NP	C	NP	C	P	NP	C
Bar/Lounge/Nightclub	NP	NP	NP	C	P	NP	NP
Event Venue/Banquet Hall/Reception Facility	NP	NP	NP	C	P	C	C
Food Truck Park	NP	C	NP	C	P	NP	NP
Convenience Store (with fuel)	NP	NP	NP	C	P	NP	P
Convenience Store (without fuel)	NP	NP	NP	P	P	NP	C

Car Wash	NP	C	NP	C	P	NP	P
Vehicle Renting/Leasing	NP	NP	NP	C	P	NP	P
Towing/Vehicle Storage Lot (impound)	NP	C	NP	NP	C	NP	P
Outdoor Sales & Display (garden center/lumberyard)	NP	C	NP	C	P	NP	P
Tattoo/Body Art Studio	NP	NP	NP	C	P	NP	C
Pawn Shop	NP	NP	NP	C	C	NP	C
Liquor Store	NP	NP	NP	C	P	NP	C

Commercial / Industrial Use

Use	P/OS	RR	SF	MU	GC	PI	IND
Light Manufacturing	NP	C	NP	NP	C	NP	P
Heavy Manufacturing / Industrial	NP	NP	NP	NP	NP	NP	P
Warehousing / Distribution	NP	NP	NP	NP	C	NP	P
Breweries / Distilleries	NP	NP	NP	C	P	NP	P
Wineries	NP	NP	NP	C	P	NP	P
Outdoor Storage / Equipment	NP	C	NP	NP	C	NP	P
Commercial Kennel	NP	C	NP	C	C	NP	P
Self-Service Storage	NP	NP	NP	C	P	NP	P
Contractor Shop (with outdoor yard)	NP	C	NP	NP	C	NP	P

Contractor Shop (without outdoor yard)	NP	C	NP	C	P	NP	P
Artisan Manufacturing/Makerspace (small-scale production)	NP	C	NP	P	P	NP	P
Data Center/Research & Development Lab	NP	NP	NP	NP	C	NP	P
Recycling Facility (collection)	NP	C	NP	C	P	NP	P
Materials Recovery Facility (processing)	NP	NP	NP	NP	NP	NP	C
Salvage Yard/Junkyard (heavy)	NP	NP	NP	NP	NP	NP	C
Concrete/Asphalt Batch Plant (heavy)	NP	NP	NP	NP	NP	NP	C
Fuel/Chemical Bulk Storage (heavy)	NP	NP	NP	NP	NP	NP	C
Smoke/Vape Shops	NP	NP	NP	NP	C	NP	P
Sexually Oriented Buildings (SOB's)	NP	NP	NP	NP	NP	NP	P

ARTICLE 14.03 SPECIAL DISTRICTS AND OVERLAYS

Sec. 14.03.001 District 1832

- A. Purpose. District 1832 preserves and strengthens Bastrop’s historic central area, including the traditional street grid neighborhoods and the community’s downtown commercial and mixed use centers, by supporting walkable, small-scale development, active street fronts, and context-sensitive infill. District 1832 balances reinvestment and flexibility with the protection of established residential character and the historic block-and-street framework.
- B. Applicability. The standards of the underlying zoning district shall apply, except as modified herein.
- C. Boundaries. The District 1832 overlay boundaries are shown on the Official Zoning Map adopted as Reference A, which is incorporated by reference and maintained on file with the City Secretary and Development Services Department.
- D. Standards.
 - 1) Single-Family Districts.
 - a) Prohibited rezonings. No property within District 1832 may be rezoned to SF-2 or SF-3.
 - b) Build-to zone. A front build-to zone of 15–25 feet is required; eligible adjustments for infill development may be approved per Article 14.02.05 (Contextual Neighborhood Setback Adjustment).
 - c) Limited commercial by Conditional Use. Any use typically permitted in a Mixed-Use district may be considered as a Conditional Use on Single Family Zoned Lots within District 1832.
 - (1) Process. Conditional Use Permits (CUPs) shall follow the procedures in the Administration & Procedures Article, plus a recommendation from the Main Street Advisory Board to the City Council when the property is within the Main Street Program jurisdiction (Downtown Bastrop District). After Main Street Advisory Board and the Planning and Zoning Commission provide a recommendation, the application shall be forwarded to the City Council for decision.
 - (2) Conditions. City Council may impose conditions to address parking, hours, screening, landscaping, signage, deliveries, or other operational/site impacts.
 - (3) Residential character. Approved commercial activity shall be wholly contained within the residential structure and shall maintain the residential scale and character on the street.
 - 2) Mixed Use Districts.
 - a) The minimum lot size for the Mixed-Use Zoning District with District 1832 is 1/3 of an acre. Mixed Use Lots that are currently less than 1/3 acre may continue to be developed and utilized, but may not be further subdivided.
 - b) Build-To-Zone: 10–15 feet.

- (1) Contextual option. Eligible adjustments to match prevailing block-face setbacks may be approved per Article 14.02.05 (Contextual Neighborhood Setback Adjustment).
- 3) Uses in the District 1832 Overlay.
 - a) Residential over nonresidential. In Commercial or Mixed-Use districts, upper-story residential is permitted by-right over ground-floor retail/office throughout District 1832, provided 1 off-street space per bedroom is supplied (unless otherwise approved through an adopted shared-parking or demand-management process).
 - b) Conditional Uses. The following uses, when otherwise permitted by-right, are Conditional Uses within District 1832:
 - (1) Tattoo studios
 - (2) Drive-through facilities
 - (3) Automotive repair or sales
 - (4) Fueling stations
 - c) Prohibited Uses:
 - (1) Smoke/vape shops
 - (2) Sexually Oriented Businesses (SOB's)
- 4) Historic Block Preservation.
 - a) Purpose. Maintain the historic small-block grid that the core of Bastrop was built on—approximately 330 × 330 feet—to carry forward downtown walkability and connectivity.
 - (1) Right-of-way vacations. The vacation or abandonment of any public street or alley within District 1832 is prohibited unless the City Council determines that equal or better public connectivity will be provided through a new public street/alley or a recorded public access easement of equivalent function.

Sec. 14.03.002 Downtown Bastrop

- A. Purpose. The Downtown Bastrop District is established to: (1) define the geographic area served by the City's Main Street Program, as recognized by the Texas Historical Commission in 2007; (2) reinforce the traditional, pedestrian-oriented character and economic vitality of Downtown; and (3) implement district-specific development standards consistent with the design standards recommended by the Historic Landmark Commission and the Main Street Advisory Board.
- B. Applicability. The standards of the underlying zoning district and the 1832 Overlay apply to all property within the Downtown Bastrop District, except as modified herein. Where the provisions of the Downtown Bastrop District conflict with the underlying zoning district or the 1832 Overlay, the more restrictive standard shall apply.

- C. Boundaries. The boundaries of Downtown Bastrop District are shown on the map adopted as Reference A on Official Zoning Map, which is incorporated by reference and maintained on file with the City Secretary and Development Services Department.
- D. Conditional Use Permits. For any Conditional Use Permit (CUP) within the Downtown Bastrop District, the applicant shall obtain a recommendation from the Main Street Advisory Board (to the City Council) in addition to following standard CUP procedures in this Code. After a recommendation from Main Street Advisory Board and the Planning and Zoning Commission, the application shall be forwarded to the City Council. Conditions may be applied to any CUP to ensure compatibility with the purpose of the Downtown Bastrop District and the adopted Main Street design standards.
- E. Signs: For properties within the Downtown Bastrop District, the Director of Planning and Zoning, upon favorable recommendation of the Main Street Director, may administratively approve a sign that deviates from Sign Code numeric/material limits (design, size, height, number of signs, etc.) when compatible with downtown character. Electronic message centers/digital displays, flashing, or moving signs are prohibited.
- F. Chestnut Street Corridor. Applies to any lot fronting Chestnut Street within the Downtown Bastrop District.
 - 1) Build-to zone. 10–15 feet.
 - 2) Parking location. No parking between the primary façade and the Chestnut right-of-way. Any parking visible from a public street must be screened per the Landscaping Article.
 - 3) Landscaping. The Landscaping Article (Article 14.05) applies, including frontage and parking-lot landscaping. No credits, waivers, or alternative compliance may reduce required frontage landscaping or parking-lot screening on Chestnut within the Downtown Bastrop District.
- G. Building Size and Format. Maximum ground-floor footprint. Buildings in General Commercial or Mixed-Use districts shall have a maximum ground-floor building footprint of 5,000 sq. ft.
 - 1) Exception—Larger Footprint. The City Council may grant an exception to subsection 6(a) to allow a ground-floor building footprint exceeding 5,000 sq. ft., upon a favorable recommendation from the Main Street Advisory Board and the Planning & Zoning Commission, and per the procedures in the Administration & Procedures Article. Approval requires findings that:
 - a) the building is multi-tenant;
 - b) the street-facing façade provides public entrances at intervals of at least every 75 feet;
 - c) the massing is articulated into distinguishable bays consistent with downtown storefront rhythms;
and
 - d) the project maintains pedestrian orientation and block-scale consistent with District 1832.

H. Design Guidelines

- 1) Appendix D contains the Downtown Bastrop District Design Guidelines, as recommended by the Main Street Advisory Board. Use of the Design Guidelines is voluntary; however, applicants are strongly encouraged to incorporate them to ensure compatibility with the established character of Downtown Bastrop. The Main Street Advisory Board and Main Street staff may provide nonbinding façade and design guidance upon request.

Sec. 14.03.003 Downtown Historic District.

- A. Purpose. This district was certified as part of the National Register of Historic Places by the National Park Service on December 22, 1978, and is subject to the Historic Preservation Ordinance in Article 14.09. The purpose of this district is to preserve the architectural and cultural integrity of Bastrop's historic downtown commercial corridor while allowing for compatible economic development.
- B. Applicability.
 - 1) The underlying zoning district applies except as modified by this section and the Historic Preservation Ordinance.
 - 2) All development, alterations, and demolitions are subject to review and approval in accordance with the Historic Preservation Ordinance and must obtain a Certificate of Appropriateness.
- C. Boundaries. The boundaries of Downtown Historic District are shown on the Official Zoning Map adopted as Reference A, which is incorporated by reference and maintained on file with the City Secretary and Development Services Department.
- D. Standards.
 - 1) Maximum Building Height: 35 feet (not including parapets up to 4 feet that screen rooftop equipment).
 - 2) Minimum lot size and minimum lot width: None.
 - 3) Build-To-Line: 0-5 feet from the front property line.
 - 4) Building Frontage at Build-To-Line: 80% minimum of the lot's primary street frontage.
 - 5) Side and Rear Setbacks: None (subject to Building/Fire Code).
 - 6) Parking Minimums: No minimum off-street parking. Exception: residential uses must provide 1 space per dwelling unit. Removal of any existing off-street parking spaces is not permitted unless approved by the DRC and the Main Street Director.
 - 7) Parking Placement: No parking in the front or side yard; access from alleys where available.
 - 8) Sidewalks: Maintain a continuous, ADA-compliant clear pedestrian zone of at least 8 feet along the frontage. Where existing conditions preclude 8 feet, the Main Street Director may allow the maximum feasible clear width, but not less than 6 feet.

- a) Sidewalk encroachments: Public furnishings/patio furniture (tables, benches, chairs, benches, etc.) may be permitted upon approval of the Main Street Director if at least 4 feet of ADA compliant sidewalk is maintained.
- 9) Landscaping: Article 14.05, Landscaping Requirements, does not apply in the Downtown Historic Overlay. However, parking lot screening must be provided in accordance with Article 14.05 where parking is visible from the frontage. Frontage trees are required at an average spacing of 30 feet on center where feasible. Spacing adjustments may be administratively approved at 20-40 feet where constraints exist per Article 14.05. If a tree would block a storefront or similar unique constraint exists, the Planning Director and Main Street Director may approve an alternative or waiver.
- 10) Ground-Floor Transparency: For new or redevelopment, between 2 and 10 feet above sidewalk grade, a minimum 70% of the street-facing façade shall be clear, non-reflective glazing. Existing facades should be preserved unless approved through a Certificate of Occupancy.
- 11) Lighting: On street and exterior attached lighting shall be consistent with the Historic Landmark Commissions adopted Design Guidelines

ARTICLE 14.04 DEVELOPMENT STANDARDS

Sec. 14.04.001 Site Design

- A. Refuse and Recycling Facilities (Dumpsters, Compactors, Service Areas).
- 1) Applicability. This subsection applies to all nonresidential development and all multifamily development utilizing centralized refuse service.
 - 2) Location.
 - a) Refuse and recycling facilities shall be located in the side or rear yard.
 - b) Facilities are prohibited within a required front yard unless the Director determines there is no feasible alternative due to documented site constraints.
 - c) Facilities shall not block sidewalks, accessible routes, drive aisles, fire lanes, required parking, or required pedestrian circulation.
 - d) Facilities shall be sited to minimize visibility from public streets and to minimize impacts on adjacent residential districts, including odor, noise, and visual impacts.
 - 3) Screening and Enclosure Standards.
 - a) Dumpsters and compactors shall be fully screened by a permanent enclosure.
 - b) Height. Enclosure walls shall be at least six (6) feet in height and at least one (1) foot higher than the top of the dumpster or compactor lid, unless a greater height is needed to fully screen equipment.
 - c) Materials. Enclosures shall be constructed of durable materials compatible with the principal building, including masonry, architectural metal panels, or wood with masonry columns. Chain-link with slats is prohibited as primary screening.
 - d) Gates. Gates shall be opaque and maintained in operable condition. Gates shall be closed when not in active use.
 - e) Pad. Enclosures shall be located on a paved pad with positive drainage.
 - 4) Truck Access and Maneuvering.
 - a) Adequate access and maneuvering for collection vehicles shall be provided.
 - b) The site plan shall demonstrate collection vehicle access by turning templates or other documentation acceptable to the City Engineer when requested.

- c) Collection routes should minimize backing movements and avoid conflicts with primary pedestrian routes where feasible.

B. Vision Clearance (Sight Triangles).

1) When Required.

- a) At intersections of public streets.
- b) At driveway intersections with a public street.
- c) At internal street intersections where required by the City Engineer.

2) Dimensions. Sight Visibility Requirements.

- a) Assumptions: At-grade intersection with approaches of 3.0 or, 3.5-foot driver eye height above pavement; both drivers can see each other.

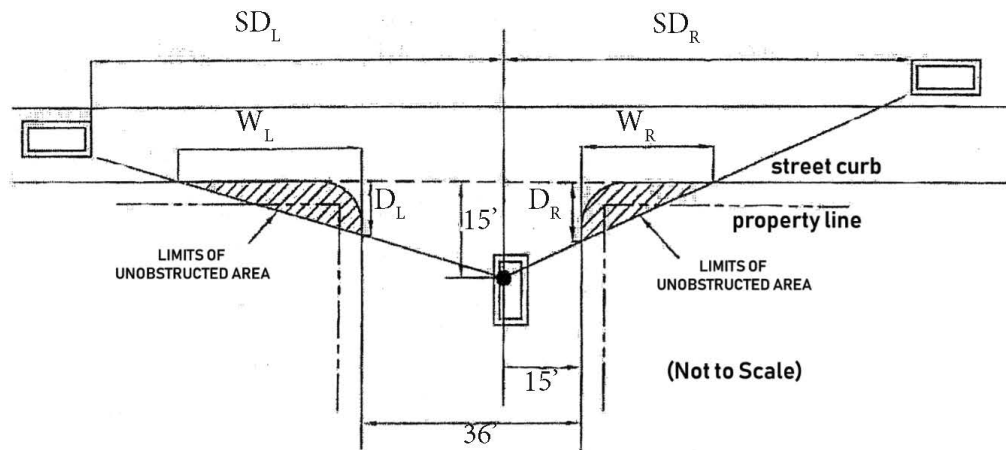

Speed Limit	Minimum Sight Distance		90-Degree Intersections			
	SDL	SDR	WL	WR	DL	DR
20	180	190	89	80	13	13
25	245	255	128	111	13	14
30	315	325	210	120	13	14
35	390	400	270	165	14	14
40	480	545	330	210	14	14
45	580	650	400	260	14	14
50	585	655	400	260	14	14

- b) SDL and SDR are the required sight distance, in feet, to the left and to the right as measured from the driver's eye on the controlled intersection approach looking towards oncoming cross traffic.
- c) WL and WR are the distance, in feet, along the curb line of the side of the visibility triangle parallel to the path of traffic on the uncontrolled intersection approach.
- d) DL and DR are the distance, in feet, along the curb line of the side of the visibility triangle parallel to the path of the driver on the controlled intersection approach.
- e) The distances given for WL, WR, DL, and DR are applicable to 90-degree intersections only.

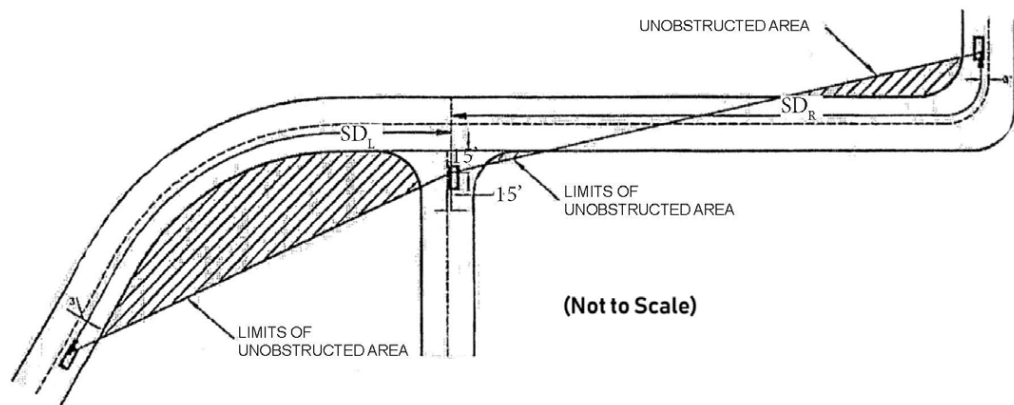

3) Obstructions Prohibited.

- a) Within a required sight triangle, no structure, fence, wall, sign, landscaping, berm, or other obstruction shall be placed or maintained between thirty (30) inches and eight (8) feet above the adjacent roadway grade.
- b) Trees may be permitted if limbed up and maintained to preserve sight lines.

C. Encroachments Into Required Setbacks (Porches, Decks, Stairs).

1) General. Encroachments are permitted as stated below provided they:

- a) Do not encroach into recorded easements.
- b) Do not obstruct required sight triangles.
- c) Comply with applicable building and fire codes.

2) Allowed Encroachments.

- a) Unenclosed porches, stoops, and covered entries may encroach into the required front setback by up to five (5) feet, but shall not be closer than ten (10) feet to the front property line.

- b) Stairs, steps, and landings serving a primary entrance may encroach into the required front setback by up to ten (10) feet, but shall not be closer than five (5) feet to the front property line.
- c) Unenclosed decks and patios may encroach into required rear and interior side setbacks by up to five (5) feet, but shall not be closer than three (3) feet to the property line.
- d) Unenclosed porches, stoops, and covered entries serving a rear entrance may encroach into the required rear setback by up to ten (10) feet, but shall not be closer than ten (10) feet to the rear property line.
- e) Stairs, steps, and landings serving a rear entrance may encroach into the required rear setback by up to fifteen (15) feet, but shall not be closer than five (5) feet to the rear property line.
- f) Accessibility ramps may encroach as necessary to meet accessibility requirements, subject to Director approval, provided they do not obstruct required pedestrian circulation.

D. Fences and Walls.

- 1) Applicability. All fences and walls shall comply with this Section unless superseded by an overlay district or an approved PDD development plan.
- 2) Height and Transparency.
 - a) Front yard.
 - (1) Maximum height: fifty-four inches (54”).
 - (2) Transparency: at least fifty (50) percent open area.
 - b) Side and rear yards.
 - (1) Maximum height: six (6) feet.
 - (2) On corner lots, fences in the street side yard between the front property line and the front building line shall comply with the front yard standard.
 - c) Sight triangles. Fences and walls shall not obstruct required sight triangles.
- 3) Maintenance. Fences and walls shall be maintained upright and in good repair.

E. Number of Primary Structures Per Lot.

- 1) General Rule. Unless expressly allowed by the applicable zoning district or an approved development plan, no more than one (1) primary structure shall be permitted on a platted lot.
- 2) Exceptions. Multiple primary structures may be permitted when:

- a) The zoning district permits commercial, multifamily, mixed-use, campus-style nonresidential, or similar development types commonly arranged as multiple buildings;
 - b) A PDD; or
 - c) The approved plan demonstrates compliance with applicable setbacks, access, parking, fire access, utilities, and all other development standards.
- 3) Accessory Structures. Accessory structures allowed under Section 14.04.005 (Accessory Uses and Structures) do not count as primary structures.

Sec. 14.04.002 Sidewalks and Pedestrian Connectivity Standards.

A. Purpose and Intent.

- 1) Ensure safe, accessible pedestrian routes along street frontages that connect development to the broader network.
- 2) Implement the City’s adopted Transportation Master Plan (TMP) and Comprehensive Plan by requiring context-sensitive sidewalks or shared-use paths.
- 3) Provide limited, staff-approved alternatives or fee-in-lieu when immediate construction is unnecessary or better deployed to priority sidewalk projects.

B. Applicability.

- 1) When Required. Sidewalks are required at the time of the site development plan along all public and private street frontages for:
 - a) New Construction
 - b) Additions that increase gross floor area by $\geq 50\%$ or impervious cover by $\geq 25\%$;
 - c) Change of use that intensifies site activity (as determined by the Director)
 - d) Sidewalks are required along entire perimeter of subject property where adjacent to any public or private ROW.
- 2) Relationship to Subdivision Code. Chapter 10 of the Code of Ordinances (Subdivisions) may impose additional or earlier sidewalk installation; compliance with both chapters is required.

C. Definitions.

- 1) Clear Width (Through-Zone). The unobstructed portion of sidewalk reserved for pedestrian travel.
- 2) Fee-in-Lieu. A payment accepted by the City in place of constructing a required sidewalk, deposited into the Sidewalk Fund.
- 3) Shared-Use Path (Sidepath). A paved, 8–10 ft path intended for pedestrians and bicyclists, typically parallel to a roadway or along a greenway.
- 4) TMP. The City’s adopted Transportation Master Plan, including functional class maps and typical sections.

5) Director. The Director of Development Services or designee.

D. Design, Width, and Placement.

- 1) ADA/TAS. All sidewalks and ramps shall comply with ADA and Texas Accessibility Standards, including cross-slope, longitudinal slope, surfaces, turning areas, and passing space requirements. A ramp shall be provided anywhere a sidewalk terminates.
- 2) Minimum Sidewalk Width. The minimum clear width for each frontage is based on the street’s TMP functional class verified at site plan. In the event the TMP conflicts with this chart, the TMP shall override these requirements.

TMP Functional Class	Frontage Context	Minimum Sidewalk (each side)
Local	Neighborhood / residential streets	5 ft
Collector	Neighborhood connectors / commercial collectors	5 ft
Minor Arterial	Commercial corridors	6 ft
Principal Arterial	Major corridors / state routes (coordinate with TxDOT)	6 ft – 8 ft
Local (Downtown Context)	Main Street / Downtown Core	8 ft

- a) If back-of-curb (no planting strip), increase minimum by +1 ft;
 - b) Maintain 80-inch vertical clearance and keep the through-zone free of obstructions;
 - c) Sidewalks must extend to property lines to enable future connections.
 - d) Where tying into existing sidewalk network, the Director may determine the appropriate width to maintain consistency with existing infrastructure and future plans.
- 3) Alignment and Easements. To avoid utilities, mature trees, or grade constraints, sidewalks may meander if the clear width is maintained and the walk is within ROW or a public sidewalk easement granted to the City.
 - 4) Intersections & Ramps. Provide ADA-compliant curb ramps and detectable warnings at all corners and mid-block crossings serving the site.

E. Shared-Use Path Alternative

- 1) If the TMP, Trails/Sidewalk Plan, or corridor plan designates a shared-use sidepath along the frontage, the applicant shall construct a 10-ft path (8-ft if constrained) in lieu of standard sidewalks, with connections to public sidewalks and site entrances.
- 2) City-Directed Substitution. The City Engineer or Development Director may require a sidepath in place of standard sidewalks on corridors identified for multi-modal function or safety.

F. Construction, Timing, and Materials.

- 1) Timing. Required sidewalks/paths shall be constructed prior to Certificate of Occupancy unless a deferral or fee-in-lieu is approved under this Section.
 - 2) Standards. Sidewalks shall be concrete or other similar hard surface, per City detail/specifications. Decorative pavers may be approved if ADA compliant and maintained by the developer.
- G. Fee-in-Lieu of Sidewalk Construction.
- 1) A fee-in-lieu may be approved by the Director when all of the following are found:
 - a) Immediate construction would not provide a functional connection (e.g., isolated segment, no near-term tie-in), or the City determines funds are better used on a higher-priority sidewalk project within the service area; and
 - b) The frontage is not scheduled for City/TxDOT sidewalk within the next 5 year capital program window; and
 - c) No school zone, transit stop, park, or civic generator within a distance that would make the sidewalk critical to near-term pedestrian safety, as determined by the Director or City Engineer.
 - 2) The fee is published in the Master Fee Schedule and updated as needed to reflect the full cost to construct the required infrastructure.
 - 3) Sidewalk Fund. Fees are deposited in a dedicated Sidewalk Fund and may be expended only for sidewalks, curb ramps, or shared-use paths—preferably within the same district or vicinity to maximize nexus.
- H. Maintenance and Obstructions.
- 1) The adjacent property owner shall maintain the sidewalk in safe condition (debris, vegetation, snow/ice where applicable) and repair hazards caused by their improvements or use.
 - 2) The required clear width must remain unobstructed. Street furniture, signage, planters, and café seating must be outside the through-zone and permitted where applicable.
 - 3) Sidewalk grade and material shall carry across driveway aprons to prioritize pedestrian continuity.
- I. Easements and Right-of-Way
- 1) If adequate right-of-way does not exist to place the required sidewalk, the applicant shall dedicate a public sidewalk easement or additional right-of-way as determined by the City.
- J. Enforcement
- 1) Condition of Approval. Sidewalk obligations (build or fee-in-lieu) are conditions of site plan/building permit approval and prerequisites to CO.
- K. Coordination with Other Agencies.
- 1) TxDOT Frontages. Improvements along state facilities must meet this Section to the extent practicable and be coordinated with TxDOT. Where TxDOT standards conflict, the Director and City Engineering Department may adjust details while maintaining the minimum clear width and ADA compliance.
 - 2) Utilities/Franchise. Coordinate placement to avoid conflicts and preserve required clear width.
- L. Plan Integration.

- 1) Site plans shall demonstrate consistency with the TMP functional class, Thoroughfare Plan, and any adopted Sidewalk/Trails Plans.
- 2) Where a plan (Comprehensive Plan, Parks and Recreation Masterplan, Transportation Master Plan, etc.) calls for enhanced streetscape or greater pedestrian capacity, the City may require widths exceeding the table in subsection D, in accordance with the adopted guiding document.

Sec. 14.04.003 Outdoor Lighting

- A. Purpose and Intent. Standards of this section are intended to provide adequate Lumen output to safely light sidewalks, streets, public places, and private properties. Dark skies are a key part of Bastrop’s authentic nature. The Lighting Standards promote a future dark sky for the community.
- B. Scope. This Section applies within the City Limits.
 - 1) Nothing herein shall be construed as preventing or limiting the City from applying this Section to the ETJ through agreements with property owners, or as a term affixed to a conditional approval.
- C. Exemptions. The following are exempt from the application of the standards of this section:
 - 1) Lighting equipment required by law to be installed on motor vehicles; or
 - 2) Lighting required for the safe take-off and landing of aircrafts.
- D. Prohibition. A person commits an offense by doing the following:
 - 1) Installs outdoor lighting contrary to this section.
 - 2) Fails to comply with any terms or conditions set forth in a permit issued under this section.
 - 3) Installs outdoor lighting without obtaining a permit when the total number of lumen outputs for all lights installed within any 90-day period is greater than 2,500 lumens.
- E. New Lighting
 - 1) General. All Outdoor Lighting shall be installed in conformance with the provisions of this Section, applicable electrical codes, energy codes, and Building Codes, except as provided herein.
 - 2) Nonresidential. All Outdoor Lighting installed on Nonresidential properties shall conform to the Standards by this Section, except as provided herein.
 - 3) Residential. All Outdoor Lighting installed on Residential properties that is affixed to a Construction Project that a building permit is required under this Code shall conform to the Standards established by this Section.
- F. Nonconforming Existing Lighting
 - 1) All existing Outdoor Lighting that was legally installed before the enactment of this Section which does not conform with the Standards specified imposed by this Section shall be considered nonconforming. Nonconforming Outdoor Lighting is allowed to remain until required to be replaced pursuant to the terms of this Section.
 - 2) If more than 50% of the total appraised value of a Structure (as determined from the records of the Bastrop Central Appraisal District), has been destroyed, the nonconforming status expires and the

Structure's previously nonconforming Outdoor Lighting must be removed and may only be replaced in conformity with the Standards of this Section.

- 3) Nonconforming Outdoor Lighting shall be brought into conformance with this Section as follows:
 - a) Nonresidential Application. All existing Outdoor Lighting located on a subject property that is part of an Application, Subdivision approval, or a building permit for a major Addition is required to be brought into conformance with this Article before final inspections, issuance of Certificate of Occupancy, or Final Plat recordation, when applicable. For the following permits issued by the City, the Applicant shall have a maximum of 90 days from the date of permit issuance to bring the Lighting into conformance: Site Development permit, Sign permit for an externally or internally illuminated outdoor Sign, initial alcoholic beverage permit, initial food establishment permit, and on-site sewage facility permit.
 - b) Residential Addition or remodel. Nothing herein shall be construed to terminate a Residential property's nonconforming status as a result of an Addition or remodel.
 - c) Abandonment of nonconforming. A nonconforming Structure shall be deemed abandoned if the Structure remains vacant for a continuous period of 6 months. In that instance, the nonconforming status expires and the Structure's previously nonconforming Outdoor Lighting must be removed and may only be replaced in conformity with the Standards of this Section.
- 4) It is unlawful to expand, repair or replace Outdoor Lighting that was previously nonconforming, but for which the prior nonconforming status has expired, been forfeited, or otherwise abandoned.
- 5) Outdoor Lighting on property used for Commercial purposes that is not in conformance with this Section shall be brought into conformance with this Section within 10 years from the date of the adoption of this Section. For property annexed into the City Limits after the date of the adoption of this Section, the 10-year period established by this Subsection shall commence upon the effective date of the annexation. Nothing in this Subsection may be construed to allow Light Trespass or any other form of nuisance from Outdoor Lighting. A new purchaser of property may request a three-year extension to come into compliance if property is purchased within 10 years of the enactment of this Section.

G. Shielding and Total Outdoor Light Output Standards.

- 1) City owned streetlights, if rated by the B-U-G classification system:
 - a) Shall be rated and installed with the maximum backlight component limited to the values in Table 1 based on location of the light fixture where the property line is considered 5 feet beyond the actual property line.

Table 1	Governmental Owned Rating
Fixture is greater than 2 mounting heights from property line	B3
Fixture is 1 to less than 2 mounting heights from property line	B2
Fixture is -.5 to 1 mounting heights from property line	B1
Fixture is less than 0.5 mounting height to property line	BO

- b) Shall be rated and installed with the upright component of zero (U0); and
 - c) Shall be rated and installed with the glare component of no more than G1 unless four-sided external shielding is provided so that the Luminous Elements of the fixture are not visible from any other property. Mounting height or topography may cause the Luminous Elements of a G1 or G0 rated governmental owned street light to require additional shielding to reduce glare.
- 2) Governmental owned streetlights, if not rated by the B-U- G classification system, shall meet the qualifications to be full cutoff fixtures. (See Figure A). Mounting height or topography may cause the Luminous Elements of a governmental owned streetlight to require additional shielding to reduce glare.

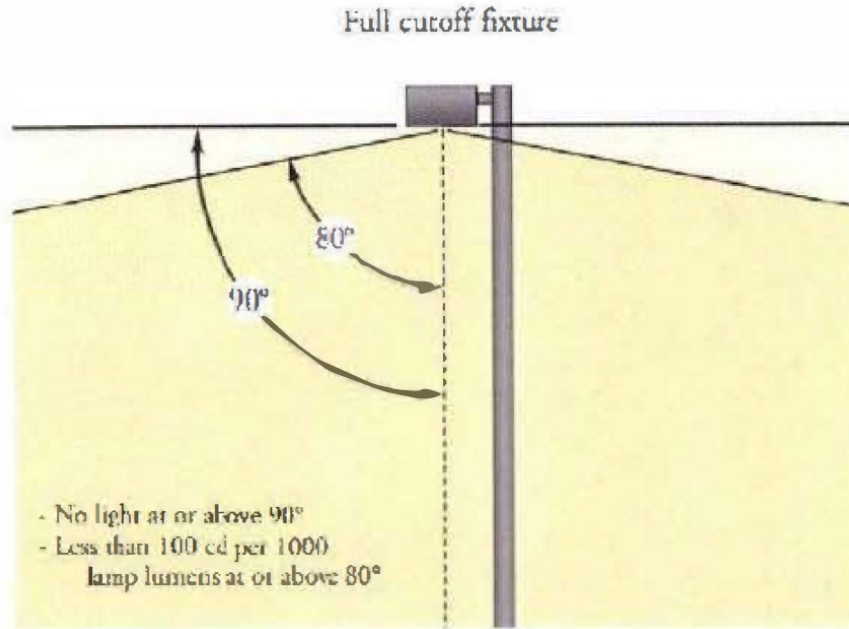
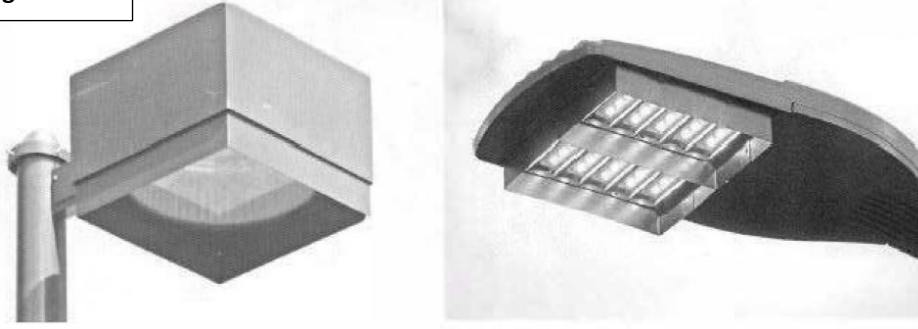

Figure A: Full cutoff fixtures do not allow any light to be emitted above the fixture. The fixture limits the light output in the first 10 degrees below the horizontal, to less than 10% of the total light output.

- 3) All Outdoor Lighting, except governmental owned streetlights, shall be shielded so that the Luminous Elements of the fixture are not visible from any other property. Mounting height or proximity to property lines may cause the Luminous Elements of a light fixture to require additional shielding (See Figure B and Figure C).

Figure B



Unacceptable / Do Not Use

Fixtures that produce glare and light trespass

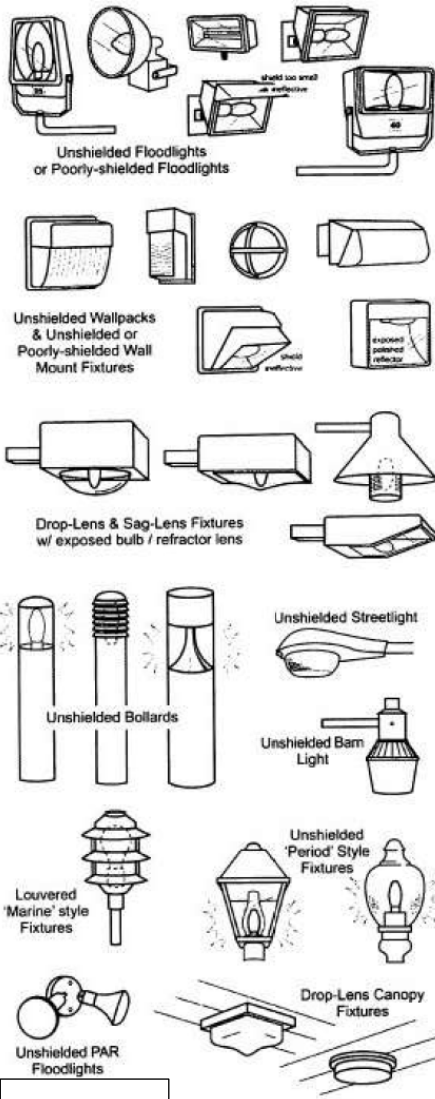

Figure C

Usually Acceptable / May Need Shielding

Fixtures that shield the light source to minimize glare and light trespass and to facilitate better vision at night



- 4) Nongovernmental light fixtures, if rated by the B-U-G classification system:
 - a) Shall be rated and installed with the maximum backlight component limited to the values in Table 1 based on location of the light fixture where the property line is considered to be 5 feet beyond the actual property line;
 - b) Shall be rated and installed with the uplight components of zero (U0), except for Uplighting covered in this Section;
 - c) Shall be rated and installed with the glare component no more than G0 unless four-sided external shielding is provided so that the Luminous Elements of the fixture are not visible from any other property; and
 - d) Shall be shielded in accordance with this Section.
- 5) Outdoor Uplighting is prohibited, except in cases where the fixture is shielded by a roof overhang or similar structural shield and a licensed architect or engineer has stamped a prepared Lighting plan that ensures that the light fixtures(s) will not cause light to extend beyond the structural shield, and except as specifically permitted in this article.
- 6) Outdoor Lighting fixtures, except Uplighting are not allowed to have light escape above a horizontal plane running through the lowest point of the luminous elements. (See Figure D and Figure E).

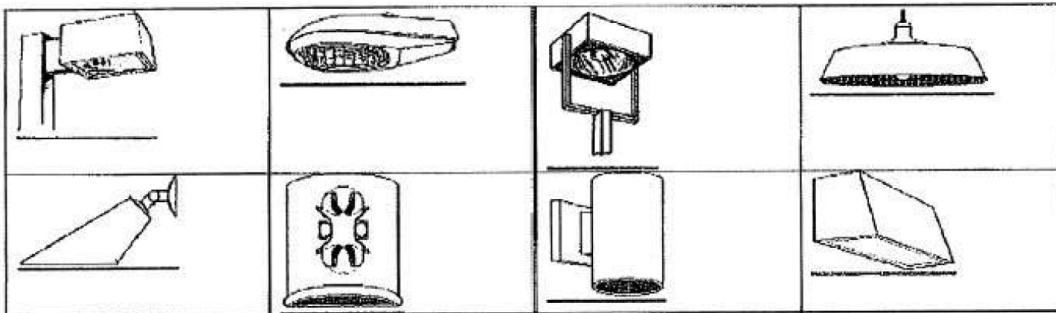

Figure D: This figure shows examples of fixtures that may conform to the provision to not allow light to escape above a horizontal plane running through the lowest point of the Luminous Elements if they are closed on top and mounted such that the bottom opening is horizontal. Note that the mounting height and proximity to the property line, or internal optics may cause them to need additional shielding to prevent the Luminous Elements from being visible from any other property.

A practical way to determine if a light fixture will conform to the provision to not allow light to escape above a horizontal plane running through the lowest point of the luminous elements: the lamp or tube, any reflective surface or lens cover (clear or prismatic) must not be visible when viewed from above or the side.

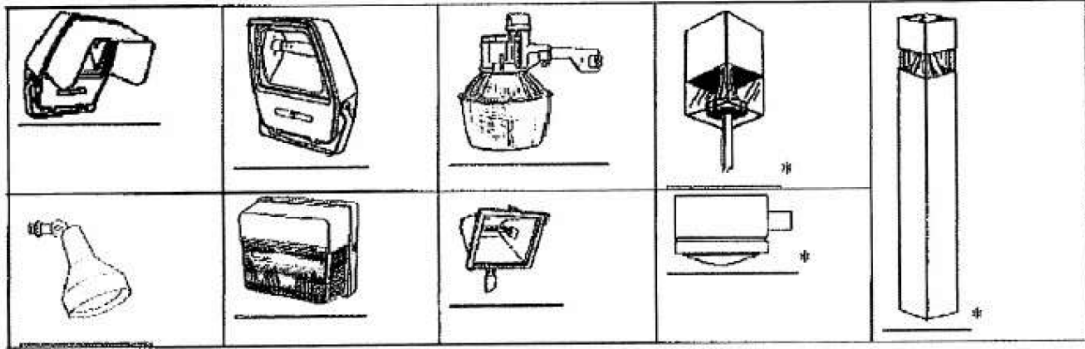

Figure E: This figure illustrates examples of fixtures that do not conform to the provision to not allow light to escape above a horizontal plane running through the lowest point of the luminous elements.

**Note: Even though the lamps in these fixtures are shielded from direct view when viewed from the side or above, reflective surfaces within the fixtures and/or lens covers are directly visible from the side.*

- 7) Total Outdoor Light Output (excluding governmental owned streetlights used for illumination of public rights- of-way and outdoor recreation facilities) of any Nonresidential property shall not exceed 100,000 lumens per net acre in any contiguous illuminated area. This Lumen per net acre value is an upper limit and not a design goal; design goals should be the lowest levels that meet the requirement of the task.
- 8) Total Outdoor Light Output (excluding governmental owned streetlights used for illumination of public rights- of-way and outdoor recreation facilities) of any Residential property shall not exceed 25,000 lumens per net acre in any contiguous illuminated area.

H. Outdoor Recreation Facilities

- 1) Lumen cap exemption.
 - a) Outdoor recreational facilities are not subject to the lumens per net acre limit.
 - b) Outdoor Lighting for sports facilities shall be designed to create minimum off-site spill, glare, and sky glow while honoring the guidelines for class IV play, as defined by the Illuminating Engineering Society of North America (IESNA) publication, IES RP-06 or guidelines of a recognized sports organization such as the Texas University Interscholastic League (UIL), Little League, or the United States Soccer League. To be considered a recognized sports organization, the City must first approve such organizations guidelines.
 - c) Class IV levels of illumination, as defined by IESNA, are encouraged to be utilized during practices if the competition Lighting is established at a higher illumination level than class IV.
 - d) Shielding. Fixtures used for non-aerial sports, such as track and field, shall be fully shielded. Fixtures used for aerial sports, such as baseball and softball shall be shielded to the full extent possible while also allowing the minimum of vertical illuminance needed by the players to track the ball as stated in writing by a sports Lighting engineer recognized by peers as being an expert in that field. The

sports Lighting vendor must meet the guidelines for the specific sport and have the lowest available off-site spill, glare, and sky glow values.

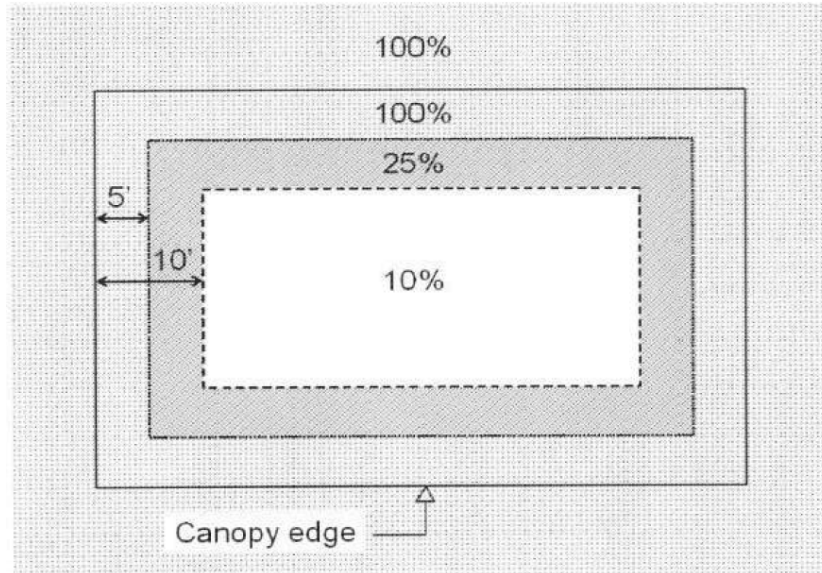

Figure E: Plan view of a canopy, showing fixture location and initial lamp output percentage counted toward total lumens.

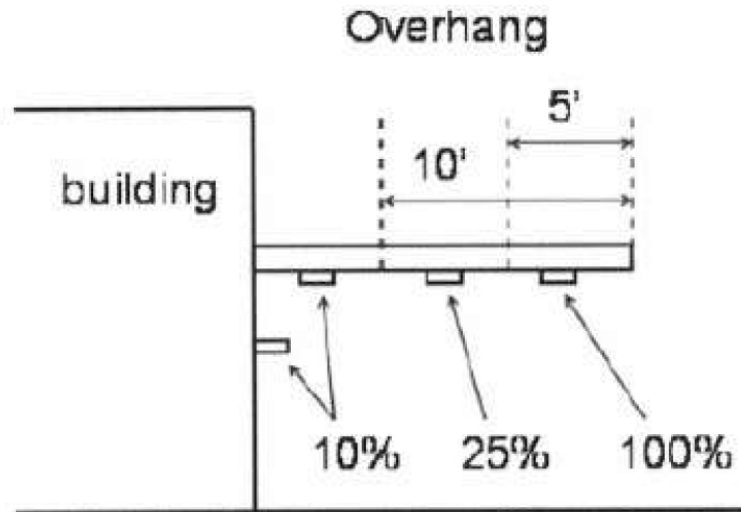

Figure G.

- 2) Certification. Lighting systems for outdoor recreational facilities shall be designed and certified by an engineer registered in the state as conforming to all applicable restrictions of this Code before Construction commences. Further, after installation is complete, an engineer registered in the state shall certify that the Lighting system installation is consistent with the certified design.

- 3) Curfew. No sports facility shall be illuminated between 10:30 p.m. and sunrise, except as necessary to conclude a scheduled recreational or sporting event already in progress that began before 9:30 p.m., or for lighting located under canopies, building overhangs, or roof eaves.
- 4) All outdoor light fixtures located under canopies, under Building overhangs, or under roof eaves must conform to all provisions of this article.
- 5) Outdoor light fixtures located under canopies, under Building overhangs, or under roof eaves where the center of the lamp or luminaire is located at 5 feet, but less than 10 feet from the nearest edge of the canopy or overhang are to be included in the Total Outdoor Light Output as though they produced only $\frac{1}{4}$ of the lamp's rated Lumen output (See Figure F and Figure G).

I. Neon Lighting

- 1) Neon Lighting is permitted, so long as Lumen calculations from such Lighting are included in the Total Outdoor Light Output calculations for the Site . Lumens are calculated on a per foot basis, rather than per "fixture." Such Lighting shall also be subject to the shielding requirements of this section, unless exempted under the Exemptions Subsection of this Section.



Figure H.

J. Flagpoles

- 1) If the flag of the United States of America is displayed during the hours of darkness, it should be illuminated as recommended in the Federal Flag Code.
- 2) Lighting of up to a total of 2 flags per property is permitted with the following conditions:
 - a) The flags must either be the flag of the United States of America, a flag of the state, a flag of a military branch of the United States of America or a flag of a branch of military of the state in order for illumination to be permitted.
 - b) Flagpoles with a height greater than 20 feet above ground level shall be illuminated from above, if illuminated at all. This may be achieved by utilizing a light fixture attached to the top of the flagpole

or a fixture mounted above the top of the flagpole on a Structure within 15 feet of the flagpole and must comply with all sections of this article except for lights such as the ones in Figure K. The total number of lumens initially output from any light fixture mounted on top of or above a flagpole is limited to 800.

- c) Flagpoles with a height equal to or less than 20 feet above ground level may be illuminated from below. They are to be illuminated with up to 2 spot type fixtures utilizing shields or diffusers to reduce glare, whose maximum combined Lumen output is 78 lumens per foot of pole height, measured from the light fixture to the top of the flagpole. The fixture is to be mounted so that the lens is perpendicular to the flagpole and the light output points straight up at the flag.
- d) Lamps used for flagpole illumination shall be included in the Total Outdoor Light Output.

K. Lighting Curfews

- 1) Nonresidential Outdoor Lighting intended to be left on more than 30 minutes after closing or the completion of activities must be reduced to 25% or less of the Total Outdoor Light Output allowed.
- 2) Motion sensor activation may be allowed to cause the light to resume Total Outdoor Light Output allowed only when activated and to be reduced back to 25% or less of Total Outdoor Light Output allowed within 5 minutes after activation has ceased, and the light shall not be triggered by activity off the property.
- 3) The 75% reduction in illumination may be accomplished by dimming, by turning off 75% of the light fixtures, by a combination of the two, or by any other method that results in a Total Outdoor Light Output of no more than 25% of the Total Outdoor Light Output allowed.
- 4) Illumination for all advertising Signs, both externally and internally illuminated, shall be turned off by the later of closing time or 10:00 p.m., provided, however, that such Signs may be turned back on prior to sunrise, but no more than one hour prior to opening.
- 5) Street Lighting, other than at the intersection of roadways, shall utilize half night photocells or timers to turn off the lights halfway between dusk and dawn. Passive reflective roadway markings are encouraged.
- 6) Outdoor recreational facilities must follow the curfew as defined in the Shielding and Total Outdoor Light Output Standards Section of this Section.
- 7) All Outdoor Lighting is encouraged to be turned off when no one is present to use the light.

L. Prohibitions

- 1) The installation of any mercury vapor fixture or lamp for use as Outdoor Lighting is prohibited.
- 2) Luminaries rated at more than 3000 Kelvin (K) are prohibited with the exception of luminaries installed prior to the enactment of this revised article rated no more than 4000K, that are shielded on every side so that the source of light is not visible from any other property and the combination of all such fixtures within any ten-foot by ten-foot area does not produce more than 4100 lumens for a pole mounted fixture or 2050 lumens for a wall mounted fixture. Luminaries with a higher Kelvin rating are permitted if the Scotopic-to-Photopic (S/P) ratio is no greater than 1.2.

- 3) The installation of any barn-light style fixture for use as Outdoor Lighting is prohibited unless the fixture includes a full opaque reflector instead of the standard translucent lens. An example of barn-light style with and without the required opaque reflector is shown in Figure L.
- 4) The operation of searchlights for advertising purposes is prohibited.



Figure L: Acceptable shielding of barn-style light fixtures.

M. Submission of Plans and Evidence of Compliance

- 1) All building permit applications must include an Outdoor Lighting plan that includes the following information:
 - a) The location of all existing and proposed light fixtures (may be included on-Site Plan).
 - b) A Lumen calculation sheet to determine lumens per net acre. It must include the square footage of the total area to be illuminated, the light fixture catalog descriptions or ordering number, lamp types (i.e., incandescent, low pressure sodium, compact fluorescent, LED, etc.), the Kelvin rating for the lamp, the B-U-G rating for the selected fixture (if available); the number of fixtures or lamps (use the same unit corresponding to the unit used to determine how many lumens are produced), fixture or lamp initial lumens, the location from the edge of a canopy (if applicable), and mounting height of all existing and proposed lamps.
 - c) Manufacturer's specification sheets for all existing and proposed light fixtures.
 - d) Elevations with notes where light fixtures are to be installed indoors that may be seen from the exterior.
 - e) Site plan with specific measurements in feet for the area to be illuminated. A scale notation is not sufficient.
 - f) Acknowledgement that the Applicant has received notification of the provisions of this Section.
- 2) Upon receipt of Residential building permit applications, City staff shall provide the homebuilder and/or Applicant with educational materials about this article. The City's submission of educational materials shall be prima facie evidence that the Applicant has received notification of the provisions of this Section.

- 3) Verification that a Residential or Commercial Construction Project requiring a building permit Application has complied with the provisions of this article shall occur during the final electrical inspection by the City building inspector.
 - 4) For the first 60 days after the enactment of this article, Residential building permit Applicants may postpone the submission of the plans and evidence of compliance defined in this section for a maximum of 30 business days after the submission of their building permit Application.
- N. Exemptions. The following Lighting instances are exempt from this article:
- 1) Outdoor light fixtures with a maximum output of 180 lumens per fixture, regardless of the number of bulbs, may be left unshielded provided the fixture has a diffuser installed, and the source of the light is not visible from any other property. The output from these fixtures shall not exceed 10% of the Total Outdoor Light Output allowed.
 - 2) Outdoor light fixtures with a maximum output of 360 lumens per fixture, regardless of the number of bulbs, that are shielded with a medium to dark tone lens provided said lens reduces the Lumen output approximately in half, and the source of the light is not visible from any other property. The output from these fixtures shall not exceed 10% of the Total Outdoor Light Output allowed.
 - 3) Outdoor Lighting that light is produced directly by the combustion of fossil fuels.
 - 4) Lighting required by law to be installed on motor vehicles.
 - 5) Lighting needed during activities of law enforcement, fire and other emergency services.
 - 6) Lighting employed during emergency repairs of roads and utilities may be unshielded provided the lights are positioned so they do not shine in the eyes of passing drivers.
 - 7) Lighting required for the safe operation of aircraft.
 - 8) Temporary Lighting required to save life or property from imminent peril provided the lights are positioned so they do not shine in the eyes of passing drivers.
 - 9) Festoon type low-output lamps are limited to small individual bulbs on a string with a maximum output of 56 lumens within any square foot. The bulbs must have a rating of no more than 2800 Kelvin, may not be located within 3 feet of a reflective surface such as a light colored or metal wall, and the bulbs may not be visible from any Residential property within 50 feet of the installed lights. The Lumen output from these lamps shall be doubled for inclusion in the Total Outdoor Light Output calculations and that doubled Lumen value shall not exceed 20% of the Total Outdoor Light Output allowed for the property.
 - 10) Low-intensity mini-lights or rope-type lights in amber, gold, yellow, cream, red, orange, or warm white wrapped on a tree, post, or other similar object provided the layers are at least 6 inches apart. The output from these mini-lights shall not exceed 2% of the Total Outdoor Light Output allowed for the property and will be included in the lumens calculation for the Total Outdoor Light Output allowed.
 - 11) Temporary Lighting for theatrical, television, performance areas, events, or Construction areas provided the lights are positioned so they do not shine in the eyes of passing drivers and the source of the

illumination is shielded from any other property. This Temporary Lighting must not allow any light to be projected or reflect above the Structures or trees on the property.

12) Lighting required by federal or state laws or Standards.

Sec. 14.04.004 Off-Street Parking, Loading, and Bicycle Parking Standards.

A. Purpose. The purpose of this section is to ensure that adequate and appropriately designed off-street parking, loading, and bicycle facilities are provided for all land uses, while avoiding excessive impervious cover and encouraging multimodal transportation. These standards are intended to:

- 1) Balance the needs of residents, businesses, and visitors.
- 2) Reduce traffic congestion and hazards from on-street parking.
- 3) Protect adjacent neighborhoods from spillover impacts.
- 4) Provide flexibility through shared parking and demand-based studies.
- 5) Encourage sustainable practices, including bicycle use and electric vehicle readiness.

B. Applicability.

- 1) Off-street parking, loading, and bicycle parking shall be provided in accordance with this ordinance for all new development, redevelopment, and changes of use.
- 2) If a use is not listed, the Planning Director shall determine the most similar use or require a parking demand study.

C. Definitions.

- 1) Cross-Access Easement. A recorded easement allowing vehicles and pedestrians to travel between adjoining sites so that driveways/parking areas connect, as required by this Code.
- 2) Drive Aisle. An internal maneuvering lane that provides access to parking spaces and loading areas and is not a through street.
- 3) Drive-Through Stacking Space. A queued vehicle position in a drive-through lane, exclusive of the service window/box, meeting the minimum dimensions and counts in this Article.
- 4) ITE (Institute of Transportation Engineers). A professional association whose Parking Generation Manual (latest edition) and related database provide empirically derived parking demand rates/equations by land-use code (e.g., GFA, units, employees). Commonly used to estimate peak-period parking demand for stand-alone uses; data skews suburban and should be adjusted for local/contextual factors.
- 5) Loading Space (Berth). A designated area for the standing, loading, and unloading of trucks, meeting the dimensional, clearance, screening, and location standards of this Article.
- 6) Off-Street Parking. A paved, striped area on private property (outside the public right-of-way) intended for the parking of motor vehicles, required and regulated by this Article.

- 7) **Parking Demand Study (PDS).** Means a report prepared by a qualified professional engineer or transportation planner that estimates on-site parking demand for a proposed or existing use using accepted sources, field observation, and calibrated assumptions.
- 8) **Parking Space (Standard).** A striped stall meeting the dimensional and design standards of this Article.
- 9) **Remote/Off-Site Parking.** Required parking located on a separate parcel or tract within an approved walking distance and secured by a legal agreement.
- 10) **Reserve (Banked) Spaces.** Means spaces identified on a plan but not initially constructed and only installed if monitored demand meets defined triggers.
- 11) **Shared Parking.** Means the practice of satisfying the parking demand of multiple land uses with a common supply recognizing different peak periods and internal capture.
- 12) **Transportation Demand Management (TDM).** Means strategies that reduce single-occupant vehicle trips and parking demand (e.g., unbundled parking, transit benefits, carpool/vanpool, bike facilities).
- 13) **ULI (Urban Land Institute).** A research organization whose Shared Parking (latest edition) methodology models mixed-use parking demand by applying time-of-day/day-of-week factors, internal capture, mode split, pricing, and seasonal adjustments to determine combined peak occupancy and right-sized supply.

D. Minimum Off-Street Parking Requirements.

- 1) **Minimum Size:**
 - a) **Residential:** 10' x 20' stall sizes or equivalent sq. footage in slanted stalls, and parked vehicles may not block sidewalks.
 - b) **Commercial:** 9' x 18' stall sizes or equivalent sq. footage in slanted stalls.
- 2) **Residential Uses:**
 - a) **Single-Family / Two-Family Dwelling:** 1 space per bedroom
 - b) **Townhouse / Multifamily:** 1 space per bedroom
 - c) **Accessory Dwelling Unit (ADU):** 1 space per bedroom.
- 3) **Nonresidential and Mixed Uses**

Use Category	Minimum Off-Street Parking Requirement
Retail, personal service, general commercial	1 space per 250 sq. ft. GFA
Restaurant, bar, café	1 space per 100 sq. ft. GFA
Office, professional services	1 space per 400 sq. ft. GFA
Medical / Dental office or clinic	1 space per 250 sq. ft. GFA
Hospital	1 space per 400 sq. ft. or 1 space per 2 beds

Hotel / Motel	1 space per guest room
Religious institution	1 space per 275 sq. ft.
Schools (K-12)	1 space per 500 sq. ft. GFA
College / Higher education	1 space per 400 sq. ft. GFA
Childcare / Daycare	1 space per 350 sq. ft. GFA, plus a designated drop-off/pick-up area
Fitness center, gym, indoor recreation	1 space per 200 sq. ft. GFA
Entertainment (theater, bowling, skating, arcade, etc.)	1 space per 250 sq. ft. GFA
Civic uses (library, museum, government building)	1 space per 300 sq. ft. GFA
Parks / outdoor recreation facilities	As determined by the Planning Director or Parks and Recreation Director, based on use intensity (fields, courts, trailhead, etc.)
Assembly, theater, auditorium	1 space per 40 sq. ft. assembly area or 1 space per 4 fixed seats.
Industrial, warehouse, wholesale	1 space per 1,000 sq. ft. GFA; 1 per 300 sq. ft. for office/showrooms.
Self-storage	1 space per 20 storage units (minimum 3)
Civic uses (library, museum, government building)	1 space per 300 sq. ft. GFA
Furniture, mattress, appliance, or similar large item retail with accessory warehouse/storage (warehouse showroom)	1 space per 400 sq. ft. of public showroom/sales floor area (GFA), plus 1 space per 1,000 sq. ft. of non-public warehouse/storage area (GFA). Office area shall be parked at 1 space per 300 sq. ft. where separately identified.

E. Maximum Parking. Any request to exceed 125% of the minimum required off-street parking shall require approval by the Development Review Committee. The DRC may impose conditions reasonably related to mitigating impacts, including but not limited to requiring a professionally prepared parking demand study, enhanced parking-lot landscaping or tree canopy, designation of deferred “reserve” spaces, and/or shared-parking.

F. Flexibility and Alternative Compliance

1) Parking Demand Study

- a) An applicant may submit a professionally prepared parking demand study (using ITE, ULI, or other accepted methodology).

- b) The DRC may approve reduced parking if the study demonstrates that the proposed supply will adequately serve the use.
- 2) Shared Parking
 - a) Developments with multiple uses may share parking if peak hours do not overlap.
 - b) A reduction of up to 50% of the total required spaces may be approved with a shared parking agreement.
- 3) Remote / Off-Site Parking
 - a) Off-site parking is permitted if within 500 feet walking distance of the entrance to the building and secured by legal agreement.

G. Bicycle Parking

- 1) Applicability. Required for all nonresidential and multifamily developments.
- 2) Minimums.
 - a) Multifamily: 1 long-term space per 5 units.
 - b) Nonresidential: 1 short-term space per 20 required vehicle spaces (minimum 2).
- 3) Design.
 - a) Bicycle racks must be securely anchored, ADA accessible, and located within 50 feet of main entrances.

H. Loading and Stacking

- 1) Loading Spaces
 - a) 1 space per 20,000 sq. ft. GFA of commercial, office, or industrial use.
 - b) Loading space dimensions: minimum 12' × 45' with 14' vertical clearance.
 - c) Must be screened from public view and not located within required front setbacks.
 - d) Hours of loading adjacent to residential districts may be limited by the City.
- 2) Drive-Thru Stacking
 - a) Minimum stacking space size: 8' × 20'.
 - b) Required number of stacking spaces:
 - (1) Bank: 4 per lane
 - (2) Restaurant: 6 per lane
 - (3) Car wash: 4 per wash bay
 - c) Stacking areas shall not block drive aisles or required parking spaces.

I. Design Standards

- 1) Lots shall provide landscape screening and pedestrian connections per the landscape ordinance.
- 2) Accessible spaces must comply with ADA standards.
- 3) All required off-street parking spaces, drive aisles, and maneuvering areas shall be paved and permanently maintained with an all-weather, dust-free hard surface.

Sec. 14.04.005 Access and Connectivity.

- A. Purpose. Establish standards that create a safe, multimodal, and legible circulation network; minimize conflict points; extend the community street grid; and ensure that new development contributes its fair share toward a connected public realm.
- B. Applicability.
 - 1) Applies to all development requiring a site plan, conditional use permit, or building permit that alters site access, internal circulation, or frontage improvements.
 - 2) Where standards herein conflict with an adopted Street/Thoroughfare Plan, Transportation Master Plan (TMP), or state/federal access regulations, the most protective standard applies unless otherwise stated.
- C. Definitions.
 - 1) ADT (Average Daily Traffic): The total vehicles on a roadway in 24 hours, averaged over a representative period.
 - 2) Driveway: A private vehicular connection between a street and abutting property, including any curb return/flare.
 - 3) Drive Aisle: An internal private circulation lane serving on-site movement between parking, buildings, and access points.
 - 4) Full-Movement Driveway: A driveway allowing left-in, left-out, right-in, and right-out movements.
 - 5) RIRO (Right-In/Right-Out) Driveway: A driveway restricted to right turns only when entering from or exiting to the street.
 - 6) Corner Clearance: Distance along the traveled way from the intersecting street's curb-return tangent (or nearest edge of intersecting pavement where no curb exists) to the nearest edge of the driveway.
 - 7) Throat Length: The distance from the right-of-way line at a driveway to the first internal conflict point, intended to store on-site queues.
 - 8) Cross-Access: Vehicular, bicycle, and pedestrian connections between adjoining properties that allow movement without re-entering the public street; may be secured by a Cross-Access Easement.
 - 9) Internal Walkway: A paved, ADA-compliant pedestrian route on private property connecting primary entrances, parking areas, transit stops, and public sidewalks.
 - 10) Shared-Use Path: A two-way off-street facility for pedestrians and bicyclists (and other micromobility as permitted), generally 10 feet minimum unless otherwise approved.
- D. Internal Circulation. Drive aisles shall form a coherent network that connects all buildings, parking fields, loading/service areas, and access points. Dead-end drive aisles exceeding 150 feet shall provide a compliant turnaround.
- E. Site Access Management (Vehicular)
 - 1) Number of Driveways. Minimize driveways and locate them to maximize spacing from intersections. Corner lots shall place primary driveways on the lower-classified or secondary frontage.

2) Driveway Criteria and Spacing.

- a) Residential Driveways. A concrete driveway approach designed and intended to serve as access from a roadway to a lot or parcel of land which is a location for a one (1) or two (2) family residence.

Type	Driveway Width	Minimum Driveway Spacing
Single Family	12'-24'	1 driveway per property
Duplex/Townhome	12'-24'	10'

- b) Commercial Driveways. A concrete driveway approach designed and intended to serve as access from a roadway to a lot or parcel of land used for any development or purpose other than one or two family residences.

Street Type	One-Way Driveway Width	Two-Way Divided Driveway Width (each side of median)	Two-Way Undivided Driveway Width	Minimum Driveway Spacing
Local Street	15' min -20' max	20' min – 24' max	25' min – 40' max	100' min.
Major Collector	15' min -20' max	20' min – 24' max	25' min – 40' max	150' min.
Major Collector (4-Lane w/Median)	18' min -25' max	20' min – 24' max	30' min – 40' max	150' min.
MAD 4, MAD 6	18' min -25' max	20' min – 30' max	30' min – 45' max	200' min.
MAD 8	18' min-25' max	20' min – 30' max	30' min – 45' max	400' min.

- c) How to Measure. Driveway spacing is measured along the edge of the traveled way from the nearest edge of pavement of one driveway to the nearest edge of pavement of the next driveway. Corner clearance is measured along the edge of the traveled way from the tangent point of the intersecting street curb return (or the closest edge of the intersecting roadway pavement where no curb return exists) to the nearest edge of pavement of the driveway.
- d) Sight distance governs. If intersection/driveway sight distance, queueing, or auxiliary lane needs require larger values than the table, use the larger value.
- e) Engineering study. Where unique constraints exist, an engineering study may justify adjustments, provided safety and operations are maintained or improved (no reduction below Column (3) on non-frontage roads without shared access or physical RIRO).

- 3) Driveway Widths at ROW: Single-user access 12–24 ft; shared/multi-tenant 24–30 ft (max 36 ft only with demonstrated need). Provide curb radii or tapers per street class.
- 4) Throat Length (internal stacking). The throat storage length for high volume access driveways is directly related to the number of parking spaces accessible by the driveway. To determine the throat storage length, the total number of parking spaces shall be divided by the number of driveways and refer to table below. The calculation shall be used on the proposed number of parking stalls for an overall development or the number of parking spaces for an individual lot, whichever provides the more conservative ratio of parking stalls to driveways. This will ensure all departing cars can be stored adequately while waiting to exit the site.

Parking Spaces per Driveway	Storage Required (ft)			
	Multi-Family or Commercial Land Use		Industrial Land Use	
	Left Turn Allowed			
	No	Yes	No	Yes
<25	25	25	25	25
25-50	25	40	25	40
51-100	25	40	40	40
101-200	40	80	40	60
More than 200	100	150	40	100

- a) Throat length is measured from the property line to an interruption point. An interruption point consists of the first intersecting aisle, internal driveway, or parking stall.
 - b) For minor driveways that do not access a parking lot, the length of the driveway must fully incorporate the length of one parked vehicle or 20 ft.
 - c) For sites with structured parking, the throat length may be reduced to 0 ft. if queueing areas are demarcated to prevent turning conflicts for queued vehicles.
- 5) Shared Access & Consolidation. Where spacing cannot be met, sites shall consolidate access with adjoining lots via shared driveways and cross-access (see Subsection G). New development along an arterial shall first pursue shared access before requesting a new curb cut.
 - 6) TxDOT/State Facilities. Access to state highways shall comply with TxDOT driveway rules; where stricter, City standards govern internal circulation and cross-access.

F. Pedestrian Connectivity

- 1) Frontage Sidewalks. Sidewalks shall be provided along all public and private street frontages at the width specified by the adopted street type cross-sections (and in accordance with Section 14.04.001) and shall connect to existing sidewalks on abutting sites.
 - 2) Internal Walkways. Provide an on-site pedestrian network that:
 - a) Connects each primary building entrance to the public sidewalk, parking fields, transit stops, and on-site amenities.
 - b) Includes safe, direct walkways across parking areas at least every 200 ft of row length or per parking module, whichever is less.
 - c) Provides a walkway minimum 6 ft wide along building façades with customer entries.
- G. Crossings & Protection. Crosswalks across drive aisles/driveways shall be marked and, where ADT or design speed warrants, enhanced with raised tables, special paving, or refuge islands. Curb ramps and cross-slopes shall be ADA-compliant.
- H. Cross-Access Between Sites
- 1) Easements. Adjacent nonresidential and mixed-use sites shall grant and record perpetual cross-access easements to allow vehicles, bicycles, and pedestrians to travel between sites without re-entering the public street.
 - 2) Drive Aisle Standards. Cross-access drive aisles shall be 24 ft minimum (two-way) or 12 ft (one-way with signing/markings) and remain open during business hours of the connected uses.
 - 3) Staging & Deferral. Where an adjacent property is undeveloped, the applicant shall build drive aisles and sign them as “future connection,” with curb/fence removable upon adjacent development.
- I. Bicycle Connectivity
- 1) Consistency with Adopted Plans. Site design shall align with the City’s adopted Transportation Master Plan (TMP) and any Bikeway/Trails Plan. Where a planned bicycle facility or shared-use path is mapped along the site’s frontage or through the property, the development shall dedicate the necessary right-of-way or easement and construct the facility per City standard details in accordance with Section 14.04.001 or, if approved by the Director, pay the fee-in-lieu toward the sidewalk fund.
 - 2) Crossings of Driveways and Aisles. Where a bicycle/shared-use path crosses a driveway or internal drive aisle, provide a continuous, direct alignment with marked crossings and visibility measures consistent with City standards. Intersection and driveway treatments (markings, geometry, traffic calming) shall prioritize the safety of path users and comply with ADA requirements.
 - 3) Barriers & Fencing. Walls or fences along mapped path corridors shall include openings or gates to maintain the required public connections, with sight-distance and protection elements per City detail.
 - 4) Wayfinding & Lighting. Where a path segment is provided, install City-standard wayfinding and lighting as applicable to the facility type and context identified in the Street & Frontage Standards.

- 5) Maintenance. Path segments located on private property shall be maintained by the property owner unless and until accepted by the City.
 - 6) Alternative Alignment. When physical constraints (e.g., floodways, heritage trees, utilities, railroads) prevent the mapped alignment, the Director of Development Services may approve an alternative that preserves network continuity and delivers substantially equivalent access and safety, supported by an Access & Connectivity Plan.
- J. Transit Access (Where Applicable)
- 1) For sites fronting corridors with existing or programmed transit service, coordinate with the transit provider to provide bus stop pads, ADA connections, and, where warranted by ridership thresholds, shelters and lighting integrated into the frontage.
- K. Emergency Access & Fire Lanes
- 1) Provide fire apparatus access roads per the City's adopted Fire Code.
 - 2) Dead-end fire lanes over 150 ft require an approved turnaround. Fire lane markings/signage shall be maintained in perpetuity.
- L. Parking Interface & Street Loading
- 1) Head-in or back-out parking directly to an arterial or collector is prohibited.
 - 2) Loading and service areas shall be sited to minimize conflicts with pedestrian routes and screened per the Screening & Landscaping standards. Service vehicle movements shall not block required pedestrian connections.
- M. Traffic Impact Analyses (TIA) & Mitigation
- 1) Definition and Scope. Traffic Impact Analysis (TIA).
 A Traffic Impact Analysis is a technical report, prepared, signed, and sealed by a professional engineer licensed in the State of Texas with experience in traffic engineering, that evaluates the transportation impacts of a proposed development or change in zoning/intensity. An ITE-standard TIA shall be prepared in accordance with the current Institute of Transportation Engineers (ITE) Trip Generation Manual and ITE's Recommended Practice for Transportation Impact Analyses, and shall, at a minimum:
 - a) describe the proposed project, phasing, and study area (to include nearby intersections within ½ mile);
 - b) estimate trip generation, distribution, and assignment using ITE or approved local trip rates;
 - c) document existing and forecast traffic conditions for "no-build" and "build" scenarios;
 - d) provide capacity and operations analysis for key intersections and access points; and
 - e) identify proportionate mitigation measures and access, circulation, and safety recommendations, with supporting figures and worksheets.
 - 2) Triggers. A TIA is required when a proposed development or change in zoning/intensity is expected to generate ≥100 new peak-hour trips or ≥1,000 new average daily trips, based on ITE or approved local trip

rates, or when determined by the City Engineer or City Council due to safety or operational concerns.

When required, a TIA shall be submitted with the first applicable application, including:

- a) zoning map amendments (rezonings), including Planned Development Districts (PDDs), where the requested zoning would reasonably allow that level of intensity, as determined by the Director or City Engineer;
- b) preliminary plats;
- c) site development plans; and
- d) any other discretionary development application identified by the Director or City Engineer.

3) Traffic Memorandum (Traffic Memo)

A Traffic Memorandum is a concise, letter-format traffic analysis prepared, signed, and sealed by a professional engineer licensed in the State of Texas with experience in traffic engineering. A Traffic Memo may be required in lieu of a full Traffic Impact Analysis (TIA) for lower-intensity developments or rezonings that do not meet the TIA trip thresholds but raise localized safety or operational concerns. At a minimum, a Traffic Memo shall:

- a) briefly describe the proposed project, access points, and surrounding street network;
- b) estimate daily and peak-hour trip generation using the current ITE Trip Generation Manual or approved local data;
- c) qualitatively assess trip distribution, access, sight distance, and potential conflict points;
- d) provide a screening-level review of impacts at key intersections or driveways, using available volume or crash data where appropriate; and
- e) identify any recommended access, circulation, signing/stripping, or minor geometric improvements to address site-related safety or operational issues.

4) Proportionate Mitigation. Applicants shall dedicate right-of-way and construct or fund on- and off-site transportation improvements that are roughly proportionate to the development's impacts as determined by the City Manager and Director of Development Services, consistent with state law.

Timing/phasing may be established through an agreement.

- a) The responsibility of the developer for mitigation does not diminish the requirements of roadway impact fees set forth in Article 13.12 of the Bastrop Code of Ordinances, unless they have established an offset or credit to fees otherwise due.

N. Submittal Requirements

- 1) Access & Connectivity Plan showing all proposed and future stubs, sidewalks, trails, bicycle facilities, transit elements, and cross-access connections within 200 ft of the site boundaries.
- 2) Draft instruments for any required easements (public access, cross-access, sidewalk/trail) and shared access agreements.
- 3) If applicable, TIA with recommended mitigation, phasing, and cost participation.

O. Enforcement & Phasing

- 1) Required frontage, sidewalk, cross-access, and internal pedestrian/bicycle connections shall be constructed prior to Certificate of Occupancy for the associated phase, unless deferred by approved agreement.
- 2) Where a future connection is required but not yet constructible due to off-site constraints, the developer shall construct the on-site portion to the property line and record the easement, with temporary measures (removable curb/planter or gate) installed until connection is opened.

Sec. 14.04.006 Accessory Uses and Structures.

A. Purpose. Allow customary accessory uses and accessory dwelling units (ADUs) to broaden housing choices while protecting neighborhood and rural character. This section sets clear limits on size, height, placement, and design. All accessory structures count toward lot coverage, impervious cover, and parking requirements.

B. Applicability.

- 1) Applies on any lot that already has a principal use or principal building.
- 2) All accessory uses and structures must be incidental and clearly secondary to the principal use on the same lot.
- 3) ADUs are allowed only on lots with a single family dwelling or a duplex, and only as provided in Section G.

C. Definitions

- 1) Accessory Use. A use customarily incidental and subordinate to the principal use, located on the same lot.
- 2) Accessory Structure—Residential. A non-dwelling structure serving a residence (for example, garage, carport, storage building, pool house, workshop, pergola, greenhouse).
- 3) Accessory Structure—Nonresidential. A subordinate structure serving a nonresidential use/commercial use (for example, detached storage, equipment enclosure, refuse or recycling enclosure, detached canopy).
- 4) Accessory Dwelling Unit (ADU). A self-contained dwelling that is secondary to the principal dwelling on the same lot, with its own kitchen, bathroom, and sleeping area; may be detached, attached, or located above a garage.

D. General Standards (All Accessory Structures)

- 1) Timing. No accessory structure may be used or occupied before the principal structure is established.
- 2) Front Yards. Accessory structures are prohibited in a required front yard, except detached garages oriented to an alley.
- 3) Separation. Maintain a minimum of ten feet between buildings on the lot unless constructed with required fire-rated assemblies.
- 4) Easements and Visibility. No encroachments into recorded easements or visibility triangles.
- 5) Utilities and Drainage. Maintain drainage paths and access to meters and cleanouts; screen rooftop or pad-mounted equipment as required by this Code.

- 6) Coverage and Impervious Limits. All accessory structures (including ADUs) count toward district maximum lot coverage and impervious cover (see zoning district standards).
- 7) Historic Review. Within designated local historic districts or landmarks, additional review applies under the Historic Preservation Ordinance.
- 8) Height Measurement. Heights are measured per the definition of Building Height in Article 14.14.

E. Accessory Structure—Residential

- 1) Maximum Height.
 - a) Single-Family (SF) and Mixed Use (MU) districts: 20 feet (one story); up to 24 feet for a garage with a pitched roof matching the principal roof pitch.
 - b) Rural Residential (RR) districts: 24 feet (one story) or 35 feet for agricultural accessory buildings.
- 2) Setbacks (minimum).
 - a) Single-Family (SF) and Mixed Use (MU) districts:
 - (1) 5 feet side setback
 - (2) 5 feet rear setback
 - (3) 10 feet corner side setback
 - (4) not permitted in the front yard
 - b) Rural Residential (RR) districts:
 - (1) 10 feet side setback
 - (2) 10 feet rear setback
 - (3) 15 feet corner side setback
 - (4) not permitted in front yard
- 3) Design and Placement.
 - a) Where alleys exist, orient detached garage doors to the alley when feasible.

F. Accessory Structure—Nonresidential

- 1) Location. Place to the side or rear of the principal building and behind the front building façade.
- 2) Maximum Height. Twenty-four (24) feet.
- 3) Setbacks.
 - a) 5 feet side setback
 - b) 5 feet rear setback
 - c) 10 feet corner side setback
 - d) not permitted in the front yard

G. Accessory Dwelling Units (ADUs)

- 1) Eligibility. ADUs are allowed only on lots with an established single family dwelling or a duplex.
 - a) Rural Residential (RR) and Mixed Use Districts:

- (1) Up to two ADU's are allowed by-right on any Rural Residential or Mixed Use zoned lot, provided parking and impervious cover requirements are met.
- b) Single-Family (SF) districts:
 - (1) One ADU is allowed by-right on any Single Family-zoned lot, provided parking and impervious cover requirements are met.
 - (2) A second ADU may approved with a Conditional Use Permit on any Single Family-zoned lot, provided parking and impervious cover requirements are met.
- c) No more than two ADU's may be allowed on a lot.
- 2) Types. Detached (including above a detached garage), attached to the principal dwelling, or internal conversion (within the existing house or garage) with a separate code-compliant entrance.
- 3) Maximum Size (each ADU, gross floor area)
 - a) Standard: up to 1,000 square feet or 60 percent of the principal dwelling's conditioned floor area, whichever is less.
 - b) Rural Residential zoned lots greater than one acre: may increase to 1,500 square feet (regardless of percentage).
 - c) Attached ADU's and Internal Conversions: An attached ADU, including an ADU created by internal conversion of existing conditioned space within the principal dwelling (without additions), shall not exceed one thousand (1,000) square feet or fifty percent (50%) of the principal dwelling's conditioned floor area, whichever is less, and the principal dwelling shall remain the larger unit.
- 4) Height. Maximum 24 feet and no more than two stories.
- 5) Setbacks (detached ADUs)
 - a) Single-Family (SF) and Mixed Use (MU) districts:
 - (1) 5 feet side setback
 - (2) 5 feet rear setback
 - (3) 10 feet corner side setback
 - (4) not permitted in the front yard
 - b) Rural Residential (RR) districts:
 - (1) 10 feet side setback
 - (2) 10 feet rear setback
 - (3) 15 feet corner side setback
 - (4) not permitted in front yard
- 6) Privacy and Entries
 - a) Locate a primary ADU entry facing an alley or street, the principal dwelling, or an interior side yard; avoid facing a neighboring rear yard.

- b) Second-story balconies, decks, or rooftop terraces must be at least 10 feet from any side or rear lot line abutting a residential lot.
- 7) Parking. An ADU shall provide off-street parking at a ratio of one (1) space per ADU bedroom, which may be satisfied with existing on-site parking spaces to the extent the principal dwelling has surplus spaces beyond those serving the principal dwelling. If no surplus exists, additional spaces shall be provided to meet the one (1) space per ADU bedroom requirement. The principal dwelling is not required to be brought into compliance with current parking ratios, unless and until the principal dwelling is expanded or otherwise modified in a manner that triggers compliance with this Code's off-street parking requirements.
- 8) Utilities and Addressing. Utilities for an ADU shall be provided and metered in accordance with the requirements of the applicable utility provider. Addressing for an ADU shall comply with Bastrop 911 addressing requirements, including assignment of a secondary address when required. In the Rural Residential (RR) District, or on any lot served by an on-site sewage facility (OSSF), compliance with all applicable OSSF regulations is required prior to permit issuance.
- 9) Corner and Alley Lots.
 - a) Corner lots. If an ADU's primary entrance or primary facade faces the secondary frontage (corner side street), the ADU shall observe a setback from that frontage equal to the base zoning district's minimum front-yard setback.
 - b) Where an alley abuts the lot, vehicle access to an ADU garage shall be taken from the alley, unless the Director determines alley access is infeasible due to documented grade constraints, utility conflicts, or other physical site limitations.
- 10) Approvals and Alternative Compliance
 - a) By-right cases are approved by building permit. Conditional Use cases require Conditional Use Permit approval before a building permit.
- H. Prohibited
 - 1) Permanent commercial activity in an accessory structure within residential districts, except no-impact home based businesses.
 - 2) Shipping containers used as dwellings unless brought to full residential code compliance.
 - 3) A dwelling unit in any accessory structure unless it complies with the ADU standards in this section.
 - 4) Any accessory structure or ADU on a lot before the principal use or building is established.
- I. Enforcement and Maintenance. Accessory structures and ADUs must be maintained in good repair. Violations are enforceable under Chapter 14 as well as the City Nuisance and Building Codes (including stop-work orders, withholding of certificates of occupancy, fines, and abatement where applicable).

ARTICLE 14.05 LANDSCAPING REQUIREMENTS

Sec. 14.05.001 Minimum On-Site Landscaping Requirements

A. Purpose and Intent.

- 1) This Article establishes minimum landscaping, streetscape, tree preservation, and water-conservation standards to protect public health, safety, and welfare; manage stormwater; conserve water resources; preserve and expand urban tree canopy; buffer incompatible land uses; mitigate heat-island effects; and improve shade, comfort, and walkability consistent with the City's comprehensive plan.

B. Applicability and Exemptions.

- 1) **Applicability.** This Article applies to all development requiring site plan, building permit, or plat approval, including new development and redevelopment.
 - 2) **Redevelopment Threshold.** If a project results in a cumulative increase of the building footprint, paved/impervious area, or parking area on a site of twenty-five percent (25%) or more, the site shall be brought into compliance with current landscaping requirements as feasible, prioritizing:
 - a) frontage landscaping;
 - b) parking-lot interior landscaping; and
 - c) perimeter buffers.
 - d) **Feasibility Determination.** For purposes of this section, "feasible" means physically possible on the site as determined by the Director, considering existing buildings, required drive aisles and fire access, required parking and accessible routes, utilities and easements, drainage facilities, and visibility/safety requirements.
 - 3) **Exemptions.**
 - a) Single family dwellings or duplexes on individual infill lots are exempt except requirements under Section D.2.
 - b) Agricultural uses are exempt.
 - 4) **Planned Developments and Overlays.** Planned Development (PD) districts and Overlay districts shall comply with this Article unless alternative landscape standards are expressly adopted in the PD/Overlay ordinance; where conflicts occur, the adopted PD/Overlay controls.
- #### C. Definitions. Unless otherwise stated, terms have their commonly accepted meaning.
- 1) **Director:** The Director of Development Services or designee.
 - 2) **Caliper:** The diameter of a tree trunk measured four and one-half (4.5) feet above grade (DBH).
 - 3) **Canopy Tree:** A species typically attaining a mature height of thirty-five (35) feet or more with broad shade.
 - 4) **CO:** Certificate of Occupancy.

- 5) **Earthen Berm:** A linear mound of compacted, clean soil placed within a required landscape area or buffer to provide screening or a grade transition. Berms shall be stabilized with vegetation, graded for positive drainage, and constructed with side slopes no steeper than 3:1 (H:V) (4:1 where adjacent to sidewalks or public frontage) and a minimum top width of three (3) feet. Berms shall not be located within sight-visibility triangles, root protection zones, or drainage/overflow easements, and shall not obstruct drainage or flood flows. Berms are prohibited in FEMA-designated floodways and are allowed in the SFHA only with approval by the Floodplain Administrator and City Engineer and any required engineering certification. Berms may be combined with screening vegetation or fencing to meet buffer requirements.
- 6) **Effective Storage (ES):** The lesser of (i) rated tank volume, or (ii) 1.0 inch of rainfall over the connected roof area, multiplied by a 0.80 recovery factor. A five (5) day drawdown assumption is acceptable for sizing equivalency.
- 7) **Evergreen Screening:** A year-round visual screen made primarily of evergreen plant material from the City's adopted plant list, used to screen parking, service areas, or incompatible uses. Evergreen shrubs shall be at least 5-gallon and 24 inches tall at planting; evergreen trees, where used, shall be at least 2-inch caliper and 8 feet tall at planting. Plantings shall be installed to form a continuous hedge within a planting strip at least five (5) feet wide and shall be located outside sight-visibility triangles and in compliance with utility clearances. The screen shall achieve and maintain a minimum height of six (6) feet (or greater where otherwise required) and at least 80% opacity between three (3) feet above grade and the required height within three (3) years. Where utilities prevent a hedge, an equivalent screen may be approved using an evergreen vine on a fence or wall with supplemental plantings, provided the same height and opacity are achieved. Dead or declining plants shall be replaced by the next planting season. Invasive species, including running bamboo (*Phyllostachys* spp.), are prohibited.
- 8) **Masonry Wall:** A permanent, opaque screening wall constructed of brick, natural or cast stone, decorative concrete masonry units (CMU), or CMU with an integrally colored cementitious stucco finish. The wall must be on a continuous reinforced concrete footing and designed for lateral loads under the adopted building code. Freestanding walls must be reinforced masonry; brick or stone veneer is allowed only when anchored to structural CMU or concrete. Where visible from a public street or adjoining property, the wall must be finished on both sides and have a durable cap. Provide pilasters or offsets at changes in direction and at intervals of 30 feet or less. Exposed gray CMU is prohibited unless split-face or otherwise decorative with integral color. The wall must meet applicable height and opacity standards, be located outside sight-visibility triangles, and avoid utilities, easements (unless approved by the utility), and drainage or flood conveyance areas. The wall may not impede flood flows and is prohibited in FEMA floodways and in SFHAs unless all required approvals and certifications are obtained.

- 9) On Center (o.c.): Standard spacing measurement taken from the centerline of one element to the centerline of the next (e.g., shrubs planted at 36 inches o.c. are 36 inches apart, measured center-to-center).
- 10) Understory Tree: A species typically maturing below thirty-five (35) feet.
- 11) Root Protection Zone (RPZ): A circular area with a radius equal to one (1) foot for each inch of trunk caliper, measured from the trunk center.
- 12) Preservation Area: Undisturbed native vegetation designated on an approved plan and protected during and after construction.
- 13) Frontage Landscape: Required landscape area parallel and adjacent to a public right-of-way (ROW) but located on private property.
- 14) Xeriscape: Landscape designed for water efficiency through plant selection, soil improvements, and irrigation design.

D. Minimum Landscape Requirements

- 1) Required Landscape Area. Minimum landscape areas shall be provided per development type as specified in the Table below. Minimum landscape area shall be provided as a percentage of net lot area (lot area excluding dedicated public right-of-way).

Development Type	Minimum Landscape Area (percent of net lot area)
Townhouse / Small Multifamily (3–8 units)	20%
Multifamily (9+ units)	25%
Commercial / Office / Institutional / Mixed-Use	20%
Industrial / Employment	10%
Civic / Campus / Parks Support Facilities	20%

- 2) Residential Lots (Single Family Dwellings and Duplex). At least one (1) canopy tree shall be planted in the front yard within 10’ of the property line along the ROW; corner lots shall provide one (1) canopy tree along each street frontage outside sight triangles. At least two (2) shrubs shall be planted within the front yard (and corner side yard, if applicable) within 15’ of the property line along the ROW. Existing healthy native trees in the front yard may satisfy the tree requirement.

- a) Irrigated turf shall not exceed fifty (50) percent of the front-yard landscaped area.
 - (1) Front-yard landscaped area: The pervious area within the required front yard that is not covered by buildings or impervious surfaces (driveways, sidewalks, patios, decks, etc.).
 - (2) Irrigated turf: Turfgrass served by a permanent irrigation system (automatic irrigation or dedicated irrigated zone).
 - (3) The remaining required front-yard landscaped area shall be provided with a combination of native or drought-tolerant trees, shrubs, perennials, ornamental grasses, and groundcovers;

mulched planting beds; decorative rock or decomposed granite used in planted areas; and may include rain gardens or other landscaped stormwater features.

3) Credit for Existing Vegetation. Up to fifty (50) percent of the required landscape area may be satisfied by preserved, undisturbed native vegetation free of state-listed invasive species, provided Preservation Areas are delineated on plans, protected during construction, and recorded by easement. Designated tree preservation areas with at least fifty (50) percent native canopy may count at 1.5× area, provided the total credit under this subsection does not exceed fifty (50) percent.

a) This credit may be applied only toward the minimum required landscaped area. It shall not be used to reduce or substitute for required tree plantings, including required frontage (street) trees or parking lot trees.

E. Stormwater Basin/Channel Landscaping & Amenity Credit. Stormwater basins, channels, drainage easements, and floodways do not count toward required landscaped area. Up to 50% of the stormwater facility area may count only if the facility is amenitized as follows:

1) Public-edge buffer: Provide a 15-foot planted buffer along the public edge. Install shade trees at a minimum rate of one (1) tree per forty (40) linear feet of buffer length, and shrubs at a minimum rate of one (1) 3-gallon shrub per three (3) linear feet of buffer length, with ornamental grasses provided in groupings throughout the buffer.

2) Safety and function: Do not place woody plants on embankments or within required clear zones around hydraulic structures. Maintain required maintenance access and drainage function.

3) Public amenities: Provide a trail and seating, plus at least one amenity such as an overlook or aerating fountain.

F. Streetscape and Frontage Requirements

1) Location of Frontage Band. At least fifty (50) percent of the required on-site landscape area shall be within a continuous frontage landscape band a minimum of ten (10) feet in depth on private property along all street frontages.

2) Street Trees. Provide one (1) tree per forty (40) linear feet of frontage, planted three to five (3–5) feet inside the property line; spacing may be adjusted administratively between twenty (20) and forty (40) feet to avoid utilities and sight triangles. In downtown or constrained contexts, trees may be placed in tree wells with root paths or structural soil; tree grates are permitted.

3) Shrubs and Groundcovers. Provide shrubs in massed plantings within the frontage band at a minimum rate of one (1) 3-gallon shrub per three (3) linear feet, or an equivalent design shown on an approved planting plan that provides comparable coverage at maturity.

4) Alternative Compliance—Constrained Sites. Where existing buildings, utilities, or easements prevent full compliance, the Development Services Director may approve equivalent frontage landscaping through expanded tree wells, raised planters, additional shade trees, or interior islands, provided the total

required frontage area and frontage tree count are maintained and the minimum on-site landscaping percentage per development type remains satisfied.

- 5) ROW Restoration. Disturbed ROW adjacent to sidewalks or streets shall be restored and stabilized prior to CO with sod or a xeriscape palette using drought-tolerant species.

G. Parking-Lot Landscaping

- 1) Interior parking areas shall include landscape area equal to at least:
 - a) 10% of the total paved parking area for Commercial/Office/Institutional, Mixed-Use, and Multifamily; and
 - b) 5% of the total paved parking area for Industrial;
 - c) Required percentages above are exclusive of perimeter landscape strips and buffers. Islands, linear islands, and green-infrastructure islands may be counted toward this requirement. Where a percentage in this subsection and the island frequency requirements both apply, the more restrictive outcome governs.
- 2) Soil Volumes for Urban Tree Wells / Planters. Tree wells or raised planters in constrained/urban contexts may count as landscape area only where a minimum soil volume of 600 cubic feet per canopy tree and 300 cubic feet per understory tree is provided, which may be satisfied by structural soil or root paths.
- 3) Interior Islands and End-Caps. Provide a landscape island at both ends of each parking row and at least one (1) landscape island for every one hundred and twenty (120) linear feet. Each island shall be a minimum of three hundred (300) square feet and ten (10) feet in width, with one (1) canopy tree per island.
 - a) For Industrial zones: Provide a landscape island at one (1) end of each parking row and at least one (1) landscape island for every two hundred (200) linear feet of parking row. Each island shall be a minimum of three hundred (300) square feet and ten (10) feet in width, with one (1) canopy tree per island.
- 4) Linear Islands. In lieu of discrete islands, a linear island of at least six hundred (600) square feet and ten (10) feet in width with two (2) shade trees may serve a single parking aisle of up to 240 linear feet (or 400 linear feet in Industrial zones).
- 5) Green-Infrastructure Islands. Where feasible, curb cuts or flush curbs shall convey runoff into islands designed as bioretention features with amended soils. If tested infiltration is less than 0.5 inches per hour, or the seasonal high-water table is within twenty-four (24) inches of the media bottom, an underdrain shall be provided to the storm system.
- 6) Perimeter Screening. Where a commercial parking area abuts a public right-of-way or a property zoned or used for residential use (including mixed-use), provide a minimum 10-foot perimeter landscape strip between the parking area and the ROW or property line. Plant the strip with one (1) canopy tree per thirty (30) linear feet and a headlight screen consisting of 5-gallon shrubs 5-gallon shrubs shall be planted at a

maximum spacing of thirty-six (36) inches on center (staggered as needed) to form a continuous headlight screen, and maintained at a maximum height of 36 inches.

- a) A required frontage landscape strip or other required buffer may satisfy this requirement if it is located between the parking area and the ROW or residentially zoned property and meets or exceeds the width and planting standards of this subsection; required plantings may be counted once.
- 7) EV Charging Equipment Placement. Electric vehicle (EV) charging pedestals and associated equipment shall be located so as not to conflict with required tree growth or RPZs; a minimum five (5) foot clear radius around tree trunks at maturity shall be maintained. EV pedestals should be sited in end-caps or behind wheel stops outside required tree planting areas.
- 8) Relationship to Percentage Minimum. Where compliance with all sections yields total landscape area less than the percentage required by Sec. 14.05.001(D)(1), additional islands, linear islands, or bioretention areas shall be added to meet the percentage. Where it yields more, no reduction is permitted below the adopted standards.

H. Buffers Between Unlike Land Uses

- 1) Required buffers shall be provided along side and rear lot lines as follows:
 - a) Industrial abutting Residential or Mixed Use: thirty (30) feet wide landscape buffer with an earthen berm or masonry wall and evergreen screen capable of reaching six (6) feet in height within three (3) years; planted eight to ten (8–10) feet on center.
 - b) Industrial abutting Commercial: twenty (20) feet with earthen berm or masonry wall and evergreen screen capable of reaching six (6) feet in height within three (3) years; plant eight to ten (8–10) feet on center.
 - c) Commercial abutting Single Family Residential: fifteen (15) feet with evergreen screening.
 - d) Remaining pre-existing native vegetation may count towards the buffer requirement, supplementing additional vegetation as needed.
 - e) Loading Docks: 15-foot landscape buffer with an 8-foot opaque masonry wall (10-foot when abutting residential) and a continuous evergreen hedge in a ≥ 5 -foot planting strip, planted at ≤ 36 -inch o.c., achieving $\geq 80\%$ opacity within 3 years.
- 2) Scenic Corridors. Along any frontage on a TxDOT right-of-way, planted inside the private property line, provide a 20-foot frontage buffer with one (1) canopy tree per 30 linear feet. The buffer shall also include layered plantings, meaning a combination of understory trees and shrubs installed as follows: one (1) understory tree per 60 linear feet and shrubs at a minimum rate of one (1) 3-gallon shrub per three (3) linear feet, arranged in groupings within mulched planting beds. Turf, if any, is limited to pedestrian access and does not satisfy the layered planting requirement.

I. Tree Protection and Mitigation

- 1) Tree preservation, protection fencing, construction within RPZs, removals, and mitigation shall comply with, Article 6, Tree Preservation and Mitigation. Where this Article is more restrictive, this Article controls.
- 2) Credits. Preserved trees that meet spacing and health standards may be credited toward parking-lot tree and frontage tree requirements when located within required landscape areas.

J. Minimum Planting Standards

- 1) Plant Quality. All plant materials shall conform to ANSI Z60.1 and be nursery-grown, free of pests and disease, and typical of their species.
- 2) Installation. Set trees with the root flare at finished grade; apply mulch two to three (2–3) inches deep, kept at least three (3) inches from trunks.
- 3) Utilities and Sight Distance. Trees shall not be planted within ten (10) feet of fire hydrants or five (5) feet of underground utilities; all plantings must be outside sight-visibility triangles; species/placement shall avoid overhead utility conflicts.

K. Root Protection Zones

- 1) Protection Intent. Root zones shall remain protected and undisturbed for preserved trees, and new plantings shall be sited and detailed to provide appropriate soil volume and space for healthy root establishment and growth.
- 2) Root Protection Zone (RPZ). For purposes of this Code, the RPZ is a circular area with a radius equal to one (1) foot for each inch of trunk caliper, centered on the trunk, unless a Tree Protection Plan prepared by an ISA-Certified Arborist establishes a different radius based on species and site conditions.
- 3) Protection Fencing. Prior to any land disturbance, the RPZ of all preserved trees shall be enclosed with four (4) foot-high chain-link or welded-wire fencing supported by steel posts at eight (8) feet on center, with “Tree Protection Area – Keep Out” signage posted at one per 50 feet of fence or minimum one per tree. Fencing shall remain in place until Final landscape inspection unless released in writing by the Director.
- 4) Prohibited Activities Within the RPZ. Within the RPZ, the following are prohibited: grading; cuts or fills; trenching; compaction by vehicles or equipment; parking or materials storage (including soil, rock, equipment, or dumpsters); concrete wash-out; fuel, paint, or chemical mixing; fires; and installation of utilities, footings, slabs, or pavements.
- 5) Limited Encroachments (Methods). Where the Director determines that an encroachment into the RPZ is unavoidable, the following methods shall be used, and only to the minimum extent necessary:
 - a) Hand digging or pneumatic excavation (no mechanical trenchers) within the outer one-third of the RPZ.
 - b) Tunneling or directional boring for utilities beneath roots at a minimum twenty-four (24) inches below existing grade (or below the majority root plate if known).

- c) Root pruning only as necessary to complete the work, with clean cuts performed by or under the supervision of an ISA-Certified Arborist; cut surfaces shall be immediately backfilled and watered.
- d) Total encroachment area shall not exceed thirty (30) percent of the RPZ.
 - (1) Any encroachment into the RPZ shall be the minimum extent necessary and must be approved by the Director after determining unique site constraints result in unavoidable encroachment.
 - (2) Encroachments greater than 30% into the RPZ may be approved by the City Arborist and/or the Director of Parks and Recreation only when the Applicant submits an enhanced tree care plan, and the Director of Parks and Recreation and/or City Arborist determines the plan is adequate to protect tree health and long-term viability.
- 6) Grade Changes Over Roots. No cuts are permitted within the RPZ. Fills over the RPZ are limited to three (3) inches of pervious topsoil and mulch combined; impermeable surfaces are prohibited unless a Tree Protection Plan provides engineered aeration/soil-cell measures approved by the Director.
- 7) Remediation for Accidental Compaction or Disturbance. If compaction or disturbance occurs within the RPZ, the Director may require remediation consisting of pneumatic soil decompaction or radial trenching (8–12 inches deep) and incorporation of compost at 2–4 inches over disturbed areas, followed by deep watering and mulch.
- 8) New Tree Planting Required Soil Volume and Space. New trees shall be located and detailed to provide adequate, contiguous soil volume: 600 cubic feet per canopy tree and 300 cubic feet per understory tree minimum (which may be shared by adjacent trees if volumes are contiguous). In parking lots or other constrained or paved areas, equivalent volumes may be provided via structural soil, soil cells, or root paths beneath pavements. Minimum planter widths: eight (8) feet for canopy trees and five (5) feet for understory trees, unless a Tree Protection Plan demonstrates equal or better performance.
- 9) Hardscape and Equipment Setbacks. No EV charging pedestals, transformers, or similar equipment shall be placed within required tree planting areas or within the five (5) foot clear radius around tree trunks needed for growth and maintenance. Pavement edges, curbs, and walls shall be detailed to keep mulch off trunks and maintain the visible root flare at finished grade.
- 10) Utilities and Irrigation Near Roots. Irrigation mains and lateral lines shall be routed outside the RPZ where feasible; if crossing is unavoidable, lines shall be bored beneath roots as in Subsection 5(b). All utility separations and hydrant clearances remain applicable.
- 11) Tree Wells and Planters (Urban Conditions). Tree wells or raised planters used to satisfy landscape requirements shall include aeration and drainage features, maintain the root flare at finish grade, and meet the soil-volume requirements in Subsection 8. Where planters are adjacent to paving, provide root paths/soil connections to adjacent landscape or soil-cell areas.

- 12) Documentation and Field Verification. The Landscape Plan shall delineate RPZs for preserved trees and show fencing, boring/tunneling notes, and soil-volume diagrams for new trees. Compliance shall be verified at Pre-construction (fencing installed), during Utility rough-in (if applicable), and at Final.
- 13) Damage, Survival, and Mitigation. If a preserved tree suffers decline or mortality attributable to RPZ disturbance within two (2) years of CO, the Director may require mitigation or replacement per the Tree Preservation Article and may draw on posted maintenance bonds where applicable from Subsection N(4) (ROW or accepted common areas).
- 14) Alternative Compliance (Arborist Plan). The Director may approve modifications to RPZ dimensions, methods, or soil volumes only upon submittal of a Tree Protection Plan sealed by an ISA-Certified Arborist that demonstrates equal or superior long-term tree health and public safety outcomes.

L. Soils, Irrigation, and Water Conservation

- 1) Soils. Landscape areas shall contain a minimum six (6) inches of quality topsoil or amended soil; compacted subgrades shall be scarified prior to amendment.
- 2) Irrigation. Provide separate zones for turf, trees, and beds; use drip or subsurface irrigation for shrubs/trees/beds; no overhead spray within twenty-four (24) inches of impervious surfaces. Systems should include a weather-based smart controller and rain shut-off device and shall be inspected prior to CO.
- 3) Water Conservation. At least fifty (50) percent of plant materials (excluding turf) shall be native or drought-tolerant from the City's Adopted Preferred Plant List. High-water-use turf grass on nonresidential sites shall not exceed fifty (50) percent of total landscaped area. Rock/gravel may be used as an accent only, not to exceed twenty-five (25) percent of any landscaped area.

M. Landscape Plans, Submittals, and Alternative Compliance

- 1) Landscape Plan. A sealed landscape plan prepared by a licensed professional Landscape Architect shall be submitted with the site plan and show:
 - a) Calculations of required areas;
 - b) Plant schedule (species, size, quantity);
 - c) Preserved trees;
 - d) Irrigation plan;
 - e) Preservation Areas and RPZs;
 - f) LID features and any credits elected under Sec. 14.05.002;
 - g) Visibility triangles and utilities; and
 - h) Maintenance notes.
 - i) Plans electing cistern (rainwater harvesting) credits shall delineate the Connected Roof Area (square feet) with a polygon and label. The plan shall include tabulations demonstrating compliance with

Table in Sec. 14.05.002(G), including the net lot area used for calculation and the gross paved parking area used for interior-landscape calculations.

- 2) Single-Family Dwellings and Duplex's. The required frontage trees and shrubs must be shown on the site plan/plot plan submitted with the building permit. The plan need not be prepared or sealed by a landscape architect, but must comply with all specifications of this Article (including species, quantities, spacing, and installation details).

N. Maintenance, Inspection, and Bonding

- 1) Timing. All required landscaping shall be installed prior to CO; when seasonal conditions prevent planting, the City Manager or designee may accept a landscape surety equal to one hundred twenty-five (125) percent of the estimated installed cost.
- 2) Maintenance. Owners shall maintain plantings and irrigation in a healthy condition; dead plant material shall be replaced within ninety (90) days, or by the next planting season if replacement within ninety (90) days is impractical. During municipally declared drought stages, replacement deadlines are extended to the next planting season; hand-watering and drip irrigation for establishment are permitted notwithstanding landscape-irrigation restrictions.
- 3) Inspections. Tree-protection fencing shall be installed and inspected prior to land disturbance; a final landscape inspection is required prior to CO; the City may reinspect for establishment within twenty-four (24) months of CO and require replanting if any plants are found to be dead or dying.
- 4) Bonding.
 - a) Private Frontage Trees. Where all required street trees are planted inside the private property line, no maintenance bond is required. The owner shall pass final inspection prior to CO issuance and provide an eleven-month establishment affidavit within eleven (11) months after the date of the Certificate of Occupancy.
 - b) ROW/Common-Area Landscaping Accepted with Public Improvements. Prior to acceptance, the developer shall post a two (2) year maintenance bond at 100% of the installed cost covering trees and landscaping in ROW or common areas accepted with roadway or subdivision improvements.

Sec. 14.05.002 Low Impact Development Landscaping Credits.

- A. Purpose. Provide standard, predictable credits that reduce otherwise required landscape area or allow substitutions when on-site LID achieves equal or better outcomes for shade, cooling, and stormwater management.
- B. Applicability. Credits in Standardized LID & Rainwater Credits Table may be elected for nonresidential and multifamily development.
- C. Administration. Credits shall be granted ministerially consistent with the table in Subsection G, verified at Site Plan and in the field prior to CO.

- D. Cap. Total LID credits cannot reduce required landscape area by more than 50%. Notwithstanding any credit, the required frontage tree count in Sec. 14.05.001(F) shall not be reduced.
- E. O&M. All credited LID facilities shall be maintained per a recorded LID O&M Affidavit naming a responsible party and minimum inspection frequency.
- F. Effective Storage for Cisterns (rainwater harvesting barrels). For Table below, Effective Storage (ES) = the lesser of (i) rated tank volume, or (ii) 1.0 inch of rainfall over the connected roof area, multiplied by a 0.80 recovery factor. A five (5) day drawdown assumption is acceptable for sizing equivalency.
- G. Table: Standardized LID & Rainwater Credits

No.	Measure	Credit
1	Cistern (rain barrel) for non-potable irrigation	Reduce required landscape area 5% per 1,000 gal ES, up to 50% max total required landscaped area.
2	Bioretention parking-lot island(s) receiving pavement runoff	Each qualifying island counts at 150% of its plan area toward the interior-parking landscape minimum; total credit up to 25% of the required landscaped area.
3	Permeable frontage swale or bioretention strip	25% credit toward the required frontage landscaping requirement

- H. Inspection. The City shall verify installation of credited measures at Final and may reinspect within twelve (12) months of CO.
- I. Bonding. Credited improvements in ROW or HOA common areas accepted with public improvements shall be covered by the applicable two-year maintenance bond under Sec. 14.05.001(N.4). Credits located solely on private property are not bonded but remain subject to maintenance and reinspection.

Sec. 14.05.003 Adopted Lists

- A. Adopted Preferred Plant List and Prohibited Species. The “City of Bastrop Adopted Preferred Plant List” and “Native (Protected) and Invasive Plant List,” may be amended by resolution, and are adopted by reference and maintained in the Appendix.

ARTICLE 14.06 TREE PRESERVATION AND MITIGATION

Sec. 14.06.001 Purpose and Intent

- A. Conserve and enhance the City's trees to protect neighborhood character, public health, stormwater management, urban heat mitigation, and wildlife habitat.
- B. Establish clear standards for tree surveys, preservation zones, critical root zone protections, mitigation, and enforcement.
- C. Provide reasonable flexibility to accommodate other development standards when doing so resulting in measurably better tree preservation outcomes.

Sec. 14.06.002 Applicability and Relationship to Other Codes

- A. Applicability. This Article applies to all public and private development, redevelopment, and site work requiring a development permit, building permit, grading/clearing permit, or plat approval within the City limits (and ETJ where allowed by law).
- B. Conflicts. Where this Article conflicts with another adopted City standard, the Director may authorize the least-deviation solution that best preserves protected trees while meeting public safety, flood, and utility requirements.
- C. The procedures of the Tree Preservation and Mitigation Section are authorized under the authority granted by Texas Local Government Code Chapter 212.

Sec. 14.06.003 Permit Requirement and Validity

- A. Permit. A Tree Removal Permit is required before removing a Protected Tree or conducting a Tree Impact Activity.
- B. Validity. A Tree Removal Permit is valid for six (6) months from issuance.

Sec. 14.06.004 Submittals: Tree Survey and Removal/Preservation Plan

- A. Tree Survey, sealed by a Certified Arborist or Landscape Architect:
 - 1) Vicinity map; property boundaries and acreage.
 - 2) Existing/proposed streets, drainage, and utility easements on/adjacent to the property.
 - 3) Required preservation/buffer zones.
 - 4) Location, tag number, species, DBH, and condition of each preserved individual Protected Tree; identify Heritage/Significant Trees.
 - 5) Identification of areas proposed for clearing.
 - 6) Recent aerial imagery depicting pre-development conditions.
 - 7) All trees starting at 8 inches in diameter must be surveyed, if credit for preserved trees that are 6 inches in diameter or bigger is wanted, 6-inch diameter trees will also need to be surveyed.
 - 8) The information on the survey shall not be older than two years.

9) The tree survey and preservation plan is required for all areas of soil disturbance and construction activity including all work within rights-of-way and easements. The detailed tree survey shall be submitted at the time of public improvement plans, site development plans, or land disturbance, whichever is first.

However, if the site is larger than 5 acres, a preliminary tree survey will also be required at the time of a rezoning application, or PDD.

a) The preliminary tree survey shall include aerial photos and sampling.

(1) Recent color aerial (dated within 12–24 months), at 1"=100' or similar.

(2) Overlaid with: property boundaries, limits of work, major tree stands, and any proposed non-disturbance areas.

(3) Said Sample or sampling techniques should be representational of the site or wooded area and should comprise at least fifteen percent (15%) of the total site or wooded area and the sampling technique shall be approved by the Director of Development Services or designee prior to conducting the sample.

B. Tree Removal & Preservation Plan (drawn to site plan scale) must:

1) Overlay building footprints, drives, parking, detention, and utilities.

2) Delineate CRZ fencing and protection measures.

3) Identify mitigation, replacement, and/or Payment in Lieu option.

4) Provide irrigation plans for new plantings where required.

Sec. 14.06.005 Credits

A. For every healthy protected tree six (6) inches caliper or larger located outside of the flood plain that is preserved, the developer shall be given credit, according to the following chart.

DBH Class	Credit
6.0"–9.9"	1.0
10.0"–23.9"	1.5
≥24.0"	2.0

B. Healthy unprotected trees, over twelve (12) inches in size, located outside the floodplain, may be considered for tree credits only when individually field inspected and approved by the Parks Director or assignee.

Sec. 14.06.006 New and Replacement Tree Standards

A. Species. Select from the Protected Trees, Accepted Native Plants, and Invasive Species List in Appendix A. The Parks Director or assignee may approve of comparable species.

Sec. 14.06.007 Root Protection Zones

- A. Protection Intent. Root zones shall remain protected and undisturbed for preserved trees, and new plantings shall be sited and detailed to provide appropriate soil volume and space for healthy root establishment and growth.
- B. Root Protection Zone (RPZ). For purposes of this Code, the RPZ is a circular area with a radius equal to one (1) foot for each inch of trunk caliper, centered on the trunk, unless a Tree Protection Plan prepared by an ISA-Certified Arborist establishes a different radius based on species and site conditions.
- C. Protection Fencing. Prior to any land disturbance, the RPZ of all preserved trees shall be enclosed with four (4) foot-high chain-link or welded-wire fencing supported by steel posts at eight (8) feet on center, with “Tree Protection Area – Keep Out” signage posted at one per 50 feet of fence or minimum one per tree. Fencing shall remain in place until Final landscape inspection unless released in writing by the Director.
- D. Prohibited Activities Within the RPZ. Within the RPZ, the following are prohibited: grading; cuts or fills; trenching; compaction by vehicles or equipment; parking or materials storage (including soil, rock, equipment, or dumpsters); concrete wash-out; fuel, paint, or chemical mixing; fires; and installation of utilities, footings, slabs, or pavements.
- E. Limited Encroachments (Methods). Where the Director determines that an encroachment into the RPZ is unavoidable, the following methods shall be used, and only to the minimum extent necessary:
 - 1) Hand digging or pneumatic excavation (no mechanical trenchers) within the outer one-third of the RPZ.
 - 2) Tunneling or directional boring for utilities beneath roots at a minimum twenty-four (24) inches below existing grade (or below the majority root plate if known).
 - 3) Root pruning only as necessary to complete the work, with clean cuts performed by or under the supervision of an ISA-Certified Arborist; cut surfaces shall be immediately backfilled and watered.
 - 4) Total encroachment area shall not exceed thirty (30) percent of the RPZ.
 - a) Any encroachment into the RPZ shall be the minimum extent necessary and must be approved by the Director after determining unique site constraints result in unavoidable encroachment.
 - b) Encroachments greater than 30% into the RPZ may be approved by the City Arborist and/or the Director of Parks and Recreation only when the Applicant submits an enhanced tree care plan, and the Director of Parks and Recreation and/or City Arborist determines the plan is adequate to protect tree health and long-term viability.
- F. Grade Changes Over Roots. No cuts are permitted within the RPZ. Fills over the RPZ are limited to three (3) inches of pervious topsoil and mulch combined; impermeable surfaces are prohibited unless a Tree Protection Plan provides engineered aeration/soil-cell measures approved by the Director.
- G. Remediation for Accidental Compaction or Disturbance. If compaction or disturbance occurs within the RPZ, the Director may require remediation consisting of pneumatic soil decompaction or radial trenching (8–12

inches deep) and incorporation of compost at 2–4 inches over disturbed areas, followed by deep watering and mulch.

- H. **New Tree Planting Required Soil Volume and Space.** New trees shall be located and detailed to provide adequate, contiguous soil volume: 600 cubic feet per canopy tree and 300 cubic feet per understory tree minimum (which may be shared by adjacent trees if volumes are contiguous). In parking lots or other constrained or paved areas, equivalent volumes may be provided via structural soil, soil cells, or root paths beneath pavements. Minimum planter widths: eight (8) feet for canopy trees and five (5) feet for understory trees, unless a Tree Protection Plan demonstrates equal or better performance.
- I. **Hardscape and Equipment Setbacks.** No EV charging pedestals, transformers, or similar equipment shall be placed within required tree planting areas or within the five (5) foot clear radius around tree trunks needed for growth and maintenance. Pavement edges, curbs, and walls shall be detailed to keep mulch off trunks and maintain the visible root flare at finished grade.
- J. **Utilities and Irrigation Near Roots.** Irrigation mains and lateral lines shall be routed outside the RPZ where feasible; if crossing is unavoidable, lines shall be bored beneath roots as in Subsection 5(b). All utility separations and hydrant clearances remain applicable.
- K. **Tree Wells and Planters (Urban Conditions).** Tree wells or raised planters used to satisfy landscape requirements shall include aeration and drainage features, maintain the root flare at finish grade, and meet the soil-volume requirements in Subsection 8. Where planters are adjacent to paving, provide root paths/soil connections to adjacent landscape or soil-cell areas.
- L. **Documentation and Field Verification.** The Landscape Plan shall delineate RPZs for preserved trees and show fencing, boring/tunneling notes, and soil-volume diagrams for new trees. Compliance shall be verified at Pre-construction (fencing installed), during Utility rough-in (if applicable), and at Final.
- M. **Damage, Survival, and Mitigation.** If a preserved tree suffers decline or mortality attributable to RPZ disturbance within two (2) years of CO, the Director may require mitigation or replacement per the Tree Preservation Article and may draw on posted maintenance bonds where applicable from Subsection N(4) (ROW or accepted common areas).
- N. **Alternative Compliance (Arborist Plan).** The Director may approve modifications to RPZ dimensions, methods, or soil volumes only upon submittal of a Tree Protection Plan sealed by an ISA-Certified Arborist that demonstrates equal or superior long-term tree health and public safety outcomes.

Sec. 14.06.008 Mitigation, Replacement Calculation, and Payment in Lieu

- A. The City Manager, in conjunction with the Parks and Recreation Director, shall create a process and procedure for mitigating the removal of trees on private property by creating a permit process for tree removal.
- B. Upon inspection by the City Arborist, or a designated third-party arborist, persons seeking to remove a tree on the Native (Protected) and Invasive Plant list, that is over 10" in caliper 4.5 feet from the ground, shall be required to obtain a mitigation permit that is assessed according to the City Master Fee Schedule.

- C. This fee shall not be assessed to residents if:
 - 1) The tree is located on a property that is an existing one-family or two-family dwelling that is the person's residence; and
 - 2) If the tree is less than 10 inches in diameter at the point on the trunk 4.5 feet above the ground.
- D. Replacement trees shall be from the approved Preferred Plant list and shall equal out to be the same number of caliper inches removed from the site.
- E. Failure to replace caliper per caliper will result in mitigation fees being assessed.
 - 1) If the property owner removes a tree(s) that does not meet the requirements of Sec 14.06.008(C.) and is 10 inches in caliper measured 4.5 feet from the ground and is on the Preferred Plant list as Native and does meet the definition of a protected or a heritage tree the property owner will be required to replant one plant from the Preferred Plant List for each tree removed if it is the person's residence.
- F. Individuals commending tree removal without a permit, shall be assessed double the mitigation fee, and must meet the requirements to replace trees on a caliper per caliper inch basis.
- G. Replacement Calculation (per Protected Tree removed): In the event it is necessary to remove a tree ten (10) inches caliper or larger, the developer, builder or property owner shall be required to replace the tree to be removed with comparable or better spacious trees somewhere within the property, planned development or subdivision.
- H. Mitigation Methods (applicant may combine): on-site replacement; off-site replacement (parks, conservation areas, selected ROW, as approved by the City Council if it is deemed necessary by Parks Director and space is available); or Payment in Lieu to the City's Tree Mitigation Fund.
- I. Invasive Removal Incentive. When the applicant eliminates onsite/off-site invasive trees per Appendix A, the Director may allow the applicant to receive invasive species credits. All invasive species identified by an ISA-certified arborist may receive an invasive species credit of 1/2 credit for every inch of invasive tree being removed.
- J. Timing & Security. Replacement trees must be planted within 1 year of permit issuance. For Payment in Lieu elections tied to later planting upon approval from Director, provide a cash escrow, bond, or letter of credit equal to the full amount; release occurs after verified planting.

Sec. 14.06.009 Appeals

An individual may request relief to any part of this section to the City Manager within 15 business days with documentation supporting the requested adjustment. If the appeal is denied, the individual may appeal to the City Council within 15 business days of City Manager's decision. The decision of City Council shall be final.

Sec. 14.06.010 Exemptions

Any tree determined to be diseased, overly mature, dying or dead, by an ISA certified arborist or if it poses an imminent or immediate threat to persons or property is exempted from the Standards of this Code.

Sec. 14.06.011 Fees and Penalties

- A. Fees shall be established by the Master Fee Schedule.
- B. Any individual who removes trees without a permit, or does not comply with the mitigation requirements of Article 14.06 shall be subject to a \$500 to \$2000 fine, per tree, per offense and shall be charged with a misdemeanor offense.

ARTICLE 14.07 SIGNS

Sec. 14.07.001 Intent & Purpose

Regulate signs visible from the public realm to ensure context-appropriate size, placement, and legibility; protect safety and aesthetics; and provide clear information to pedestrians and drivers. A sign permit authorizes the display, erection, alteration, relocation, or replacement of on-premise or off-premise signs, unless exempt.

Sec. 14.07.002 Applicability & Jurisdiction

This Article applies to all property in the City limits and, within the statutory ETJ.

Authority. This article is adopted pursuant to the City of Bastrop's authority as a Home-Rule Municipality under the Texas Constitution, the Texas Local Government Code Chapter 216, and other applicable state and federal laws.

Sec. 14.07.003 Administration

- A. Permit Required. No sign may be installed, altered, or moved without a sign permit, except for signs expressly allowed without a permit in this Article or the permitted/allowed table.
- B. Permits & Fees. Permits are issued to the property owner or authorized agent. Fees are as adopted by the City Master Fee Schedule.
- C. Interpretation. The Director of Development Services administers and interprets this Article.
- D. MSP (Master Sign Plan) may be approved for master-planned communities and multitenant or multi-lot nonresidential projects to ensure coordinated, high-quality sign design.
- E. Enforcement. Each violation is a separate offense. The City may remove signs that pose an immediate public hazard or violate specific provisions (e.g., R.O.W.) and recover costs.

Sec. 14.07.004 General Standards

- A. Location. Signs must be on private property (outside public R.O.W.), on developed sites or those with an active building permit, and outside visibility/sight triangles.
- B. Construction & Installation. Comply with IBC/NEC and City standards. Permanent signs must be built of durable materials, securely anchored, and designed for required wind and dead loads.
- C. Maintenance. Signs shall be kept in good repair (including lighting components). The Building Official may order repair or removal of signs constituting a nuisance; failure to comply may result in City abatement and cost recovery.

Sec. 14.07.005 Measurement

- A. Area. Measure the smallest rectangle(s) encompassing each word/graphic for individual letters/graphics; count the full illuminated panel when sign is on/within an illuminated element; for multifaced signs at $\leq 30^\circ$ count one face; at $>30^\circ$ sum both faces; for 3–4 faces count 50% of the total.
- B. Height. For freestanding signs, measure from finished grade at the sign base (including berms used to increase height) to the top of the sign; for building-mounted signs, from base of the wall to top of sign.

Sec. 14.07.006 Illumination

- A. Allowed illumination types: internal, halo (internal indirect), and external shielded down-lighting.
- B. Prohibited effects: flashing, chasing, strobing, revolving beacons, moving parts.
- C. Performance. Internally lit signs: only allowed in signs that are within 200 feet of the State Highway Right-of-Way excluding Loop 150/Chestnut Street from Perkins Street to American Legion Drive. Correlated color temperature (CCT) greater than 3,000 K is prohibited (except existing). Externally lit signs: stationary, fully shielded, bulbs/tubes not visible from R.O.W. or residences. Correlated color temperature (CCT) greater than 3,000 K is prohibited (except existing).

Sec. 14.07.007 Permanent Signs

- A. Awning/Canopy. Count toward wall-sign allowance; ground-floor only; min 8 ft clearance to sidewalk; The sign shall not exceed 1 sq ft per linear foot of awning width.
- B. Building Wall. Max area based on facade linear footage; only the primary façade width may be used for calculation. For businesses that have multiple road frontages additional signs are allowed per frontage.
 - 1) Ratio of 1.25 square feet per linear foot of primary façade width, for buildings or tenant spaces with up to fifty (50) linear feet of primary facade.
 - 2) Ratio of 1.50 square feet per linear foot of primary façade width, for buildings or tenant spaces with between fifty (50) and seventy-five (75) linear feet of primary facade.
 - 3) Ratio of 1.75 square foot per linear foot of primary façade width, for buildings or tenant spaces with greater than seventy-five (75) linear feet of primary facade.
 - 4) For buildings or tenant spaces with more than one exterior building wall with exposure to vehicular traffic, the maximum area of wall signage may be increased by 25% if the sign area is split between at least two (2) signs located on different wall exposures visible to vehicular traffic.
- C. Projecting/Marquee Signs. Max one per business with a maximum of 16 sq ft and a 9 ft minimum clearance; projecting no more than 4 ft from wall. For cinema, they may include a changeable list of movie titles and extend to up to 10 ft from the building.

- D. Suspended/Blade Signs (under canopy). Signs cannot be more than 6 sq ft not counted toward wall-sign total; 8 ft minimum clearance; mount perpendicular to facade. For businesses that have multiple road frontages additional signs are allowed per frontage.
- E. Monument/Directory/Directional/Multitenant. Allowed per sign category, number, area, and height per dimensional standards and shall include street addresses. There should be a 75 ft spacing that shall be maintained between all monument signs. For businesses that have multiple road frontages additional signs are allowed per frontage.
 - 1) For sites with one or more buildings the maximum dimensions are as follows:
 - a) Forty-eight (48) square feet of sign area, eighty (80) square feet of sign structure area and a maximum height of eight (8) feet if the speed limit of the road toward which the sign is oriented is less than forty (40) mph.
 - b) Sixty (60) square feet of sign area, one hundred twenty (120) square feet of sign structure area and a maximum height of twelve (12) feet if the speed limit of the road toward which the sign is oriented is between forty (40) and forty-nine (49) mph.
 - c) Ninety-six (96) square feet of sign area, one hundred sixty (160) square feet of sign structure area and a maximum height of sixteen (16) feet if the speed limit of the road toward which the sign is oriented is fifty (50) mph or greater.
- F. Window Signs. Max coverage = 50% of window area if the background is solid color and 100% max if the background is transparent; may be painted on glass, applied on the glass or hung just inside. For businesses that have multiple road frontages additional signs are allowed per frontage.
- G. Flags. Max pole height: 20 ft in Residential/Neighborhood Service (max flag 28 sq ft); 35 ft in other categories (max flag 40 sq ft). Max three flags per site; setbacks cannot be less than pole height.
- H. Pylon Signs. One (1) pylon sign is permitted per lot along State Highways; maximum sign face area shall not exceed 160 square feet and maximum sign structure area shall not exceed 240 square feet with a maximum height to width ratio of 4:1; maximum height shall be 20 feet, except that a pylon sign on a lot fronting SH 71 may be up to 35 feet in height; minimum spacing shall be 100 feet from any other pylon sign, measured structure-to-structure; and the sign may list multiple tenants within the maximum permitted area; additionally, a pylon sign may be permitted to serve a nonresidential lot that does not front a State Highway provided the benefitted lot is located within 1,000 feet of the State Highway right-of-way (measured in a straight line from the nearest lot line), and the pylon sign is located on private property on a lot that fronts the State Highway within 200 feet of the State Highway right-of-way and within 1,000 feet (straight-line) of the principal building or primary business entrance it advertises, and is authorized by common ownership or a recorded sign easement identifying the benefitted lot.

- I. Subdivision Entry. One per primary entrance (or per corner/median with license agreement); max 48 sq ft; max height 8 ft; masonry materials; downward/ground lighting; landscaped area = 2× sign face area with irrigation and shrubs; provide perpetual maintenance plan.

Sec. 14.07.008 Temporary Signs

- A. A-Frame/Sidewalk Signs. As allowed for businesses; portable; count/size per dimensional standards. A maximum height of 4 ft and width of 3 ft, allowing for only one sign per business or ROW frontage and it cannot obstruct the 4 ft ADA pedestrian clearance. For businesses that have multiple road frontages additional signs are allowed per frontage.
- B. Banner Signs. Maximum sign area is 48 sq ft and cannot exceed 75% of the building space upon which the sign is to be located. The maximum height is 4 ft and must have all 4 corners securely attached to the building or posts. For businesses that have multiple road frontages additional signs are allowed per frontage.
- C. Construction Site. One freestanding per street frontage (no more than 32 sq ft) and one wall sign per building (no more than 10% of facade). Display no earlier than 30 days before activity; remove within 30 days of completion or upon installation of permanent sign.
- D. Development Information. No more than 40 sq ft; quantity scaled by lots (1 per 50 lots, up to 32; additional only on very large projects); unified design and durable materials; on private property within the project, not on boundary streets; displayed from plat recordation (residential) or site plan/building permit approval (commercial) until 90% of the phase is complete.
- E. Light Pole-Mounted Banners. Limited to no more than one banner per light pole, no more than 12 sq ft in area per banner. Such banners must be approved by the appropriate electric utility company in addition to receiving a permit from the City's Development Services Department and can only be placed by the City of Bastrop departments. Banners shall not be illuminated except from the lamp of the light pole. Banners shall be maintained in good repair and replaced or removed as needed.
- F. Political. No permit needed; Political signs must comply with the Texas Election Code Chapter 259 and the Texas Local Government Code Chapter 216.
- G. Bandit Signs-Shall not exceed four (4) square feet and shall not be more than three (3) feet above the natural grade. They shall not be placed on the public right- of- way, or within the sight visibility triangle of an intersection. The sign shall be set back from the property line a minimum of five (5) feet and shall not exceed three (3) feet in height above the natural grade.

Sec. 14.07.009 Prohibited Signs/Practices

- A. New billboards, alterations to existing billboards, and other off-premise signs (incl. advertising benches) unless expressly authorized herein.
- B. Signs in or projecting over public R.O.W. (unless expressly allowed), on public poles/trees/benches/hydrants, or obstructing official traffic control.

- C. Signs that block required ingress/egress or occupy sight triangles; signs emitting sound, odor, smoke, steam, lasers, or moving imagery; tethered balloons/inflatables; unauthorized banners/pennants; unpermitted roof signs; certain pole-mounted objects used as signs.
- D. Vehicles/trailers/boats parked or displayed as signs (excludes regularly used business vehicles with permanent graphics such as mobile food vendors).

Sec. 14.07.010 Nonconforming, Nuisance, and Removal

- A. Purpose. To allow lawfully established signs that do not conform to current standards to continue, while limiting expansion of nonconformity and encouraging gradual compliance.
- B. Continuation. A lawfully erected nonconforming sign may remain, subject to this section.
- C. Prohibited acts. A nonconforming sign shall not be:
 - 1) increased in height, area, number of faces, or otherwise enlarged;
 - 2) relocated (including relocation on the same lot);
 - 3) structurally altered in a manner that it changes the sign type, or increases the degree of nonconformity.
- D. Maintenance allowed. Normal maintenance and incidental repair is permitted provided it does not increase nonconformity. Repainting, refinishing, cleaning, and changing letters/symbols on the sign face may be treated as maintenance.
- E. Damage or destruction. If a nonconforming sign is damaged or destroyed beyond the threshold established by this Code (60% of the cost of a comparable new sign at the same location), the sign shall be removed or replaced only with a conforming sign.
- F. Unsafe or unlawful signs. This section does not legalize signs that were erected unlawfully or signs that are unsafe. Such signs may be required to be removed or brought into compliance pursuant to enforcement provisions.
- G. Nonconforming signs may continue subject to this Article; alterations require compliance.
- H. Signs that are abandoned, unsafe, or an immediate hazard constitute a public nuisance.

Sec. 14.07.011 Dimensional Standards & Permissions

- A. Table of Permitted/Allowed Signs. Signs may be installed only as listed by sign category and type (A = Allowed w/o permit; P = Permit required). All unlisted sign types are prohibited.

Sign Type	P/OS	RR	SF	MU	GC	PI	IND	PDD
Permanent								
Awning/canopy	-	-	-	P	P	P	P	P
Building Wall/Band	-	-	-	P	P	P	P	P
Directional	P	-	-	P	P	P	P	P

Directory	P	-	-	P	P	P	P	P
National or Official Flags	A	A	A	A	A	A	A	A
Government	A	A	A	A	A	A	A	A
Marquee	P	-	-	P	P	P	P	P
Monument	P	-	-	P	P	P	P	P
Multitenant	-	-	-	P	P	P	P	P
Projecting	-	-	-	P	P	P	P	P
Pylon ¹	-	-	-	p ¹	p ¹	p ¹	p ¹	p ¹
Subdivision entry	P	P	P	P	P	P	P	P
Suspended/Blade	-	-	-	P	P	P	P	P
Window	-	A	A	A	A	A	A	A
Temporary								
A-Frame	A	-	-	-	A	A	A	A
Banner	P	-	-	P	P	P	P	P
Construction Site	P	P	P	P	P	P	P	P
Development Information	P	P	P	P	P	P	P	P
Light Pole-Mounted	P	-	-	P	P	P	P	P
Political	A	A	A	A	A	A	A	A
Bandit	A	A	A	A	A	A	A	A

¹Only as specified in section 14.07.007(H).

B. Not all maxima must be used; smaller signs are encouraged where context warrants.

Sec. 14.07.012 Sign Board; Administrative Relief; Variances and Appeals.

A. Authority and intent.

- 1) This Article is adopted under the City’s home-rule authority and City’s general powers of Texas Local Government Code Chapters 51 and 216, as amended, to license, regulate, control, and prohibit signs as provided by law.
- 2) This Section establishes the City’s procedures for administrative relief, appeals, and variances from the requirements of this Article. These procedures govern sign regulation relief except where state law provides mandatory procedures for specific sign actions.

B. Sign Board.

- 1) The City will designate a Sign Board for purposes of this Article.
- 2) When acting on matters under this Article, the board acts in its capacity as the Sign Board and shall apply the standards and procedures in this section.
- 3) The board shall consist of 5 regular members and 2 alternate members who shall be appointed by the mayor, confirmed by the City Council, in accordance with state law.
- 4) Members of the sign board shall regularly attend meetings and public hearings of the board and shall serve without compensation. Attendance requirements for the board members are set forth in the Bastrop Code of Ordinances, Section 1.02.002(b) for Advisory Boards.
- 5) Any vacancy of a regular member shall be filled by an alternate member only for the unexpired term of the member whose term becomes vacant.

C. Administrative relief.

- 1) Minor adjustments. The Director may approve administrative relief of up to 10% from any numeric sign standards as specifically authorized in this Article, including any stated percentage or dimensional tolerances, when the Director finds the request:
 - a) is consistent with the purpose and intent of this Article; and
 - b) is the minimum adjustment necessary due to site conditions; and
 - c) will not create a traffic safety hazard or obstruct required visibility; and
 - d) creates no additional glare or illumination; and
 - e) the sign remains compatible with district character.
- 2) Administrative relief is not a sign variance and does not authorize a sign type that is prohibited by this Article.

D. Appeals of administrative decisions.

- 1) Any person aggrieved by a written decision, interpretation, order, or determination of the Director under this Article may appeal to the Sign Board.
- 2) An appeal must be filed in writing on a City form, stating the specific grounds for appeal, not later than the 20th calendar day after the date the decision is made.
- 3) Upon receipt of a complete appeal, the Director shall transmit the record of the action appealed to the Sign Board.
- 4) An appeal stays all proceedings in furtherance of the action appealed unless the Director certifies in writing that a stay would cause imminent peril to life or property.

- 5) The Sign Board shall hold a public hearing and decide the appeal based on the record and testimony. The Sign Board may affirm, modify, or reverse the decision and may impose reasonable conditions necessary to carry out the intent of this Article and protect public safety.
- 6) The Sign Board shall render a decision not later than the 60th day after the date the appeal is filed, unless the appellant agrees in writing to an extension.

E. Sign variances.

- 1) A sign variance is required when a request for sign regulation relief exceeds the Director's administrative relief authority or seeks relief from a standard not eligible for administrative relief.
- 2) A sign variance may adjust only sign standards within this Article, including sign area, height, location, setback, separation, projection, and number, as applicable. A sign variance may also authorize a sign type that is prohibited by this Article.
- 3) Required findings. The Sign Board may grant a sign variance only upon written findings that:
 - a) special circumstances or physical conditions unique to the site create a practical difficulty in complying with this Article;
 - b) the practical difficulty is not self-created and is not based solely on financial considerations;
 - c) the variance is the minimum relief necessary to allow reasonable sign opportunity consistent with the purpose and intent of this Article; or
 - d) the variance will not create a traffic safety hazard, obstruct required visibility, or materially impair adjacent property.
- 4) Conditions and duration. The Sign Board may impose conditions, including design, placement, illumination limits, and time limits, to ensure compatibility and safety. A granted sign variance shall expire if the related sign permit is not obtained within the time established by the Sign Board or, if no time is established, within one (1) year from the date of approval.

F. Master Sign Plan:

- 1) A Master Sign Plan is a comprehensive document containing specific regulations for an entire Project's Signs. Master Sign Plans are required for Planned Development Districts, Master Planned Developments, development agreements or in the case where a Project applicant is seeking several variances to the Signs section.
 - a) Master Sign Plans for areas with a multi-unit complex are highly encouraged to meet the unique needs of each multiunit complex.

- b) All owners, tenants, sub-tenants and purchasers of individual units within the Development shall comply with the approved Master Sign Plan.
- c) Master Sign Plans are not appropriate for a single tenant to increase the amount or size of signage.
- d) A change in Sign Types cannot be approved if not allowed in the base Zoning District for the site.
- e) Cannot include changes to non-conforming signs.

G. Approval of Master Sign Plans

- 1) A Responsible Party that seeks approval of a Master Sign Plan must file a request for a Master Sign Plan with the Sign Administrator along with a Sign permit fee, as stated in the City's most recent master fee schedule. The Sign Administrator will indicate what documentation the Responsible Party must provide in support of the request.
- 2) Once the necessary documentation has been provided to the Sign Administrator, the Sign Board will deny or approve the Master Sign Plan, with or without conditions.
- 3) If the Responsible Party disagrees with a decision of the Sign Administrator to deny a Master Sign Plan, or disagrees with the conditions placed on a Master Sign Plan by the Sign Administrator, the Responsible Party may submit a written request that the City Council review the Master Sign Plan request, the supporting documents, and the Sign Administrator's decision. The Sign Board can affirm, reverse, or modify the decision of the Sign Administrator.
- 4) The Sign Board has final authority to approve a Master Sign Plan or conditions on a Master Sign Plan.
- 5) A Master Sign Plan ordinance can modify Variance procedures for its specific property.

H. Nothing in this section waives compliance with any mandatory procedures or requirements imposed by Texas Local Government Code Chapter 216 for specific actions affecting signs, when applicable.

Sec. 14.07.013 Murals as Public Art

A. Purpose. The purpose of this Section is to encourage murals as public art that contribute to community character and placemaking, while ensuring that wall graphics used for advertising are regulated as signs.

B. Applicability

- 1) This Section applies to any mural, wall graphic, or painted image installed on the exterior of a building, wall, fence, or similar surface that is visible from a public street, sidewalk, alley, park, or other public place.
- 2) Murals that qualify as Public Art Murals under this Section are not signs and are exempt from sign area calculations, sign type limitations, and sign permit requirements.

- 3) Wall graphics that meet the definition of a Commercial Wall Graphic are signs and must comply with this Code's wall sign standards and permitting requirements.
- C. Classification
- 1) Presumption. Murals are presumed to be Public Art Murals unless they include a Commercial Message or otherwise meet the definition of a Commercial Wall Graphic.
 - 2) Mixed content. If a mural contains both artistic elements and a Commercial Message, the mural is classified as a Commercial Wall Graphic.
 - 3) Determination. The Development Services Director (or designee) shall make classification determinations using the definitions in Subsection C. The Director may require the applicant to provide a scaled rendering to verify whether a Commercial Message is present.
- D. Approval and Permits
- 1) Public Art Mural approval.
 - a) A Public Art Mural requires a Mural Permit issued administratively by the Development Services Director prior to installation.
 - b) If the mural is on a property or structure subject to the Historic District regulations or local landmark review, the mural also requires a Certificate of Appropriateness, and the Mural Permit shall not be issued until that approval is granted.
 - 2) Commercial Wall Graphic approval. A Commercial Wall Graphic requires a sign permit and must comply with all applicable wall sign standards, including sign area limitations.
 - 3) Building and fire code compliance. Issuance of a Mural Permit does not waive compliance with applicable building, fire, and property maintenance codes. If mural installation involves structural attachment, electrical work, or changes to exterior materials, all required permits must be obtained.
- E. Submittal requirements for a Public Art Mural. An application for a Mural Permit shall include:
- 1) Written authorization from the property owner.
 - 2) A scaled elevation or photograph of the wall with the proposed mural superimposed, showing location, dimensions, and the Mural Area.
 - 3) A description of materials and methods (paint type, sealants, mounting method if applicable).
 - 4) Colors and renderings sufficient to evaluate compatibility with the building and surroundings.
 - 5) A maintenance plan describing cleaning, touch ups, and fading mitigation.
 - 6) A removal plan stating how the surface will be restored if the mural is removed or replaced.
 - 7) For murals within any historic review area, documentation required by the applicable COA process.
- F. Standards for Public Art Mural. A Public Art Mural shall comply with the following:
- 1) No commercial message. The mural shall not include a Commercial Message as defined in Subsection C.
 - 2) Any reference to the following is strictly prohibited.

- a) Obscenity. A mural shall not depict or display obscene material as defined by Texas Penal Code §43.21.
 - b) True threats. A mural shall not include a true threat, meaning a statement or depiction that communicates a serious expression of intent to commit unlawful violence against a particular individual or group.
 - c) Incitement. A mural shall not be directed to inciting or producing imminent lawless action and likely to incite or produce such action.
 - d) Other content. Murals shall otherwise be reviewed and regulated only under the objective standards of this Code (for example location, lighting, traffic safety, and maintenance).
- 3) Location.
- a) The mural shall be located on a lawful structure and shall not be painted on doors, operable windows, or glazed areas intended for visibility or emergency egress.
 - b) The mural shall not be located in a manner that obscures required address numbers, required safety signage, or required building identification.
- 4) Traffic safety. The mural shall not be installed on a surface that could be reasonably construed as a traffic control device or that creates a documented traffic safety hazard (for example, within a sight visibility triangle at a driveway or intersection).
- 5) Lighting. If illuminated, illumination shall be steady, shielded, and directed at the mural face to prevent glare and light trespass. Flashing, moving, or intermittently changing lights are prohibited. Illumination shall be subject to the City's Outdoor Lighting Ordinance under Section 14.04.003 of this Code.
- 6) Digital and projection. A Public Art Mural shall not be an electronic display, dynamic display, or projected image.
- 7) Maintenance. The mural and wall surface shall be maintained in good condition. Peeling, chipping, fading, cracking, or defacement that materially degrades the mural shall be repaired or removed in accordance with Subsection G.
- G. Alteration, defacement, and removal
- 1) Alterations. Repainting, replacing, or altering more than 25 percent of the Mural Area requires a new Mural Permit and, if applicable, a new COA.
 - 2) Deterioration. If the City determines that a mural is deteriorated or defaced to the extent that it constitutes a property maintenance issue, the City may issue a notice requiring repair or removal within a specified timeframe.
 - 3) Conversion to signage. If a Commercial Message is added to an approved Public Art Mural, the mural becomes a Commercial Wall Graphic and must either (a) obtain a sign permit and comply with sign standards, or (b) remove the Commercial Message and restore compliance, within the timeframe stated in the City's notice.

H. Relationship to other regulations

- 1) Nothing in this Section limits enforcement of other applicable codes, including historic preservation regulations, building and fire codes, and property maintenance standards.
- 2) Where this Section conflicts with another provision of this Code, the more restrictive provision applies.

ARTICLE 14.08 CODE ENFORCEMENT & NONCONFORMITIES

Sec. 14.08.001 Authority, Purpose, and Applicability

- A. Authority. Adopted under the City's home-rule powers and municipal zoning authority.
- B. Purpose. Establish zoning-specific standards for (1) recognition and administration of lawful nonconformities and (2) zoning enforcement tools limited to this Chapter (notice of violation and stop-work orders).
- C. Applicability. This Article applies to zoning matters within the City limits. Nothing herein extends zoning to the ETJ.
- D. No Conflict with General Code. Where this Article addresses processes also covered by the City's general code-enforcement provisions, those citywide provisions govern procedure; this Article governs substantive zoning compliance.
- E. Cross-References.
 - 1) Zoning Board of Adjustment (ZBA) appeals and procedures: see Article 14.12, Zoning Board of Adjustments.
 - 2) Certificates of Occupancy (CO) actions (withholding/suspension): see Article 14.13 (Administration & Procedures).
 - 3) Vested Rights: See Chapter 1.20 Uniformity of Requirements.

Sec. 14.08.002 Administration

- A. Director. The Director of Development Services (or designee) administers this Article and may issue zoning notices of violation and zoning stop-work orders under this Chapter.
- B. Coordination. The Director shall coordinate with the Building Official and Code Enforcement to avoid duplicative/conflicting orders.
- C. Appeals. Appeals of administrative decisions under this Article are to the ZBA, Article 14.12; filing does not authorize continued violation unless the ZBA stays enforcement under its rules.

Sec. 14.08.003 Zoning Notice of Violation (NOV)

- A. Use. An NOV may be issued where land, structures, or uses do not conform to this Chapter or to conditions of a zoning approval.
- B. Content. The NOV shall state: (1) property identification; (2) specific zoning provisions/conditions alleged violated; (3) facts observed; (4) required corrective action(s); and (5) a reasonable correction deadline.
- C. Service. Serve to the owner and, where applicable, occupant/permit holder by a standard method recognized in the City's general code-enforcement chapter.
- D. Reinspection. After the deadline, the Director reinspects and may (1) close the case; (2) extend time for good cause; or (3) escalate (e.g., stop-work, referral for further enforcement consistent with City code).

- E. Consistency Clause. NOV procedures here are intended to complement—not supersede—any more detailed service or timing rules in the City’s general code-enforcement chapter.

Sec. 14.08.004 Zoning Stop-Work Orders

- A. Triggers. The Director may issue a zoning stop-work order when work or use:
 - 1) lacks required zoning approval;
 - 2) violates a condition of zoning approval; or
 - 3) materially departs from approved plans under this Chapter.
- B. Form and Posting. The order shall be in writing, identify the violation, and be posted on-site and served to the owner/permit holder.
- C. Effect. All development activity subject to this Chapter shall cease only to the extent necessary to remedy the zoning violation identified; life-safety work may continue as authorized by the Building Official.
- D. Release. The Director shall lift the order upon verified correction or upon ZBA relief.
- E. Appeal. Appeal is to the ZBA, Article 14.12. Filing an appeal does not stay a stop-work order unless the ZBA grants a stay under its rules.

Sec. 14.08.005 Nonconformities—General

- A. Types.
 - 1) Nonconforming Use: Lawful use established before a change in zoning regulations that now prohibits the use.
 - 2) Nonconforming Structure: Lawful structure that no longer meets dimensional/design standards.
 - 3) Nonconforming Lot: Lawfully created lot that no longer meets current lot standards.
- B. Legal vs. Illegal. Only lawfully established situations are eligible for nonconforming status. Illegal uses/structures must be brought into compliance.
- C. Continuation. Lawful nonconformities may continue subject to this Section and applicable state law.
- D. Transfer. Nonconforming status runs with the land.
- E. Maintenance/Repair. Routine maintenance and like-kind repairs that do not increase the degree of nonconformity are permitted.
- F. Verification. The Director may issue a written Verification of Nonconforming Status upon satisfactory evidence of lawful establishment and continuity.

Sec. 14.08.006 Nonconforming Uses

- A. No Expansion. A nonconforming use shall not expand in area, intensity, or to other portions of a site or structure, except: (1) as required to meet life-safety codes; or (2) as expressly authorized by the ZBA, Article 14.12.
- B. Change of Use. A nonconforming use may only change to a conforming use. Once changed to a conforming use, nonconforming rights are lost.
- C. Discontinuance / Abandonment.

- 1) Six-Month Presumption. Discontinuance for six (6) consecutive months creates a rebuttable presumption of abandonment.
 - 2) Eighteen-Month Bar. Discontinuance for eighteen (18) consecutive months constitutes prima facie abandonment; nonconforming rights terminate.
 - 3) Commencement. Discontinuance is measured from the actual date the use ceased.
- D. City-Required Cessation. The City will not require cessation of a lawful nonconforming use except as permitted by applicable state law. Any required procedures (including notice and remedies) shall be administered under the City's Administration & Procedures article or other applicable chapter, not in this Article.

Sec. 14.08.007 Nonconforming Structures

- A. Alterations. Alterations that reduce noncompliance are allowed. Alterations that do not increase the degree of noncompliance may be approved by the Director.
- B. Additions/Enlargements. Additions that increase the degree of noncompliance require relief from the ZBA where authorized.
- C. Safety/Code Work. Improvements necessary to comply with adopted building, fire, flood, or accessibility codes may be made.

Sec. 14.08.008 Restoration After Casualty

- A. Right to Rebuild. If a structure containing a nonconforming use or a nonconforming structure is damaged or destroyed by fire, weather, or other casualty, it may be rebuilt or repaired if permits are sought and work commences within eighteen (18) months of the damage.
- B. Permits. The permits must be applied for within (6) months of the damage occurring. Time period may be extended by the Director for reasonable accommodation.
- C. Extent. Rebuilding shall not increase the degree of nonconformity except as approved by the ZBA where authorized.
- D. Other Codes. All reconstruction must comply with current health, safety, and building codes.

Sec. 14.08.009 Nonconforming Lots (Lots of Record)

- A. Development Permitted. A lawfully created lot that does not meet current dimensional standards may be used for any permitted use if all other applicable standards are met or appropriate relief is granted.
- B. Deemed Conformity—Historic Plats. A vacant lot legally platted before adoption of the Bastrop Development Code is deemed conforming for purposes of one principal building/use, subject to all other applicable standards.
- C. Lot Consolidation Encouraged. Where feasible, consolidation or replatting to reduce nonconformities is encouraged.

Sec. 14.08.010 Redevelopment and Expansion of Nonconforming Sites

- A. Purpose. The purpose of this Section is to:

- 1) Allow reasonable reinvestment in sites with lawful nonconforming conditions;
 - 2) Limit the expansion of nonconforming uses, structures, and site features; and
 - 3) Require reasonable, proportional upgrades toward current standards when redevelopment or expansion occurs.
- B. Applicability.
- 1) This Section applies to any site with one or more lawful nonconforming uses, structures, or site features (including parking, landscaping, access, or frontage improvements) when a site plan or building permit is required for redevelopment, expansion, or change of use.
 - 2) This Section supplements the general rules for nonconforming uses, structures, and lots in Sections 14.08.005–14.08.009.
- C. Limitations on Expansion of Nonconformities.
- 1) A nonconforming use may not expand in area or intensity except as allowed in Section 14.08.006.
 - 2) A nonconforming structure may not be expanded or altered in a way that increases the degree of noncompliance except as allowed in Section 14.08.007 or by relief granted by the Zoning Board of Adjustment.
 - 3) Site modifications associated with redevelopment or expansion shall not:
 - a) Extend an existing encroachment into a setback or buffer;
 - b) Reduce an existing parking, landscaping, screening, or access deficiency below its current level;
or
 - c) Create new nonconformities.
- D. Redevelopment and Expansion Standards for Nonconforming Sites.
- 1) When redevelopment, expansion, or change of use occurs on a nonconforming site, the following upgrades shall be required to the extent reasonably practicable and proportionate to the scope of work, as determined by the Director:
 - a) Site Disturbance of 25% or More of Total Site Area. When grading, clearing, or redevelopment disturbs twenty-five percent (25%) or more of the total site area:
 - (1) Frontage improvements along the site’s public street frontage (including sidewalks, ADA ramps, street trees, and street lighting) shall be brought into compliance with current standards along the disturbed frontage; and
 - (2) Any parking areas that are reconstructed or restriped as part of the project shall comply with current standards for layout, interior landscaping, and bicycle parking.

- b) Increase in Gross Floor Area of 25% or More. When the total gross floor area on the site has increased by twenty-five percent (25%) or more since original approval:
 - (1) Parking, loading, stacking, and access spacing shall be evaluated under current standards; and
 - (2) Corrective improvements shall be required where feasible to address documented deficiencies (such as unsafe access, inadequate loading, or substantial parking shortages).
 - c) Parking Expansion of 25% or More, or New Parking Field. When on-site parking capacity increases by twenty-five percent (25%) or more, or a new parking lot or parking field is constructed:
 - (1) All new or expanded parking areas shall comply with current standards for design, interior landscaping, shade, and lighting; and
 - (2) The Director may require reasonable tie-in improvements (circulation, screening, or connections) between existing and new parking areas to ensure safe and functional operation.
 - d) Change of Use Increasing Trips or Parking Demand by 20% or More. When a change of use increases estimated peak-hour traffic or parking demand by twenty percent (20%) or more, based on accepted traffic or parking analysis methods:
 - (1) Site access, cross-access, and internal circulation shall be reviewed for consistency with current standards; and
 - (2) Proportionate mitigation (such as driveway consolidation, cross-access easements, internal drive connections, or striping/signage changes) may be required to address safety and operational concerns.
 - e) Documented Safety Hazards. When a nonconforming condition on the site is documented by the City as a safety hazard (such as deficient sight distance, inadequate fire apparatus access, or high-crash driveway spacing), the improvements necessary to eliminate or materially reduce the hazard shall be required as a condition of site plan or permit approval.
 - f) Overlay and Special Districts. For nonconforming sites located within an adopted overlay district or special district, any redevelopment or expansion shall comply with applicable overlay standards for the portion of the site affected by the project. Where overlay provisions require site-wide compliance (such as Wildland-Urban Interface emergency access or water supply standards), such provisions shall apply to the entire site.
- E. Administrative Determination. The Director shall determine the extent of required upgrades under this Section based on site conditions, physical feasibility, and the proportional relationship between the cost of

compliance and the scope of the proposed work, consistent with applicable Texas law governing proportionality and nonconforming uses and structures.

Sec. 14.08.011 Manufactured Home Communities (Special Rule)

- A. Continuation & Replacement. Nonconforming manufactured home communities and lots are protected as provided by applicable state law. A manufactured home on a nonconforming lot in such a community may be replaced if installed in compliance with state/federal installation standards and this Chapter’s nonconformity limits.

Sec. 14.08.012 Violations; Relationship to Other Enforcement

- A. Zoning Violations. Use, occupancy, or development contrary to this Chapter or to a condition of zoning approval is a zoning violation.
- B. Enforcement. Zoning NOVs and zoning stop-work orders are governed by this Article; all other enforcement tools, penalties, or prosecution are governed by the City’s general code-enforcement provisions and are not created or expanded by this Article.
 - 1) General penalty for violations of the zoning code shall follow the procedures and fines as specified in Section 1.01.009 of the Bastrop Code of Ordinances. Each day that a violation continues shall be deemed a separate and distinct offense.
- C. Remedies Cumulative. The City may pursue available remedies as provided elsewhere in the City Code; nothing herein authorizes enforcement outside zoning matters.

ARTICLE 14.09 HISTORIC PRESERVATION ORDINANCE

Sec. 14.09.001 Purpose and Intent.

- A. The City Council declares that the protection, enhancement, and preservation of sites, landmarks, and districts of historical, architectural, and cultural significance is a matter of public policy and essential to promoting the economic, educational, cultural, and general welfare of the community. The City recognizes that its character is shaped by a unique convergence of time, place, and people, resulting in valuable historic and cultural resources that reflect the heritage and identity of its citizens. This article is enacted to:
- 1) Protect and enhance the landmarks, which represent distinctive elements of the City's historic, architectural, and cultural heritage;
 - 2) Foster civic pride in the accomplishments of the past;
 - 3) Protect and enhance the City's attractiveness to visitors, thereby supporting and stimulating the economy;
 - 4) Insure the harmonious, orderly, and efficient growth and Development of the City;
 - 5) Promote economic prosperity and welfare of the community by encouraging the most appropriate use of such property within the City;
 - 6) Encourage stabilization, restoration, and improvements of such properties and their values.

Sec. 14.09.002 Historic Landmark Commission.

- A. The Commission shall consist of seven (7) members, residents of the City, to be appointed by the mayor with approval by the City Council as follows; every effort will be made to find professionals who meet the criteria below:
- 1) One shall be an architect, city planner, or representative of a design profession;
 - 2) One shall be a representative elected by the Bastrop County Historical Society;
 - 3) One shall be a licensed real estate professional;
 - 4) One shall be an owner of a historic Commercial Structure or property;
 - 5) One shall be an owner of an historic Residential Structure or property;
 - 6) One shall be a member from the Planning & Zoning Commission;
 - 7) One shall be a general resident of the City.
- B. All Historic Landmark Commission members, regardless of background, shall have a known and demonstrated interest, competence, or knowledge in historic Preservation within the City.
- C. Historic Landmark Commission members shall serve for a term of 3 years, except for the member who is serving on the Historic Landmark Commission as the Planning & Zoning Commission representative, and that member shall serve for a term that is concurrent with that member's Planning & Zoning Commission term.
- D. Attendance requirements for the Historic Landmark Commission members are set forth in Section 1.02.002(b) of the Code of Ordinances.

- E. The commission shall be empowered to:
- 1) Approve or disapprove Certificates of Appropriateness, Demolition or Removal of historic Structures, and economic hardship applications.
 - 2) Conduct surveys and maintain an Inventory of significant historic, architectural, and cultural landmarks.
 - 3) Make recommendations to the City Council on the designation of historic landmarks, Historic Districts, Contributing and non-Contributing Structures.
 - 4) Make recommendations for properties to the National Register of Historic Places.
 - 5) Increase public awareness of the value of historic, cultural, and architectural Preservation by developing and participating in public education programs.
 - 6) To assist the City Council in the adoption of Design Guidelines for the exteriors of historic landmarks, properties located inside of Historic Districts, and Contributing and non- Contributing Structures, to address architectural and general design elements of Structures, including acceptable materials for Construction; appropriate architectural character, scale, and detail; acceptable appurtenances or additions to new or existing Structures; and acceptable textures and ornamentation.
 - 7) Prepare and submit annually to the City Council a report summarizing the work completed during the previous year.
 - 8) To perform any other functions requested by City Council.
- F. The Historic Landmark Commission shall meet at least monthly, if business is at hand. Special meetings may be called at any time by the Chair, or on the written request of any two commission members.

Sec. 14.09.003 Appointment of Historic Preservation Officer.

- A. The City's Director of Planning & Development or other City staff designated by the City Manager shall serve as Historic Preservation Officer. This officer shall have as a principal duty the administration of this article and the coordination of the City's various efforts and programs that further historic Preservation.

Sec. 14.09.004 Categories of Preservation.

- A. Establishment of Preservation. There shall be two categories of Preservation for historically, culturally, architecturally or archaeologically significant properties in the City, as follows:
- 1) Historic landmarks;
 - 2) Local Historic Districts, which may contain historic landmarks and Contributing Structures or Sites; and non-Contributing Structures or Sites.
- B. Criteria for Historic Landmark Status
- 1) State and National Designations. A Structure or Site that is designated as a Recorded Texas Historic Landmark, a State Antiquities Landmark, or is listed on the National Register of Historic Places qualifies for consideration as a local Historic Landmark. Such state or national designation does not, by itself, establish local designation. A Structure or Site shall be considered a local Historic Landmark only after designation through the local process in Sec. 14.09.005.

- 2) City Designation. The City may initiate designation of a Structure or Site as a local Historic Landmark if it is generally at least fifty (50) years old, has maintained its historic character, and meets one or more of the criteria set out below. Any designation under this subsection must be made through the local designation process in Sec. 14.09.005.
 - a) Is associated with important events that have contributed significantly to the broad pattern of our history.
 - b) Is associated with the lives of persons significant in our past;
 - c) Embodies the distinctive characteristics of a type, period, or method of construction; or represents the work of a master; or possess high artistic values; or represents a significant and distinguishable entity whose components may lack individual distinction.
 - d) Have yielded, or may be likely to yield, information important to our history.

Sec. 14.09.005 Process for Designation of Historic Landmarks.

- A. Properties already listed as a Recorded Texas Historic Landmark or State Antiquities Landmark, or already included on the National Register of Historic Places, are eligible to be designated as a local Historic Landmark in the City of Bastrop, but must go through the process under this Section to be designated as a Local Historic Landmark and be eligible for Incentives under Section 14.09.013.
- B. Property owners may apply for local Historic Landmark designation, and the City may also initiate designation. Owners of property being considered for designation as a Historic Landmark shall be notified prior to the Historic Landmark Commission hearing on the recommended designation. The Historic Landmark Commission shall conduct a public hearing and provide written notice to each owner of real property within 200 feet at least 10 days before the hearing date.
- C. After consideration by the Historic Landmark Commission, a recommendation regarding designations shall be submitted to the City Council to consider the designations of a Historic Landmark. The adoption of the landmark shall be through a resolution.
- D. Upon designation of a Historic Landmark, the City Council shall cause the designation to be noted as follows:
 - 1) Recorded in the official real property records of Bastrop County.
 - 2) Designated on the historic resource map of the City.
 - 3) Provide the property owner with a plaque and require the installation indicating the designation of the landmark as a City Historic Landmark.

Sec. 14.09.006 Process for Removal of Historic Landmark Designation.

- A. Designated historic landmarks shall retain such designation until such time as the City Council, upon receipt of an Application from the owner, approves the withdrawal. The procedures for a Removal of designation of a Historic Landmark shall follow the same process as the designation process.
- B. Criteria for Approving Removal:

- 1) The original criteria that was met to receive the designation is no longer applicable for reasons not attributable to the acts or omissions of the owner or occupant.
- 2) The Site or Structure has been rendered unreasonably irreparably altered by an Act of God.
- 3) The required majority for City Council approval for Removal of designation shall be two-thirds of the full membership.

Sec. 14.09.007 Criteria for Creation of Historic Districts.

- A. An area of the City may be considered for designation as a Historic District if it:
- 1) Contains properties and an environmental setting which meet one or more of the criteria for designation of a Historic Landmark; or,
 - 2) Constitutes a distinct section of the City that possesses a unique historical, architectural, archeological or cultural significance.

Sec. 14.09.008 Process for the Designation of Local Historic District.

- A. These provisions pertaining to the designation of local Historic Districts constitute a part of the official Zoning Map of the City.
- B. Upon recommendation of the Historic Landmark Commission and the Planning & Zoning Commission, the City Council may establish, after following all required legal procedures, one or more Historic Districts. The Historic Landmark Commission shall prepare, or cause to be prepared, and adopt, Design Guidelines for each individual district, including Standards for new and/or Infill Construction. If there is more than one district, and the Historic Landmark Commission finds that Design Guidelines for one district are appropriate for another district, they may adopt the same guidelines.
- 1) Requirement for approval by three-fourths of Council. If an owner of property in a proposed historic district files a written statement protesting the inclusion of the owner's property in the historic district, a separate affirmative vote of three-fourths of all members of the council is required to include the protesting owner's property in the historic district.
- C. An Inventory of all Contributing and non-Contributing Structures located within a Historic District to be prepared and the record of the status of each Structure within each Historic District shall be maintained in City records.
- D. Owners of property located within an area considered for designation as a local Historic District shall be notified prior to the public hearing(s) on the recommended designation. The adoption of a local district will be processed according to the same procedures required for a zoning amendment. At the public hearing(s), owners, interested parties, and technical experts may present testimony or documentary evidence that will become part of a record regarding the historic, architectural, or cultural importance of the proposed local Historic District.
- E. Upon designation of a local historic district, the City Council shall cause the designation to be recorded as follows:

- 1) Recorded in the official real property records of Bastrop County,
 - 2) Designated on the historic resource map of the City.
- F. Designated Historic Districts shall retain such designation until such time as the City Council, upon receipt of an Application and formal request made by at least 51% of the owners of real property located within the Historic District petitions for Removal. The procedures for a Removal of designation of a local Historic District shall follow the same process as the designation process.
- 1) Criteria for approving Removal:
 - a) The original criteria that was met to receive the designation is no longer applicable for reasons not attributable to the acts or omissions of the owner or occupant.
 - b) The site or structure has been rendered unreasonably irreparably altered by an Act of God.
- G. The required majority for City Council approval for Removal of designation shall be 2/3 of the full membership.
- H. Any existing Structure or Site designated as a significant landmark or a Historic Landmark under Ordinance No. 2007-30 are specifically saved from repeal and shall retain such designation until such time that those designated landmarks are redesignated in accordance with the processes and procedures under this article. As soon as practical following adoption of this article, the City shall begin the process to designate any landmarks deemed appropriate for consideration as historic landmarks in accordance with the processes and procedures contained within this article.

Sec. 14.09.009 Relationship of Designations to Zoning.

- A. If there is any conflict between this Article or the Design Guidelines adopted by the Historic Landmark Commission, and any provision of the underlying zoning district, the most restrictive regulation shall apply.
- B. If there is any conflict between the provisions of this section and any other provision of the underlying zoning district, the most restrictive regulation shall apply, in the absence of a specific directive to the contrary.

Sec. 14.09.010 Certificate of Appropriateness.

- A. Requirement for Certificate of Appropriateness
 - 1) No person, firm, corporation, or organization shall undertake any Project involving the construction, reconstruction, alteration, restoration, rehabilitation, relocation, or demolition of any local, state, or national Historic Landmark—or any structure, site, or sign within a designated Historic District—without first obtaining a Certificate of Appropriateness.
 - 2) A Certificate of Appropriateness is also required before making any material change to exterior architectural features or structural elements that are visible from the public right-of-way and that affect the appearance, character, or visual cohesion of any such Landmark, structure, or site.
- B. Certificate of Appropriateness Exemptions
 - 1) Ordinary Maintenance, meaning activities relating to a property that would be considered ordinary or common for maintaining the property, such as

- a) Repair using the same material and design as the original and does not require structural modifications;
 - b) Exterior painting for maintenance, provided that (i) previously unpainted brick is not painted, and (ii) the work does not change the existing exterior color;
 - c) Reroofing, using the same type;
 - d) Replacement blade signs; or
 - e) Repair of sidewalks and driveways.
- 2) Interior Construction or Alterations do not alter the exterior wall of the Building.
- 3) New, modifications or Removal of existing awnings, canopies, exterior paint color or exterior Lighting that are attached to a residential structure provided the Alterations do not alter the exterior wall of a Building designated as a Historic Landmark.
- 4) Demolition of a Building or Structure that the Building Official has declared a dangerous Structure per the Building Code, or determined that Demolition is necessary for the preservation of the public health, safety and welfare.
- a) Should the Building Official declare a Building a dangerous Structure or determine that Demolition is necessary for the preservation of public health, safety and welfare, the Building Official shall coordinate with the Historic Preservation Officer and property owner to identify historic and significant architectural features that are unique to the Building or Structure, era or district and that may be salvaged.
 - b) The Historic Preservation Officer shall create a record of the Building or Structure to be demolished through archival-quality photo- documentation, drawings, and other information similar to those required by the Historic American Buildings Survey. The list of identified historic and significant architectural features to be salvaged shall also be made part of this record.
- 5) New fence, railing or wall that is consistent with the Historic District's characteristics and applicable guidelines.
- 6) Site landscape Alterations and other hardscape features provided that these do not alter a Building or Structure designated as a Historic Landmark or that is a Contributing historic Structure to the Historic District.
- 7) Replacement blade signs on an existing mount, where all other applicable sign codes are met.
- C. Certificate of Appropriateness Application Procedure
- 1) When a Certificate of Appropriateness is required, no work can begin before the Historic Landmark Commission has first issued a Certificate of Appropriateness. The Certificate of Appropriateness shall be in addition to and not in lieu of any permits required (i.e. Building, Sign, alcohol, etc.). The Building

Official cannot approve any application for a Sign or building permit to a Structure and/or Site that requires, but does not have a Certificate of Appropriateness.

- 2) The owner or owner's agent shall file an Application, as provided by the City, for such a certificate.

The Application shall contain at a minimum:

- a) Application fee as established in the Master Fee Schedule;
- b) Contact information for the Applicant and/or owner;
- c) A detailed description of all proposed work;
- d) Location and photographs of existing conditions;
- e) Elevation drawings, photographs, or illustrations of proposed changes;
- f) Samples of materials to be used;
- g) If the proposal includes Signs or lettering, a scale drawing showing the type of lettering to be used, all dimensions and colors, a description of materials to be used, method of illumination (if any), and a plan showing the Sign's location on the property;
- h) Any other information that the City may deem necessary in order to visualize the proposed work; and
- i) The Historic Preservation Officer shall review the submission and determine if the Application is complete. If the Application does not meet the requirements to be approved administratively, the Application will be forward to the Historic Landmark Commission for consideration at their next available meeting agenda.

D. Administrative Approval of a Certificate of Appropriateness

- 1) Certificate of Appropriateness may qualify for Administrative Approval by the Historic Preservation Officer if the proposed Project meets all of the following conditions:
 - a) The property is not located in a national Historic District;
 - b) All of the material Standards identified in the design guidelines as adopted by the Historic Landmark Commission are met;
 - c) The proposed Structure or Site is not designated as a local, state, or national Historic Landmark.
 - d) Exterior repainting that changes the existing exterior color, provided that (i) previously unpainted brick is not painted, and (ii) the proposed color is consistent with the Design Guidelines' approved color palette.
- 2) The Historic Preservation Officer may elect to present a Certificate of Appropriateness to the Historic Landmark Commission for review and consideration.
- 3) If the Historic Preservation Officer does not approve a Certificate of Appropriateness, the Application may be forwarded to the Historic Landmark Commission for review and consideration at the request of the Applicant.

E. Historic Landmark Commission Approval of Certificate of Appropriateness

- 1) The Commission shall review an application for a Certificate of Appropriateness at a regularly scheduled or special meeting within 45 day from the date the application is deemed administratively complete for review, at which time an opportunity will be provided for the applicant to be heard. The Historic Landmark Commission shall approve, deny, or approve with conditions or modifications the permit, within 30 days after the review meeting, provided however, both review and action may occur at the same meeting. In the event the Historic Landmark Commission does not act within 60 days from the date the application is deemed administratively complete for review, a permit will be deemed approved.
- 2) All decisions of the Historic Landmark Commission shall be in writing. The Historic Landmark Commission's decision shall state its findings pertaining to the approval, denial, or modification of the Application. A copy shall be provided to the Applicant and a copy shall be maintained in the files of the Development Services Department and distributed to other appropriate City departments.
- 3) An Applicant for a Certificate of Appropriateness who is dissatisfied with the action of the Historic Landmark Commission relating to the issuance or denial of a Certificate of Appropriateness shall have the right to Appeal the determination to the City Council. The Applicant has 15 calendar days from date of the Historic Landmark Commission action to file for the Appeal. The Appeal request will be placed on the next available City Council agenda. To be considered, the Appeal shall set forth in writing the grounds for such Appeal and shall provide the City with any pertinent evidence and all related documentation related to the Appeal. The City Council shall use the adopted approval criteria for the Appeal review.
- 4) A Certificate of Appropriateness shall expire two years from the date of approval if the proposed scope of work has not been completed. If the building permit for approved work has been issued, the Certificate of Appropriateness will expire two years from the permit issue date. The Commission, upon determination of a reasonable need, may authorize one extension of an additional six months to obtain a building permit for the work in which the Certificate of Appropriateness was approved upon showing of just cause by the Applicant.

F. Criteria for Approval of Certificate of Appropriateness (COA)

- 1) In considering an Application for a Certificate of Appropriateness (COA), the Historic Landmark Commission shall be guided by any locally adopted design standards, and where applicable, the following from the Secretary of the Interior's Standards for Rehabilitation of Historic Buildings. Any adopted design standards and Secretary of the Interior's Standards shall be made to the property owners of historic landmarks.
 - a) Every reasonable effort shall be made to adapt the property in a manner which requires minimal Alteration of the Building, Structure, object, or Site and its environment.

- b) The distinguishing original qualities or character of a Building, Structure, object, or Site and its environment shall not be destroyed. The Removal or alteration of any historic material or distinctive architectural features should be avoided when possible.
- c) All buildings, Structures, objects, and Sites shall be recognized as products of their own time. Alterations that have no historical basis and which seek to create an earlier or later appearance shall be discouraged.
- d) Changes that may have taken place in the course of time are evidence of the history and Development of a Building, Structure, object, or Site and its environment. These changes may have acquired significance in their own right, and this significance shall be recognized and respected.
- e) Distinctive stylistic features or examples of skilled craftsmanship which characterize, a Building, Structure, object, or Site shall be kept to the greatest extent practical.
- f) Deteriorated architectural features shall be repaired rather than replaced, wherever possible. In the event replacement is necessary, the new material should reflect the material being replaced in composition, design, color, texture, and other visual qualities. Repair or replacement of missing architectural features should be based on accurate duplications of features, substantiated by historical, physical, or pictorial evidence rather than on conjectural designs or the availability of different architectural elements from other Building or Structures.
- g) The surface cleaning of structures shall be undertaken with the gentlest means possible. Sandblasting and other cleaning methods that will damage the historic building materials shall not be undertaken.
- h) For building materials, architecture standards, architectural details, massing for a variety of building types, see the design guidelines.
- i) Every reasonable effort shall be made to protect and preserve archeological resources affected by, or adjacent to, any Project.
- j) Contemporary design for Alterations and Additions to existing properties shall not be discouraged when such Alterations and Additions do not destroy significant historical, architectural, or cultural material, and such design is compatible with the size, color, material, and character of the property, neighborhood, or environment.
- k) Wherever possible, new Additions or Alterations to buildings, Structures, objects, or Sites shall be done in such a manner that if such Additions or Alterations were to be removed in the future, the essential form and integrity of the Building, Structure, object, or Site would be unimpaired.

G. Consideration of Previously Denied Applications

- 1) A new Application for a Certificate of Appropriateness for a structure or Site that was previously denied a similar Certificate of Appropriateness shall not be considered if the Historic Landmark Commission or the City Council, on appeal, for the structure or Site within 1 year from the date of the final decision. If there has been a substantial change in the conditions affecting the structure or Site or the proposed Project is substantially different from the previous Application, the City may find that the request is sufficient to warrant consideration prior to the 1 year period.

H. Enforcement

- 1) All work performed pursuant to a Certificate of Appropriateness issued under this article shall conform to any conditions or requirements included therein. It shall be the duty of the building inspector or their designee to inspect periodically any such work to assure compliance. In the event work is not being performed in accordance with the Certificate of Appropriateness, the Building Official or their designee shall issue a stop-work order, and all work shall immediately cease. No further work shall be undertaken on the Project as long as a stop-work order is in effect.
- 2) A stop-work order may be lifted following submission and approval of plans for corrective action or work, or other plans to bring the Project into compliance with the conditions or requirements of the Certificate of Appropriateness or other approvals.

Sec. 14.09.011 COA Required for Demolition or Relocation.

- A. A permit for Demolition, Removal, or Relocation for any local, state, or national Historic Landmark or any structure or Site within a Historic District shall not be granted by the City without the review and approval of a Certificate of Appropriateness by the Historic Landmark Commission in accordance with the provisions of this article.
- B. Stay of demolition. No permit for the demolition of a designated local, state, or national Historic Landmark— or any contributing structure within a Historic District—shall be issued by the City until at least 60 calendar days after the filing of a complete demolition application. The purpose of the 60-day stay is to allow the Historic Landmark Commission and City staff reasonable time to assess the significance of the structure, explore alternatives to demolition (including relocation, adaptive reuse, or incorporation into redevelopment plans), facilitate discussions with the property owner regarding preservation incentives or solutions, and allow time for public input. The 60-day stay applies to partial or total demolition. The 60-day stay shall run concurrently with the review and decision timelines for a Certificate of Appropriateness under Sec. C, and no demolition permit shall be issued until both (1) a Certificate of Appropriateness has been approved or deemed approved, and (2) the 60-day stay period has expired.
- C. Procedure for COA for Demolition
 - 1) An Application for a Certificate of Appropriateness shall contain the following minimum information:
 - a) Application fee as established in the City’s Master Fee Schedule;
 - b) Owner and agent contact information;

- c) A detailed description of the reason the proposed Demolition is necessary;
 - d) Location of the proposed Demolition;
 - e) Evidence of the existing conditions of the property which justify the need for Demolition;
 - f) A detailed description of the methods of Demolition including the process and procedure for Removal of all debris and how surrounding properties will be protected during the Demolition process;
 - g) Any other information that the City may deem necessary in order to determine the need for the proposed Demolition.
- 2) The Commission shall hold a public hearing on the Application within 45 days after the date a complete Application is Filed with the City. The Applicant, property owner, and all property owners located within two hundred 200 feet of the property proposed to be demolished shall be mailed a written notice 10 days prior to the hearing.
- 3) When considering the Certificate of Appropriateness for Demolition, the Historic Landmark Commission shall consider the following:
- a) The historic value of the Structures or Site;
 - b) The state of repair of the Structures or Site;
 - c) The existing and potential usefulness, including the economic usefulness, of the Structures, buildings or objects on the Lot, parcel or Site;
 - d) The reasons for preserving the Structures, buildings or objects on the Lot, parcel or Site;
 - e) The character of the neighborhood; and
 - f) Any other factors the Historic Landmark Commission deems appropriate when considering the proposed Demolition.
- 4) When considering the Certificate of Appropriateness for Relocation, the Historic Landmark Commission shall consider the following:
- a) The style of Construction and compatibility with the local Historic District;
 - b) The historic value and structural state of the Structure;
 - c) The historic value of the Site;
 - d) The reasons for preserving the Structure on an alternate Site;
 - e) The character of the neighborhood;
 - f) Any other factors the Historic Landmark Commission deems appropriate when considering the proposed Demolition.
- 5) If the Historic Landmark Commission determines, that the evidence supports the Demolition, Removal or Relocation of the Structure or if the Historic Landmark Commission determines that the interest of preserving historic values will not be adversely affected by such Demolition, Removal or Relocation that the interest of preserving historical values can best be served by the Removal of the

Structures, buildings or objects, it shall issue a Certificate of Appropriateness for Demolition of the Structures or Site.

- 6) If no action has been taken by the Historic Landmark Commission within 60 days of the original receipt by the Historic Landmark Commission of the application, the Certificate of Appropriateness for Demolition shall be deemed approved by the Historic Landmark Commission, provided that no demolition permit may be issued until the 60-day stay required by Sec. B has expired.
- 7) Any Applicant who is dissatisfied with the action of the Historic Landmark Commission relating to the issuance or denial of a Certificate of Appropriateness shall have the right to Appeal the determination to the City Council. The Applicant has 15 calendar days from date of the Historic Landmark Commission action to file for the Appeal. The Appeal request will be placed on the next available City Council agenda. To be considered, the Appeal shall set forth the grounds for such Appeal and shall provide the City with any pertinent evidence and all related documentation related to the Appeal. The City Council shall use the adopted approval criteria for the Appeal review.

Sec. 14.09.012 Failure to Maintain Resulting in Demolition by Neglect.

A. State of Demolition by Neglect

- 1) No owner or person, firm, corporation or other organization with an interest in real property that is designated as a Historic Landmark, a Structure or Site that has been certified, registered or designated by any federal, state or other authorized body/entity as having historical significance, or any Structure or Site that is located within a local Historic District, shall permit the property to fall into a serious state of disrepair so as to result in the deterioration of any exterior architectural feature which would, in the judgment of the Historic Landmark Commission, produce a detrimental effect upon the character of a Historic Landmark, the district as a whole, or the life and character of the property itself. Examples of such deterioration include:
 - a) Deterioration of exterior walls or other vertical supports.
 - b) Deterioration of roofs or other horizontal members.
 - c) Deterioration of exterior chimneys.
 - d) Deterioration or crumbling of exterior stucco or mortar.
 - e) Ineffective waterproofing of exterior walls, roof, or foundations, including broken windows or doors.
 - f) Deterioration of any feature creating a hazardous condition which could lead to the claim that Demolition is necessary for the public safety.

B. Demolition by Neglect Hearing Procedure

- 1) Upon notification to the Historic Landmark Commission of such a state of disrepair, the Historic Landmark Commission shall notify the owner in writing, informing the owner of the violation and the

specifics of the alleged deterioration, requesting that the owner appear before the Historic Landmark Commission for determination of the existence of detrimental deterioration.

- 2) If, after a public hearing before the Historic Landmark Commission, the Historic Landmark Commission determines that the deterioration has produced a detrimental effect as described in subsection A of this section, the owner shall cure the deterioration by Restoration or other appropriate actions within a reasonable period of time as determined by the Historic Landmark Commission but in no case longer than 180 calendar days from the determination by the Historic Landmark Commission. The owner must comply with all requirements of requesting a Certificate of Appropriateness from the Historic Landmark Commission. Failure of the owner to cure the deterioration within the time specified by the Historic Landmark Commission shall cause the property owner to be subject to penalties as defined in this Articles, which may be assessed civilly or in municipal court.
- 3) Any Applicant who is dissatisfied with the action of the Historic Landmark Commission relating to the issuance or denial of a Certificate of Appropriateness shall have the right to Appeal the determination to the City Council. The Applicant has 15 calendar days from date of the Historic Landmark Commission action to file for the Appeal. The Appeal request will be placed on the next available City Council agenda. To be considered, the Appeal shall set forth the grounds for such Appeal and shall provide the City with any pertinent evidence and all related documentation related to the Appeal. The City Council shall use the adopted approval criteria for the Appeal review.

Sec. 14.09.013 Incentives for Historic Landmarks.

A. Continuation of Existing Incentives

- 1) All properties previously granted an incentive (refund of City taxes) under section 14.03.002 of the Bastrop Code of Ordinances as of the date of ordinance no. 2018-03 shall be eligible to maintain the incentive and are specifically saved from repeal; however, the City Council may modify or end the program at any time at the City's discretion. A list of all properties subject to the incentive, along with the determination of what historic elements are to be included in the valuation of the incentive, shall be maintained on file in the City's Historic Preservation Officer's and the City Secretary's office.

B. New Applications for Incentives

- 1) To encourage Historic Preservation, the City may offer an incentive to owners of local historic landmarks to encourage the stabilization, Rehabilitation and renovation of properties designated as historic landmarks. The incentives may include:
 - a) Historic landmark marker. Owners of qualifying historic landmarks will be presented with an official Historic Landmark marker to designate the Structure, with the cost of the marker borne by the City.

- b) Property tax refund. Owners of qualifying historic landmarks may be eligible for a refund of a portion of their City property taxes, provided under paragraph (2) below.
 - 2) An owner seeking inclusion in the incentive program shall submit an application to the Historic Preservation Officer to determine whether the property meets the criteria for a local Historic Landmark. Incentives will be granted upon the favorable recommendation of the Historic Landmark Commission and approved by the City Council.
- C. Calculation for Refund Incentives
 - 1) The amount of the refund shall be based on a uniform percentage of the assessed value of the Contributing Structures, determined by the City Council, each budget year, which can be financed by the amount of general funds appropriated for such refunds. Refunds shall be based on the assessed value of the historic improvements only and shall exclude the value of the underlying land or any noncontributing Structures. Refunds will be based on taxes paid in full by July 31. Eligibility for such refund shall require compliance with all requirements of this article.
- D. Required Maintenance Standards
 - 1) To be eligible to receive the annual refund, all buildings and the exterior premise of a Historic Landmark property shall be properly maintained to achieve a presentable appearance, avoid hazardous conditions, and meet the following minimum Standards:
 - a) Roof. The roof shall not have any missing or broken shingles, significant buckling, warping, or peeling of the surface and must be clear of vegetation. There shall be no Signs of decay, dry rot or structural integrity issues in the roof structure.
 - b) Exterior walls. The exterior walls shall not have any missing boards, bricks or other materials. No Signs of cracks, dry rot or decay should be evident. Except for materials that have been designed to remain untreated, all exterior wood, composition or metal surfaces shall be protected from the elements by paint or other protective covering. Surfaces shall be maintained to be kept clean and free of flaking, loose, or peeling paint or covering.
 - c) Foundations. The foundation shall not have any significant cracking, shifting, or erosion. For pier and beam foundations, skirting should be in good condition and have no missing sections. The foundation shall be in good condition and not have missing foundation supports or Signs of sagging.
 - d) Exterior doors. Doors shall be maintained to be structurally sound, fit within frames to be weatherproof, and have hardware that is in good condition.
 - e) Windows. Windows shall be fully supplied with window glass, which is glazed and is without cracks or broken panes, shall have sashes in good condition, which fit within the frames, and maintained to exclude adverse weather elements from entering the Structure.

- f) Porches. Every porch shall be maintained to be free of missing, defective, rotting or deteriorated foundations, supports, floors and steps, to be safe to use and kept in sound condition and in good repair.
 - g) Stairways. Stairways shall be maintained free of rotted or deteriorated supports. Handrails and/or railings shall be firmly fastened and maintained in good conditions.
 - h) Accessory Structures. All Structures accessory to the dwellings, including detached garages, shall be maintained to be structurally sound, neatly maintained and in good repair.
 - i) Fences and walls. If any fence, retaining wall, or similar Structure is not found to be in a good state of structural repair, it shall be removed, replaced or repaired as required.
 - j) Landscaping. All landscaping shall be maintained in a presentable appearance. Any landscaping or vegetation that is causing damage to the Structure must be removed.
 - k) Decorative features. Any other decorative elements of the Site shall be maintained in good repair with property anchorage and in a safe condition.
- 2) If a Historic Landmark property has been determined by the Historic Preservation Officer, the Building Official, and Code Enforcement Official to be inadequately maintained, the property owner will be notified in writing and given 30 days to correct the deficiencies. If the repairs are not completed and Standards are not met, the incentive will not be paid. An aggrieved property owner may Appeal that determination to the City Council.

E. Loss of Incentives

- 1) No owner, owner's agents, contractors and/or representatives shall alter or totally or partially destroy any Historic Landmark subject to incentives under this section without first obtaining a Certificate of Appropriateness or Demolition permit in accordance with the terms of this article. If a Historic Landmark subject to incentives is altered or totally or partially destroyed without a Certificate of Appropriateness, the owner shall be required to restore the Structure to its original state, within a reasonable period of time as established by the Historic Landmark Commission but in no case longer than 180 calendar days from the date of any notice of violation provided to the property owner. No incentives will apply during the time that the owner is restoring the property. Failure to restore the historical landmark to its pre-destruction condition shall subject the owner to the penalties set forth in this article and the owner shall:
- a) No longer be entitled to the incentives set forth herein; and
 - b) Immediately remit to the City monies in an amount equal to the total city tax revenues that were refunded in the current and prior years because of the incentives, plus interest calculated at an annual rate as established by the then-current Texas Private Prompt Payment Act.

- 2) If an owner has obtained a Certificate of Appropriateness for Demolition or Relocation, then the incentive for the Structure will cease immediately upon the Demolition or Relocation, but no remittance of past refunds is required.
- 3) Transferability of Incentives
 - a) The benefits of the incentive program relating to historic Structures under this section are transferable and run with the property.

Sec. 14.09.014 Economic Hardship.

A. Economic Hardship Application Procedure

- 1) After receiving written notification from the Historic Landmark Commission of the denial of a Certificate of Appropriateness, or an application to demolish, an Applicant may commence the hardship process. No building permit or Demolition permit shall be issued unless the Historic Landmark Commission makes a finding that hardship exists.
- 2) When a claim of economic hardship is made due to the effect of this article, the owner must prove that:
 - a) The property is incapable of earning a reasonable return, regardless of whether that return represents the most profitable return possible;
 - b) The property cannot be adapted for any other use, whether by the current owner or by a purchaser, which would result in a reasonable return; and
 - c) Efforts to find a purchaser interested in acquiring the property and preserving it have failed.
- 3) The Applicant shall consult in good faith with the Historic Landmark Commission, local Preservation groups and interested parties in a diligent effort to seek an alternative that will result in Preservation of the property. Such efforts must be shown to the Historic Landmark Commission.
- 4) The commission shall hold a public hearing on the Application within 60 days from the date the Application is received by either the building inspector or the Preservation Officer. Following the hearing, the Historic Landmark Commission has 30 days in which to prepare a written recommendation to the building inspector or other official. In the event that the Historic Landmark Commission does not act within 90 days of the receipt of the Application, a permit may be granted by the building inspector.
- 5) All decisions of the Historic Landmark Commission shall be in writing. A copy shall be sent to the Applicant by certified mail and a copy filed with the City clerk's office for public inspection. The commission's decision shall state the reasons for granting or denying the hardship Application.
- 6) An Applicant submitting a hardship Application who is dissatisfied with the decision of the Historic Landmark Commission relating to the approval or denial of such Application shall have the right to Appeal the Historic Landmark Commission's decision to the City Council. The Applicant has fifteen

(15) calendar days from date of the Historic Landmark Commission action to file for the Appeal. The Appeal request will be placed on the next available City Council agenda. To be considered, the Appeal shall set forth the grounds for such Appeal and shall provide the City with any pertinent evidence and all related documentation related to the Appeal. The City Council shall use the adopted approval criteria for the Appeal review.

Sec. 14.09.015 Penalties.

- A. Any person, firm, association of persons, corporation or other organization violating the provisions of this article shall be deemed to be guilty of a misdemeanor and, upon conviction, shall be fined an amount not to exceed the amount set out in the City's Code of Ordinances. Each day that a violation continues shall be deemed a separate and distinct offense. Violations of this article may be enforced civilly and/or in municipal court, at the City's discretion.

ARTICLE 14.10 SPECIAL FLOOD HAZARD AREA

Sec. 14.10.001 Purpose and Authority.

- A. Purpose. The purpose of the flood hazard overlay district is to promote the public health, safety, and general welfare and to minimize public and private losses due to flood conditions in specific areas by provisions intended to:
- 1) Restrict or prohibit uses which are dangerous to health, safety and property due to water or erosion hazards, or which result in damaging increases in erosion or in flood heights or velocities.
 - 2) Control the alteration of natural floodplains, stream channels, and natural protective barriers which are involved in the accommodation of flood waters.
 - 3) Control filling, grading, dredging and other development which may increase erosion or flood damage.
 - 4) Prevent or regulate the construction of flood barriers which will unnaturally divert flood waters or which may increase flood hazards to other lands.
- B. Relationship to Other Regulations
- 1) The SFHA Overlay supplements the underlying zoning district and the City's Flood Damage Prevention Ordinance.
 - 2) Where standards conflict, the more stringent standard governs.
 - 3) Compliance with this overlay does not relieve any obligation to comply with all other applicable City, State, and Federal requirements.
- C. Authority. This Section is based on the City's authority under Chapter 51 of the Texas Local Government Code and the Texas Water Code 16.315.
- D. Applicability and Mapping
- 1) The SFHA Overlay applies to all lands within the City's planning and zoning jurisdiction identified by FEMA on the effective Flood Insurance Rate Maps (FIRMs) as Zone A, Zone AO, or Zone AE, including associated regulatory floodways.
 - 2) When the base flood elevation data has not been provided by FEMA, the City may apply the overlay standards by reasonably utilizing any base flood elevation data, best available data, and floodway data available from a Federal, State, or other source.
- E. Administration
- 1) The Floodplain Administrator administers this overlay in coordination with the Director of Development Services or his/her designee.
 - 2) Development within the SFHA Overlay requires all applicable zoning, platting, site and building approvals and, where required, a Floodplain Development Permit.
 - 3) Submittals must include: current FIRM panels; Elevation Certificates; Base Flood Elevations (BFEs); floodway extent; existing/proposed topography; grading/fill limits; drainage paths; and any required hydrologic and hydraulic analyses sealed by an engineer licensed in the State of Texas .

Sec. 14.10.002 Development Requirements and Restrictions

A. General Development Standards

- 1) Open Space / Conservation. Land within the regulatory floodway and areas below the BFE that are not used for permitted access or utility crossings shall be preserved as open space and protected by either:
 - a) Public dedication; or
 - b) A recorded conservation easement granted to the City or a City-approved land trust, in a form acceptable to the City Attorney.
- 2) Limitations on New Development in SFHA. No new principal structures or land-disturbing activity shall occur within the SFHA unless the lot of record would otherwise have no buildable area outside the SFHA or would be left with less buildable area than allowed under subsection (G). Development that relies on this exception must meet all conditions in subsection (G).
- 3) Prohibited Uses. New critical facilities are prohibited within the SFHA.
- 4) Riparian Buffers. A minimum 100-foot undisturbed buffer from the top of bank of waterways within the SFHA is required. Selective clearing for invasive removal, habitat restoration, and utility/transport crossings may be allowed by administrative approval if overall buffer function is maintained.
- 5) Utilities and Access. New or replaced utilities must be flood-resistant and located to minimize flood damage. Access routes serving structures must be passable during the 1% annual-chance event or provide an emergency access plan acceptable to the City.
- 6) Stormwater Compatibility. Site design shall maintain or improve existing flood storage and conveyance and comply with all City stormwater criteria; water-quality and volume controls may not reduce required compensatory storage.

B. No-Adverse-Impact Analyses

- 1) Floodway. Any encroachment in the regulatory floodway shall demonstrate no rise in BFEs (FEMA “no-rise” certification) and no increase to off-site flood elevations, velocities, or conveyance.
- 2) SFHA Outside Floodway. Grading, channel modifications, crossings, or encroachments within Zone A/AE outside the floodway must demonstrate no measurable adverse impact to off-site conditions; analyses shall be sealed by a Texas P.E.

C. No Buildable-Area Exception—Existing Lots

- 1) Permit. A Floodplain Development Permit is required.
- 2) Impervious-Cover Cap. Maximum impervious cover for the lot shall be reduced by at least ten (10) percentage points from the underlying district maximum. This cap limits total hardened area; it does not authorize structural pad fill.
- 3) Subdivision/Rezoning Limitation. The lot may not be further subdivided nor rezoned to a more intensive district.
- 4) Elevation Method / Pad-Fill Ban

- a) No pad fill. Finished floors may not be achieved by earthen or granular pad fill within the SFHA. Structures shall meet elevation requirements using piers, piles, columns, or stem walls, with any structural backfill contained entirely within foundation walls.
 - b) Allowed minor fill (not for elevation). Limited engineered fill is allowed only for: utility bedding; driveway/sidewalk/ADA transitions; public street sections; erosion control; and regrading needed to maintain positive drainage—provided it is not used to achieve finished-floor elevation and meets the no-adverse-impact standard.
 - c) Floodway. No fill in the regulatory floodway except where specifically permitted by FEMA/City with a sealed no-rise certification.
- 5) Compensatory Storage / No-Net-Fill. Any placement of fill or excavation that disturbs 5,000 sq ft or more within the SFHA shall provide minimum 1:1 compensatory flood storage within the same hydraulic reach at equivalent elevations.
 - 6) All Other Flood Standards. All Flood Damage Prevention Ordinance requirements apply, including building/utility elevation, flood-resistant materials, and enclosure limits.
- D. Subdivision Standards (Lots Containing SFHA)
- 1) Plat Content. Preliminary and final plats shall delineate SFHA and floodway boundaries, BFEs, and City-adopted studies; label open-space/conservation areas; and record drainage/floodplain easements.
 - 2) Lot Design / Clustering. Create buildable pads outside the SFHA where feasible through clustering and lot reconfiguration. Lots shall not rely solely on pad fill to place structures above BFE.
 - 3) Easements & Dedications. Dedicate drainage and floodplain easements sufficient to preserve conveyance and storage, including access for maintenance.
 - 4) Utilities & Streets. Design to minimize flood damage and avoid longitudinal encroachments in the floodway. Street and utility crossings shall be designed to maintain conveyance.
 - 5) Density Transfer & Cluster Incentives (SFHA Preservation). A subdivision that preserves $\geq 90\%$ of the on-site SFHA as permanent open space per subsection (E)(1) is eligible for the following incentives:
 - a) Lot-count protection (transfer). Maximum lot count = $\text{Gross Site Area} \div \text{Base District Minimum Lot Size}$ (rounded down). This allows density to transfer from the SFHA to buildable areas outside the SFHA.
 - b) Minimum lot-size reduction. Eligible projects may reduce the base district minimum lot size by up to 50%, but not below 5,000 square feet, to facilitate clustering outside the SFHA. All other dimensional standards apply unless modified by an approved cluster plan.
 - c) Form of open space. The preserved SFHA must be recorded by plat note and easement/dedication; open space shall be contiguous where practicable and may incorporate trails/greenways if consistent with floodplain function.

- d) No net increase over gross. Incentives do not authorize more lots than permitted by (5)(a); they allow those lots to fit on smaller, safer pads outside the hazard area.
 - e) Construction limits. Incentivized lots shall not rely on pad fill to place structures above BFE; elevation-on-foundation methods are required, except as allowed by G(4)(d) for existing lots of record.
- E. Nonconformities. Existing lawful structures and uses within the SFHA that become nonconforming under this overlay may continue subject to Chapter 14 nonconformities provisions and the Flood Damage Prevention Ordinance. Repairs, additions, and improvements must comply with applicable substantial improvement/substantial damage thresholds.

Sec. 14.10.003 Variances and Appeals

- A. Variances and Appeals. Relief from this overlay may be considered only through the established variance procedures in Sec. 3.17.007 - Administration. (d) variance procedures in the Code of Ordinances.

Sec. 14.10.004 Definitions

- A. Definitions. For purposes of this overlay, terms have the meanings in the Flood Damage Prevention Ordinance; where undefined there, NFIP definitions control. The following are added for clarity:
- 1) Pad fill (for structural elevation): Earthen or granular fill placed to raise any portion of a building site within the SFHA to meet finished-floor elevation or avoid flood regulation.
 - 2) Existing lot of record. A lot lawfully created and recorded prior to the effective date of this overlay, which has not been re-platted or boundary-adjusted thereafter in a manner that reduced buildable area outside the SFHA.
 - 3) Critical facility: Facilities essential for health, safety, and disaster response, including but not limited to hospitals, emergency operations centers, police and fire stations, water/wastewater plants, substations, and facilities housing hazardous materials.
 - 4) Top of bank: The break in slope that typically defines the upper edge of an active channel.
 - 5) Conservation easement: A recorded legal instrument that permanently restricts development and preserves floodplain functions, granted to the City or a City-approved land trust in a form acceptable to the City Attorney.
 - 6) No-adverse-impact: A condition whereby a development activity does not measurably increase flood elevations, velocities, or flood hazards on other properties, as demonstrated by acceptable engineering analysis.
 - 7) Hydraulic reach: The continuous segment of a watercourse where hydraulic conditions are interdependent for purposes of storage and conveyance

ARTICLE 14.11 PLANNING AND ZONING COMMISSION

Sec. 14.11.001 General

- A. General: The Planning & Zoning Commission shall function according to the following criteria that establish membership and operating procedures.

Sec. 14.11.002 Members, Officers, and Alternatives Qualifications

- A. There is hereby created, in accordance with Subchapter 211.007 of the Texas Local Government Code and the City's Charter, a Planning & Zoning Commission that shall consist of 9 citizens who reside in the City Limits.
- 1) At least 3 members shall have a known and demonstrated competence or knowledge in land use and development as may be exhibited by the following professions: attorney, architect, city planner, design professional, landscape architect, real estate developer, civil engineer, construction project manager, and construction superintendent.
 - 2) Members shall be appointed by the Mayor and confirmed by City Council for a term of 3 years.
 - 3) Terms of 1/3 of the Planning & Zoning Commission shall expire each year upon September 30th, or until a successor is appointed.
 - 4) Vacancies and unexpired terms of members shall be filled by the appointment of the Mayor and confirmed by City Council. These appointments shall be for the remainder of the term.
 - 5) Members may be removed from office at any time by a majority vote of the City Council for any reason. All members serve without compensation.
 - 6) Attendance requirements for the Planning & Zoning Commission members are the same attendance requirements as set forth in the Code of Ordinances, Section 1.02.002(b) for Advisory Boards.
- B. The City staff shall keep minutes of all meetings held by the Planning & Zoning Commission and full record of all recommendations to be made by the Planning & Zoning Commission to the City Council. Minutes shall constitute a report and record of all Planning & Zoning Commission meetings, including hearings.
- C. A Chair and Vice-Chairman shall be elected by the Planning & Zoning Commission from its membership, each to hold office for 1 year or until replaced by a majority vote of the Planning & Zoning Commission.
- D. Additional alternates may be appointed by the Council when it's deemed necessary and occurs in the same manner as the appointment of members.

Sec. 14.11.003 Quorum and Voting

- A. Five members of the Planning & Zoning Commission shall constitute a quorum, and all members, including the presiding chairman, shall have the right of 1 vote each, a quorum being present.
- B. All actions by the Planning & Zoning Commission shall be by a majority vote of those members present including the passage of any recommendation to the City Council.

- C. If any member has a conflict of interest, as defined by THE City of Bastrop’s Ethics Ordinance in Article 1.15 of the Code of Ordinances, in review of any item on the Planning & Zoning Commission's agenda, the member shall state such for the record and abstain from any discussion and from voting on the matter.

Sec. 14.11.004 Meetings:

- A. The Planning & Zoning Commission shall convene for regular meetings at least once a month unless otherwise determined by the Chair or the Director of Development Services.
- B. The meetings shall be in the City Hall or other specified locations as may be designated by the Chair or Vice Chair, in the absence of the Chair. Special meetings shall be held at such intervals as may be necessary to orderly and properly transact the business of the Planning & Zoning Commission as called by the Chair or the Director of Development Services.

Sec. 14.11.005 Powers and Duties:

- A. The Planning & Zoning Commission shall be an advisory body to the City Council and shall make recommendations regarding amendments to the Comprehensive Plan, changes of Zoning and shall be the final authority for certain plats, as specified in Chapter 10 of the Code of Ordinances, and they may review and recommend other planning-related matters.
- B. The Planning & Zoning Commission shall conduct an annual review of the City's Comprehensive Plan and the Bastrop Development Code and be prepared to make such recommendations to the City Council as deemed necessary to keep the City's Comprehensive Plan and the Bastrop Development Code current with the needs and uses of the City. The Planning & Zoning Commission shall serve in an advisory capacity on any planning related item(s) in the City.

Sec. 14.11.006 Procedure on Zoning Hearings:

- A. The procedure and process for Zoning changes and/or amendments shall be completed in accordance with this chapter and in accordance with Chapter 211 of Local Government Code.

ARTICLE 14.12 ZONING BOARD OF ADJUSTMENTS

Sec. 14.12.001 Creation, Applicability, and Exemptions:

- A. There is hereby created and established a Board to be called the City of Bastrop Zoning Board of Adjustment (ZBA). The ZBA shall hear Appeals from Administrative decisions regarding Zoning, and in appropriate cases, subject to appropriate conditions and safeguards, may authorize Variances from the terms of the Bastrop Development Code.
- B. Zoning Board of Adjustment Authority and Jurisdiction (TLGC Chapter 211). The Zoning Board of Adjustment (ZBA) is established and shall operate pursuant to Texas Local Government Code (TLGC), Chapter 211. The ZBA's jurisdiction under this Article is limited to zoning matters authorized by TLGC Chapter 211, including zoning-related appeals alleging error in an order, requirement, decision, or determination made in the administration or enforcement of the City's zoning regulations, and zoning variances or other relief that TLGC Chapter 211 expressly authorizes a board of adjustment to grant. The ZBA shall not grant relief that is not authorized by TLGC Chapter 211.
- C. Matters Governed by Other State Law; Article-Specific Appeal Procedures Control.
 - 1) Exempt matters. Appeals, exceptions, credits, alternative compliance determinations, administrative adjustments, or other relief requests that are authorized or governed by a chapter of state law other than TLGC Chapter 211 are not "zoning variances" and are not within the ZBA's jurisdiction under this Article, unless the applicable article of this Development Code expressly designates the ZBA to hear the matter.
 - 2) Applicable article governs. For exempt matters, the appeal and decision process shall be as stated in the applicable article of this Development Code, including but not limited to:
 - a) Tree mitigation and tree removal regulation matters adopted under TLGC Chapter 212 (including TLGC Section 212.905);
 - b) Sign regulation matters adopted under TLGC Chapter 216;
 - c) Special Flood Hazard Area (SFHA) and floodplain management regulations adopted to maintain participation in the National Flood Insurance Program (NFIP) and under other applicable state and federal authority, shall follow the Variance and Appeal process under Section 3.17.006 of the City's Code of Ordinances as authorized under Chapter 51 of the TLGC and the Texas Water Code.
 - 3) Combined requests. If an application includes both (i) a zoning variance or zoning appeal under TLGC Chapter 211 and (ii) a request for relief governed by another article and state-law authority, each request shall be reviewed and decided under the procedures and standards that apply to that specific request, and the ZBA shall act only within the scope of its TLGC Chapter 211 authority unless the other applicable article expressly assigns that additional matter to the ZBA.

Sec. 14.12.002 Membership; Terms of Office

- A. The ZBA shall consist of 5 regular members and 2 alternate members who shall be appointed by the mayor confirmed by the City Council, in accordance with state law.
- B. Members of the ZBA shall regularly attend meetings and public hearings of the ZBA and shall serve without compensation. Attendance requirements for the Planning & Zoning Commission members are the same attendance requirements as set forth in the Code of Ordinances, Section 1.02.002(b) for Advisory Boards.
- C. Any vacancy of a regular member shall be filled by an alternate member only for the unexpired term of the member whose term becomes vacant.

Sec. 14.12.003 Authority of the Board

A. The ZBA has the authority, subject to the Standards established in Sections 211.008 to 211.011 of the Texas Local Government Code and those established herein, to exercise the following powers and perform the following duties:

- 1) Hear and decide an Appeal that alleges error in an order, requirement, decision, or determination made by an administrative official in the enforcement of this Code;
 - 2) Authorize the expansion or continuation of a nonconforming use or Structure; and
 - 3) Authorize in specific cases a Variance from the terms of this Code.
 - 4) In exercising its authority under "A" above, the ZBA may reverse or affirm, in whole or in part, or modify the administrative official's order, requirement, decision, or determination from which an Appeal is taken and make the correct order, requirement, decision, or determination, and for that purpose the ZBA has the same authority as the administrative official.
- B. The concurring vote of 75% of the members of the ZBA is necessary to:
- 1) Reverse an order, requirement, decision, or determination of an administrative official;
 - 2) Decide in favor of an Applicant on the proposed expansion of a nonconforming use or structure; or
 - 3) Authorize a Zoning Variance from the terms of this Bastrop Development Code.

Sec. 14.12.004 Quorum and Voting

Each case before the ZBA must be heard by at least 75% of its members or alternate members. Meetings of the ZBA are held at the call of the presiding officer or the Director of Planning & Development. All meetings of the ZBA shall be open to the public. The ZBA shall keep minutes of its proceedings that indicate the vote of each member. The minutes and records of the ZBA shall be filed promptly in the City Secretary's Office and are public records.

Sec. 14.12.005 Variances

- A. The ZBA may authorize a Variance from these Standards when, in its opinion, undue hardship will result from requiring strict compliance. In making the findings hereinafter required, the ZBA shall consider the nature of the proposed use of the land involved, existing uses of land in the vicinity, and the probable effect of such Variance upon traffic conditions and upon the public health, safety, convenience and welfare in the vicinity.

- B. In order to grant a Variance from these zoning Standards, the ZBA must make written findings that unnecessary hardship exists, using the following criteria:
- 1) The variance is not contrary to the public interest and will not be detrimental to the public health, safety, or welfare or injurious to other property in the area.
 - 2) Due to special conditions peculiar to the property, a literal enforcement of this Code would result in unnecessary hardship as applied to the property.
 - 3) The variance is necessary to permit the applicant to preserve and enjoy a substantial property right, and the spirit and intent of this Code are observed and substantial justice is done.
 - 4) The unnecessary hardship is based on conditions related to the property (including exceptional narrowness, shallowness, shape, topography, or similar extraordinary physical conditions) and is not shared generally by other property in the same district or vicinity.
 - 5) The unnecessary hardship is not self-created. The Board shall deny a variance if the requested relief is based on a condition created by a person with an interest in the property.
 - 6) Financial impact alone (including loss of profits, personal circumstances, or higher development costs typical of the district) does not constitute unnecessary hardship; however, in evaluating unnecessary hardship as applied to a structure, the Board may consider the grounds listed in Texas Local Government Code Section 211.009(b-1).
 - 7) The applicant bears the burden of proof, and the evidence supporting each finding must be documented in the record.
 - 8) A variance shall not authorize a use that is not otherwise permitted in the zoning district.

Sec. 14.12.006 Nonconforming Uses and Structures

- A. The ZBA shall have the authority to authorize the expansion or enlargement of a nonconforming use, or the expansion, enlargement or structural Alteration to a Structure containing a nonconforming use, when such an expansion, enlargement or Alteration would not tend to prolong the life of the nonconforming use. Upon review of the facts, the ZBA may establish a specific period of time for the occupancy to revert to a conforming use; and
- B. To authorize the Reconstruction and occupancy of a nonconforming Structure, or a Structure containing a nonconforming use, where such Structure has been damaged by fire, the elements, or other cause to the extent of more than 60%, but less than the total, of the replacement cost of the Structure on the date of the damage. Such action by the ZBA shall have due regard for the property rights of the person or persons affected, and shall be considered regarding the public welfare, character of the area surrounding such Structure, and the conservation, Preservation and protection of property; and
- C. ZBA shall have the authority to authorize the enlargement, expansion, or repair of a nonconforming Structure in excess of 60% of its current value. In such instance, current value shall be established at the time of

Application for a hearing before the ZBA. If such expansion or enlargement is approved by the ZBA, all provisions of the district that the Structure is located shall apply to the new Construction on the Lot or parcel.

- D. To authorize the occupancy of an abandoned nonconforming Structure. Such action by the ZBA shall have due regard for the Comprehensive Plan, the property rights of the person or persons affected and shall be considered in regard to the public welfare and safety, character of the area surrounding such Structure, and the conservation, Preservation and protection of property.

Sec. 14.12.007 Procedure for Variances

- A. An Application for a Variance shall be made in writing in a form prescribed by the ZBA and shall be accompanied by the required fee in compliance with the Master Fee Schedule, a Site Plan and additional information may be requested in order to properly review the Application. Such information may include, but is not limited to, an existing Plat and Site Building plans.
- B. The Director of Planning & Development or other authorized officials shall visit the Site and the surrounding area where the proposed Variance will apply and shall report their findings to the ZBA.
- C. The ZBA shall hold a public hearing no later than 45 days after the date the Application for action or an Appeal is filed. Notice of a public hearing shall be provided to all property owners within 200 feet of the affected property within 10 days prior to the public hearing and also published in the official local newspaper within 10 days prior to the public hearing.
- D. The ZBA shall not grant a Variance unless it finds, based on competent evidence, that each of the conditions in requirements for granting the Variance has been established. The ZBA's findings, together with the specific facts that the findings are based on, shall be incorporated into the official minutes of the ZBA meeting that the Variance is granted or denied.
- E. The ZBA may impose such additional conditions, limitations and safeguards as it deems appropriate upon the granting of any Variance. Violation of any such condition, limitation or safeguard shall constitute a violation of this Code.
- F. Any rights authorized by a Variance that are not exercised within 1 year from the date of granting such Variance shall lapse and may be reestablished only after Application and a new hearing in accordance with this.

Sec. 14.12.008 Appeals of Administrative Decisions

- A. Any of the following persons may appeal to the ZBA a decision made by an administrative official that is related to a specific Application, address, Project, or other non-application specific decisions made by an administrator of this code or city official:
 - 1) A person who:
 - a) Filed the Application that is the subject of the decision;
 - b) is the owner or representative of the owner of the property that is the subject of the decision; or

- c) is aggrieved by the decision and is the owner of real property within 200 feet of the property that is the subject of the decision; or
 - d) any officer, department, board, or bureau of the municipality affected by the decision.
- B. The appellant must file with the ZBA and the official against whom the Appeal is taken a written notice of appeal specifying the grounds for the Appeal within 20 days after the decision has been rendered. The officer to whom the Appeal is made shall immediately transmit to the ZBA all papers constituting the record of the action that is appealed.
- C. An Appeal stays all proceedings in furtherance of the action that is appealed unless the official from whom the Appeal is taken certifies in writing to the ZBA that facts supporting the official's opinion that a stay would cause imminent peril to life or property. In that case, the proceedings may be stayed only by a restraining order granted by the ZBA or a court of record on Application, after notice to the official, if due cause is shown.
- D. The appellant party may appear at the Appeal hearing in person or by agent or attorney.
- E. If the ZBA finds that the administrative official made an error in the Application or interpretation of the Code in a particular instance, the ZBA may reverse or affirm, in whole or in part, or modify the administrative official's order, requirement, decision or determination that an Appeal is taken, and make the correct order, requirement, decision, or determination.

Sec. 14.12.009 Judicial Review of Board Decisions

- A. Pursuant to Local Government Code, Section 211.011, "Judicial Review of Board Decision," persons aggrieved by a decision of the ZBA may present to a court of record a verified petition stating that the decision of the ZBA is illegal in whole or in part and specifying the grounds of the alleged illegality.
- B. Pursuant to state law, any such petition complaining of the ZBA's decision must be filed with a district court, county court, or county court at law within 10 days after the date of the ZBA's decision is filed in the Planning & Development Department.

Sec. 14.12.010 Fees:

- A. Fees shall be as provided for in the Master Fee Schedule.

ARTICLE 14.13 ADMINISTRATION AND PROCEDURES

Sec. 14.13.001 Development Process.

A. Development Review Committee (DRC)

The City of Bastrop Development Review Committee (DRC) is comprised of City staff who oversee the development process. The DRC can approve applications that meet the intent, standards, and requirements, if the development is deemed administratively approvable and requires no public hearing by state law or by the Bastrop Development Code and Subdivision Regulations.

The DRC is committed to working with each applicant throughout the process to meet the intent of the Development Code allocations of the City, and the goals of the adopted plans and policies.

Development in Bastrop will be facilitated by the DRC, a collaborative team of staff members dedicated to development projects success. The DRC will conduct a series of technical reviews and analysis of each development in a holistic manner. The intent is to provide quick turnaround reviews, reduce comment conflicts, and to provide consistent feedback to each applicant and development.

B. Development Process.

- 1) The development application submittal and review process consists of submitting a development application to the City and obtaining review of the development proposal by the DRC.
- 2) The submittal and review process includes:
 - a) A pre-application meeting and site visit;
 - b) Application submittal and review;
 - c) Application approval:
 - (1) Administrative decision; or
 - (2) A recommendation and subsequent decision from one or more of the following public hearing bodies:
 - (a) Zoning Board of Adjustment (ZBA),
 - (b) City Council, and/or
 - (c) Planning and Zoning Commission.
 - d) Application for construction document review and permits;
 - e) Inspections; and,

- f) Certificate of Occupancy.
- 3) Detailed Development Process:
- a) Step 1: Pre-development meeting and site visit:
 - (1) Development activities begin with a pre-application meeting request to the City.
 - (2) The primary purpose of the pre-application meeting is for staff to help identify the scope of the development proposal, so that the City can determine the appropriate submittal requirements and process(es), including whether the development will require administrative or public approval.
 - (3) The site visit will:
 - (a) Identify the geographic center of the development;
 - (b) Key features to be preserved on the lot(s);
 - (c) The appropriate Development requirements;
 - (d) Environmental/infrastructure constraints; and
 - (e) Placement of the street network and blocks.
 - b) Step 2: Development application submittal and review:
 - (1) After the development application submission is deemed complete, the Development Services Department will distribute the application to members of the DRC and begin the review process. Review times vary upon whether approval is achieved administratively or through the public hearing process.
 - (a) Once a complete development application is deemed completed and accepted, the Development Services Department manages the application and follows the specific review processes per application type.
 - (b) See review timelines and checklists made available by the Development Services Department.
 - (2) After review of a development application that requires only an administrative decision, staff will notify the applicant with the following:
 - (a) List of issues to be resolved before a decision will be made on the application; or
 - (b) A written decision on the application.

- (3) The development of a detached residential building in a zoning district which permits single family residential as a primary use, on a platted lot or a lot of record, that complies with current zoning district development standards, may proceed with construction document review and permits.
 - (4) All other development proposals must submit a development application through the Development Services Department for approval before obtaining approval of construction document review and permits.
- c) Step 3: Application for construction document review and permits:
- (1) Step 3 consists of preparing and submitting construction documents for review and obtaining permits for construction activities.
 - (2) Refer to the applicable code section for the detailed requirements for specific applications and submittals.
 - (3) Construction Documents may be submitted with the second review of the Development Application to the Development Services Department.
- d) Step 4: Inspections:
- (1) All permitted construction activities must be inspected by the City.
 - (2) Inspections forms and checklists will be provided by the Development Services Department.
- e) Step 5: Certificate of Occupancy and Certification of Shell Building:
- (1) The Certificate of Occupancy (CO) or Certification of Shell Building is issued in accordance with the City's adopted building and fire codes once the City has determined that all requirements have been satisfied.
 - (2) See International Fire Code and local amendments for requirements.

C. Pre-Application Meetings.

- 1) A pre-application meeting is required prior to the submission of an official development application.
- 2) A pre-application meeting shall be requested accompanied by:
 - a) Location;
 - b) Project narrative describing the proposed development or intent;
 - c) Concept plan (optional).

3) Format:

- a) The pre-application meeting between City staff and the applicant to discuss a proposed development application typically lasts 30 to 60 minutes.
- b) Staff will contact the applicant to schedule the pre-application meeting within 5 days of receipt of the pre-application request.
- c) In general, the pre-application meeting is scheduled within 2 to 3 weeks of the receipt of the pre-application request. Information exchanged at the pre-application meeting allows City staff and the applicant to come to a more complete understanding of the size, scope, and feasibility of the proposal.

4) Outcomes:

Based on the discussion at the meeting and site visit, the proposal will be processed by the Development Services Department:

- a) To determine if the application may be processed administratively or require a public hearing to obtain a decision on the application once submitted.
- b) To provide the applicant with the appropriate development application checklist(s) and any related information; or,
- c) And may require additional information to be submitted, and a subsequent pre-development meeting to be conducted for further review.

D. Permitting.

To ensure compliance with the intent and standards of the Bastrop Development Code and to safeguard the health, safety, and welfare of the public, the City requires the approval of construction documents for most development and construction activity within the City. In addition to the approval of the construction documents, the City requires the issuance of a building, permission to work in the Right-of-way, or when applicable, a permission to place private improvements in the right-of-way permits for most all development and construction activities.

- 1) Maintenance and minor modifications to existing structures may not require the approval of construction documents or the issuance of permits, as determined by the Building Official and/or Fire Chief or their designee, consistent with the authority provided in City ordinances, IBC, or IFC.

E. Inspections.

- 1) Inspections are made for building, electrical, mechanical, plumbing, and zoning compliance for residential, commercial and industrial development, and for the remodeling of existing buildings.

- 2) Water, sewer, paving, concrete, and grading activities also require City inspection.
- 3) As part of the development process, all permitted construction activities must be inspected by the City's Inspection Services staff.
- 4) The review of plans and issuance of permits do not authorize code or ordinance violations that may be discovered by City inspectors at the job site.

F. Certificate of Occupancy (CO).

- 1) Before any development can be occupied or used, an applicant must apply for a CO.
- 2) Additionally, all DRC stipulations must be complied with before the City will issue a Certification-of-Shell Building or a final CO.
- 3) Typically, within three staff working days of submitting an application, the CO or Certification of Shell Building will be issued, provided the development passes a Final Inspection.
- 4) The issuance of a CO shall not be construed as an approval of a violation of the provisions of any City Code or ordinance.
- 5) The City's adopted building code requires certain information to be included on the CO:
 - a) Project address; and
 - b) Name of the owner of the property at the time the certificate was issued.
- 6) The CO stays with the property for in perpetuity, even with changes in ownership. If the property ownership changes during construction, documentation of that fact can be submitted, and a change made to the permit. Refer to the City's Building Code, and amendments for additional information.
- 7) Changes in use, increases in the intensity of use, and expansions of existing developments shall require a new Certificate of Occupancy and may trigger re-review of development standards, as outlined in the Nonconformities Article and Site Development Plan Amendment Section.

G. Temporary Certificate of Occupancy (TCO)

- 1) Under certain conditions, the issuance of a TCO allows temporary occupancy, with the approval of the City Manager, until the building is completed and a Final CO is issued.
- 2) Should the TCO expire prior to the issuance of the Final CO, the expiration will require the City to take appropriate steps as outlined in the City's Building Code and the associated amendments.

Sec. 14.13.002 Zoning Procedures.

A. Purpose & Applicability

- 1) Purpose. Establish a predictable, transparent process for zoning map amendments (rezonings) that implements the Comprehensive Plan and adopted master plans, ensures compatibility, and protects public health, safety, and welfare.
- 2) Applicability. Applies to all zoning map amendments, including district changes, conditional zoning, overlays, and initial zoning of land proposed for annexation (pre-zoning) as provided herein.

B. Pre-Application. A pre-application meeting with Development Services Department is required prior to submittal of any rezoning application.

C. Application. An application shall be submitted through the City's public portal complete with all information.

D. Review & Recommendations

- 1) DRC Technical Review. DRC reviews for compliance with this Code, Comprehensive Plan, and adopted master plans; may request revisions; and prepares a consolidated memo.
- 2) Director's Report. The Director forwards a recommendation (approval, approval with conditions, or denial) to P&Z.
- 3) Planning & Zoning Commission (P&Z). P&Z holds a public hearing, considers staff/DRC recommendations and public input, and issues a recommendation to City Council.
- 4) City Council (Final Action). Council holds a public hearing as well as a second reading at a subsequent meeting and acts by ordinance: approve, approve with conditions, remand to P&Z, or deny.

E. Approval Criteria. In making recommendations and decisions, the reviewing bodies shall consider whether the amendment:

- 1) Implements Adopted Plans. Is consistent with the Comprehensive Plan and applicable master plans (transportation, utilities, parks/open space).
- 2) Ensures Compatibility. Provides appropriate transitions in use, scale, and design to adjacent development; mitigates potential impacts through conditions where needed.
- 3) Provides Adequate Infrastructure. Streets, utilities, drainage, and public safety services are available or can be provided in a timely manner; access and internal circulation are safe and efficient.
- 4) Advances the Public Interest. Furthers health, safety, welfare, and the purposes of this Code without granting special privilege.

F. Public Notices & Hearings

- 1) Non-Comprehensive Zoning Changes
 - a) Mailed Notice (Map Amendments). Mail written notice to property owners within 200 feet of the subject site at least 11 days before the P&Z hearing, using the most recent tax roll; courtesy mailing to appraisal-district records may be added where municipal rolls do not list an owner.

- b) Published Notice (Council). Publish notice of the Council hearing in the City's official newspaper at least 16 days prior to the Council hearing.
 - c) Website. Publish notice of the Council hearing on the City's official webpage at least 16 days prior to the Council hearing.
- 2) Comprehensive Zoning Changes
- a) Published Notice (Council). Publish notice of the Council hearing in the City's official newspaper at least 16 days prior to the Council hearing.
 - b) Website. Publish notice of the Council hearing on the City's official webpage at least 16 days prior to the Council hearing.
 - c) As applicable, shall provide written notice of each public hearing regarding any proposed adoption of or change to a zoning regulation or boundary under which a current conforming use of a property is a nonconforming use if the regulation or boundary is adopted or changed. The notice must:
 - 1. Be mailed by United States mail or delivered electronically to each owner of real or business personal property where the proposed nonconforming use is located as indicated by the most recently approved municipal tax roll and each occupant of the property not later than the 10th day before the hearing date;
 - 2. Contain the time and place of the hearing; and
 - 3. Include the following text in bold 14-point type or larger:
 "THE CITY OF BASTROP IS HOLDING A HEARING THAT WILL DETERMINE WHETHER YOU MAY LOSE THE RIGHT TO CONTINUE USING YOUR PROPERTY FOR ITS CURRENT USE. PLEASE READ THIS NOTICE CAREFULLY."
- 3) Joint Hearings. P&Z and Council may hold a joint zoning hearing; statutory mailed/published notice requirements apply to joint hearings.

G. Protests & Voting Requirements

- 1) Standard Protest ("20% Rule"). If a written protest is filed by owners of: (i) 20% or more of the area of the land included in the proposed change, or (ii) 20% or more of the area of land within 200 feet of the subject area (including across streets/alleys), approval requires a three-fourths (¾) vote of all City Council members.
- 2) Pro-Housing Protest Exception. If the protest is filed only under the state's pro-housing provision (i.e., the change allows additional residential development without adding commercial/industrial uses, subject to limited first-floor retail exceptions) and meets the higher 60% protest threshold within 200 feet, approval requires a majority of all City Council members.
- 3) Unanimous P&Z Denial. If P&Z unanimously recommends denial, Council approval requires a three-fourths (¾) vote of all Council members.

- 4) Form of Protest. Protests must be written, identify the property and signer's ownership, and be filed with the City Secretary before the Council vote.
- H. Council Action, Ordinance & Effective Date
- 1) Action by Ordinance. Council may approve, approve with conditions (including adoption of Concept Plan exhibits), remand, or deny.
 - 2) Record & Map Update. The City maintains the official file (application, notices, staff report, exhibits, ordinance) and updates the Official Zoning Map accordingly.
- I. Resubmittal After Denial. A substantially similar rezoning for the same property is not accepted for 12 months following Council denial unless Council authorizes reconsideration due to substantial new or corrected information.
- J. Fees. Fees are as adopted by City Council in the Master Fee Schedule. Where specialized third-party review is necessary (e.g., traffic, environmental, legal), the City may recover actual costs from the applicant.
- K. Initial Zoning for Annexation
- 1) Purpose. Coordinate annexation and initial zoning so expectations are clear at the time of annexation while complying with state annexation and zoning procedures.
 - 2) When Allowed. The City may process a zoning map amendment for territory proposed for annexation only if an annexation petition/consent is on file and the zoning ordinance expressly states it is contingent and becomes effective only upon the annexation's effective date. No zoning is enforced before annexation.
 - 3) Submittals. In addition to Subsection D, file annexation materials required by state law and this Code. Include a contingency statement for the zoning ordinance ("effective upon annexation").
 - 4) Process & Sequence. Pre-zoning applications shall be processed in the following order:
 - a) Development Review Committee (DRC) Review. The application shall be reviewed by the DRC for completeness, consistency with adopted plans, and compliance with applicable regulations.
 - b) Director Recommendation. Following DRC review, the Director shall prepare a written recommendation and forward it to the Planning and Zoning Commission.
 - c) Planning and Zoning Commission Hearing and Recommendation. The Planning and Zoning Commission shall hold a public hearing on the proposed zoning and shall make a recommendation to the City Council.
 - d) City Council Hearing. The City Council shall hold a public hearing on the proposed zoning. The Council may consider the annexation ordinance and the contingent zoning ordinance for the same property at the same meeting.
 - (1) Order of votes and effective date. The City Council shall vote on and approve the annexation ordinance prior to voting on the contingent zoning ordinance. Any contingent zoning ordinance adopted for the property shall not take effect, and shall have no force, unless and until the annexation ordinance becomes effective and the property is within

the City limits. If the annexation ordinance is not adopted or does not become effective, the contingent zoning ordinance is void.

- 5) Notices (Zoning Item). Provide mailed and published notices per Subsection H; joint hearings are allowed. School-district or special notices apply if and as required by law.
- 6) Approval Criteria (Zoning Item). In addition to Subsection F, the City shall find the rezoning feasible with annexation service assumptions and enforceable post-annexation.
- 7) Effect of Annexation on Uses. Annexation does not prohibit continuation of certain existing or planned uses as protected by state law.
- 8) Record & Map Update. Upon annexation's effective date, record both ordinances and update the Official Zoning Map and the Future Land Use Map.
- 9) Any territory annexed into the City of Bastrop not otherwise accompanied by a separate zoning application and procedure, shall be classified as RR (Rural Residential) Zoning until another zoning is established by the City Council.

Sec. 14.13.003 Administrative Relief.

- 1) Purpose. Provide a streamlined, context-sensitive, staff-level process—administered by the Development Review Committee (DRC)—to approve minor adjustments to quantitative standards in this Chapter.
- 2) Authority.
 - a) The DRC is the final administrative decision-maker for requests under this section when submitted with a Site Plan.
 - b) If no Site Plan is required, the Planning Director (or designee), acting as DRC's delegate, may render the decision under the same criteria and limits.
- 3) Administrative Relief is not a variance and does not authorize any change of use or relief from non-quantitative standards.
- 4) Scope of Eligible Standards.
 - a) The DRC may approve an adjustment of up to ten percent (10%) to any numerical standard in the Bastrop Development Code, excluding maximum lot coverage/impervious cover requirements.
 - b) Rounding: Round to nearest whole number, whole foot, whole square foot, or whole percent.
 - c) Cumulative limit: multiple approvals may occur on a site, but no single standard may be adjusted by more than 10% under this section.
- 5) Ineligible Items. Administrative Relief may not: (1) authorize a use not permitted; (2) reduce standards established by a PD ordinance or Development Agreement; (3) waive building/fire/drainage/access/life-safety requirements; (4) permit encroachments into rights-of-way, easements, required buffers, or sight triangles; (5) approve an increase in maximum impervious/lot coverage requirements; (6) approve any adjustments to the requirement of Tree Mitigation.

- 6) Approval Criteria. The DRC or Director shall make written findings that:
 - a) Intent & Equivalent Performance. The request meets the stated purpose of the Bastrop Development Code and the purpose of the applicable section and provides equal or better performance, and does not authorize a prohibited use or increase base entitlements.
 - b) The approval of the request will result in a development that would be compatible with surrounding land uses and harmonious with the public interest.
 - c) Minimum Necessary. The deviation is the least departure practicable to achieve the Code's intent, and the amount of relief is expressly quantified.
 - d) No Material Adverse Impacts / Code Compliance. The request will not create material adverse effects on health/safety, traffic/queuing, access, drainage/flood risk, utilities, or neighboring properties and complies with all life-safety codes (Building, Fire, TDLR/ADA, floodplain).
 - e) Plan Consistency & Compatibility. The outcome is consistent with the Comprehensive Plan and adopted master plans and remains compatible with surrounding development and streetscape.
- 7) Submittal.
 - a) Include on the Site Plan cover sheet a "Administrative Relief Table" listing: the standard, code citation, base requirement, requested percentage/amount, and resulting dimension.
 - b) Show easements, utilities, trees/CRZs, and visibility triangles on the Site Plan to confirm no conflicts.
 - c) No separate application or fee is required when submitted with a Site Plan.
- 8) Procedure & Decision
 - a) Timing: Reviewed concurrently with the Site Plan; completeness and review cycles follow the Site Plan timeline.
 - b) Decision: The DRC issues a written decision (approval, approval with conditions, or denial) documented in the Site Plan decision letter and noted on the approved plans.
 - c) Conditions: The DRC may impose conditions (e.g., façade alignment, porch depth, utility adjustments, landscape placement) to ensure compliance with criteria.
 - d) Record: Approved dimensions and any contextual setback line shall be labeled on the Site Plan and reflected on building permit drawings.
 - e) Appeals. Any person aggrieved by a decision under this section may appeal to the Zoning Board of Adjustment within 15 calendar days of the decision letter. The ZBA reviews de novo for compliance with this section.
- 9) Expiration.
 - a) When bundled with a Site Plan: relief expires with the Site Plan approval. Extensions mirror Site Plan extension provisions.

- b) When approved outside a Site Plan: relief expires 12 months after approval unless a building permit is issued; the Director may grant a single 6-month extension for good cause.
 - c) When a site plan is amended, any previously granted administrative relief may be subject to re-review.
- 10) Relation to Nonconformities. May not expand a lawful nonconforming use or structure, except that contextual front-setback alignment may be used to bring a nonconforming front setback closer to conformity.
- 11) No Precedent. Each approval is site-specific and does not create a precedent.

Sec. 14.13.004 Site Development Plans.

A. Purpose & Applicability

- 1) Purpose. Ensure new development is safe, serviceable, and compatible by verifying compliance with this Code, adopted plans, and applicable engineering, utility, fire, and building standards.
- 2) When Required. A Site Plan is required prior to building permit for:
 - a) New nonresidential buildings;
 - b) Multifamily (3+ units), townhomes, and mixed-use buildings;
 - c) Exterior additions or intensifications that (i) add $\geq 1,000$ sq ft GFA or $\geq 10\%$ (whichever is greater), (ii) add/relocate driveways, fire lanes, or loading, or (iii) expand parking by ≥ 10 spaces;
 - d) Changes of use that increase parking demand, traffic, outdoor activity, or life-safety risk;
 - e) New/expanded outdoor storage, vehicle display/queuing, or fuel service;
 - f) Projects in an overlay when that overlay requires a Site Plan.
- 3) Exemptions. Not required for:
 - a) Single family dwellings or duplex's on individual platted lots (frontage/driveway items still shown with the building permit);
 - b) Interior finish-out and ordinary repairs that do not increase occupancy load, parking demand, or external impacts;
 - c) Very small exterior changes (<1,000 sq ft) with no new access points and no triggers in A(2).
The Director may require a Site Plan where otherwise exempt work creates traffic, drainage, fire access, or compatibility concerns.

B. Relationship to Other Approvals

- 1) Zoning first. Uses must be permitted or conditionally approved (CUP/PD). Site Plans implement—not replace—those approvals and conditions.
- 2) Deviations. Relief from standards follows the applicable procedure (Administrative Relief, BOA variance, or Council Alternative Compliance) before or concurrent with Site Plan review.

- 3) Public Improvement Plans (Construction Plans). Site Plan approval is distinct from civil construction drawing (PIP) approval; both may be required where public/frontage improvements or utility extensions are proposed.
 - 4) Overlay/Plat/Historic. COA, floodplain/WUI, plats, and similar approvals are conditions of Site Plan approval when applicable.
- C. Submittal (Minimum)
- 1) Pre-application meeting required.
 - 2) Application with:
 - a) Site layout (buildings, setbacks, easements, access, internal circulation, fire lanes, loading, refuse/mechanical, outdoor activity areas) and a compliance table;
 - b) Parking/loading plan (counts, accessible & bicycle spaces, geometry);
 - c) Access & Connectivity sheet (driveway spacing/sight distance, cross-access, sidewalks/trails, pedestrian routes/ramps);
 - d) Landscape and Irrigation plans sealed by a Landscape Architect
 - e) Tree survey performed by an ISA Certified Arborist and accompanying preservation/mitigation plan;
 - f) Utilities (domestic, fire, wastewater) and will-serve/availability as needed;
 - g) Drainage concept (ponds/outfalls and pre/post summary);
 - h) Lighting/photometric plan where outdoor lighting or nighttime hours are proposed;
 - i) Building elevations or massing sufficient to verify height, screening, and transparency;
 - j) TIA/traffic study, if required;
 - k) Phasing and timing of frontage/public improvements;
 - l) Overlay documentation, if applicable.
 - m) Site development plan checklist complete, along with all items required by the checklist.
- D. Review & Decision
- 1) Completeness check. Incomplete applications are returned with deficiencies.
 - 2) DRC review. Consolidated technical review and comments.
 - 3) Director decision (administrative). Approve, approve with conditions, or deny. No public hearing.
 - 4) Conditional approvals. May be issued contingent on obtaining related approvals (CUP, Alternative Compliance, ZBA variance, plat, COA, floodplain permit) prior to permit issuance.
 - 5) Resubmittal. Applications may be remanded for revisions where material issues remain.
- E. Standards for Approval (Findings). The Director shall approve only if the Site Plan:
- 1) Complies with district standards, permitted uses, and any CUP/PD/overlay conditions;
 - 2) Meets Access & Connectivity standards (safe driveway placement, internal circulation, pedestrian connections, cross-access where required);

- 3) Provides required parking, loading, stacking, and bicycle parking (including any approved shared/remote arrangements);
 - 4) Meets Landscaping & Tree Preservation requirements, including screening of service/outdoor storage and protection/mitigation of significant trees;
 - 5) Demonstrates adequate utilities, fire protection, and stormwater management consistent with City engineering criteria and adopted plans;
 - 6) Protects adjacent properties through buffers, lighting control, and orientation of access/service areas;
 - 7) Avoids unsafe traffic conditions or undue congestion and implements proportionate off-site mitigation when required;
 - 8) Meets all other applicable provisions of this Code.
- F. Conditions of Approval. The Director may impose conditions reasonably related to compliance and mitigation, including: access management (location/closure/turns/cross-access/TDM), frontage improvements (sidewalks/trees/lights/ramps) tied to CO timing, screening/landscape/tree measures, limits on outdoor activity/queuing/delivery windows, drainage/utility upgrades and easements, phasing, and performance security for public improvements.
- G. Site Plan Amendments & Compliance Triggers
- 1) When an Amendment is Required. Amend before changes that would:
 - a) Alter building footprint, placement, or height;
 - b) Add floor area, outdoor activity, loading/queuing, or fuel service;
 - c) Add, remove, or relocate a driveway, fire lane, or loading space;
 - d) Reconfigure internal circulation, parking layout, stall/aisle geometry, or accessible/bicycle parking;
 - e) Modify drainage facilities, detention/retention, outfalls, or utility routing;
 - f) Change the use (or mix) in a way that increases trips, parking demand, hours, or external impacts;
 - g) Affect compliance with any condition of a CUP/PD/Alternative Compliance or any overlay approval.
 - 2) Changes Not Requiring an Amendment (As-Builts). De minimis “field changes” for constructability that do not reduce any standard or condition, such as: minor utility alignment shifts; like-for-like plant substitutions; small door/window shifts not affecting transparency or fire ratings; converting up to five (5) striped spaces to compact where allowed. Note on as-builts before final inspection/CO.
 - 3) Cumulative Changes. Amendment thresholds apply cumulatively within 24 months.
 - 4) Compliance with Current Code.
 - a) Changed elements must comply with current standards (access/connectivity, parking/loading, landscaping/trees, lighting, overlays).
 - b) Unchanged elements may remain as legally conforming under prior approval unless G(5) requires broader upgrades.

- c) Existing CUP/PD/Alternative Compliance conditions remain in effect unless separately modified by the appropriate body.
 - 5) Proportionality & Alternatives. Upgrades must be roughly proportionate to the amendment’s impacts. Where strict application is infeasible due to utilities, trees, or topography, the City Manager may approve a targeted compliance plan if the result meets the Code’s intent equal or better.
 - 6) Submittal & Effect. Submit clouded changes with a short narrative addressing G(4)–G(6) and any updated sheets limited to the changed scope. An approved amendment supersedes prior approval only for modified sheets/areas; other areas remain under the last unamended approval.
- H. Expiration & Extensions
- 1) Expiration. A Site Plan expires two (2) years from approval if no building permit is issued and under active construction, unless otherwise specified in the approval.
 - 2) One extension. The Director may grant one extension up to six (6) months for good cause.
 - 3) Effect of expiration. Permits may not be issued until a new or amended Site Plan is approved.
- I. Appeals. An appeal of the Director’s administrative decision (original or amended Site Plan) follows Sec. 14.12.008 Appeals of Administrative Decisions. An appeal stays the decision unless the Director certifies that a stay would cause imminent peril.
- J. Effect of Approval. Approval authorizes submittal of construction drawings and building permits consistent with the Site Plan. Approval runs with the land and binds successors, subject to conditions and expiration.
- K. Administrative Checklist (Informational)
- The Director shall maintain a Site Plan checklist consistent with this section that identifies required sheets/studies, acceptable formats, and triggers for TIA, photometric, floodplain/WUI, and tree preservation submittals.

Sec. 14.13.005 Conditional Uses.

- A. Purpose & Applicability
- 1) Purpose. Provide a public review process for certain uses that may be appropriate in a zoning district only if tailored to the site and context through conditions to ensure compatibility and protection of public health, safety, and welfare, consistent with Texas Local Government Code Ch. 211.
 - 2) Applicability. A CUP is required for any land use identified as “C” (Conditional) in the Table of Permitted Uses, and as otherwise specified in this Code.
 - 3) PD/Planned Development Relationship. In a PDD, a use that is conditional in the comparable base district may be allowed only if specifically identified in the adopting PD ordinance; otherwise, a CUP is required.
- B. Effect of Approval
- 1) A CUP authorizes the use only on the specific property and in the manner approved, subject to all conditions of approval and all other applicable codes.

- 2) A CUP runs with the land and is binding on the property, not the owner. A CUP remains valid upon sale, conveyance, or other transfer of the property, and applies to all subsequent owners, tenants, and occupants, unless modified, revoked, expired, or otherwise terminated in accordance with this Code.

C. Application Submittal

- 1) Pre-application. A pre-application meeting with the Director/DRC is strongly encouraged to scope submittals and issues. (Bodies and processes referenced in existing administration sections and flowchart.)
- 2) Minimum contents. Applications must include:
 - a) Site plan with building/location layout, access/parking/loading, screening/buffering, and outdoor activity areas.
 - b) Operations plan (hours, capacity, deliveries, special events, alcohol, outdoor sound/lighting).
 - c) Impact memo(s) proportionate to the proposal (traffic circulation/parking, utilities/drainage, noise/odor/light, environmental constraints, adjacency).
 - d) Narrative addressing the approval standards in Subsection F.
 - e) Owner authorization and required fees.
 - f) Any overlay/district compliance documentation, if applicable.

D. Completeness & DRC Review

- 1) Completeness. The Director determines administrative completeness and schedules interdepartmental DRC review.
- 2) DRC Recommendation. The DRC provides a consolidated technical review and recommends approval, approval with conditions, or denial to the Director.

E. Public Notice & Hearings

- 1) Notice. Public notice and hearing are required in accordance with state law and this Code for zoning decisions of this type.
- 2) Hearings. The Planning & Zoning Commission holds a public hearing and makes a recommendation; City Council acts after public hearing.

F. Standards for Approval (Findings). City Council may approve a CUP (with or without conditions) only on finding that the application:

- 1) Is consistent with the Comprehensive Plan and the stated purpose of the zoning district.
- 2) Is compatible with and not detrimental to adjacent properties, considering building scale, site layout, hours, intensity, and expected external effects (noise, vibration, dust, odor, glare, traffic, on-street parking).
- 3) Provides adequate access, circulation, parking, and loading without creating unsafe conditions or undue congestion on the transportation network.

- 4) Is served by, and will not overburden, public facilities and services (water, wastewater, drainage, police/fire/EMS), with any necessary improvements or phasing secured by conditions.
- 5) Provides appropriate screening, buffering, lighting control, and site/operational measures to mitigate off-site impacts—especially where the site adjoins residential or P/OS districts.
- 6) Complies with all applicable overlay standards, adopted master plans, and other provisions of this Code.
- 7) Will not result in a material adverse cumulative effect in combination with other approved conditional uses in the area.

G. Conditions of Approval

- 1) City Council may impose conditions reasonably related to mitigating potential adverse impacts and ensuring compliance with this Code and the approval standards above, including but not limited to:
 - a) Limits on hours of operation; event frequency; occupancy/capacity; or outdoor activity.
 - b) Site design features (building placement or orientation; fence/wall/landscape screening; preservation of significant trees or natural features).
 - c) Operational controls (delivery windows, waste management, sound/lighting plans, security).
 - d) Transportation/parking measures (shared or remote parking approvals, TDM measures, access restrictions, driveway location, required cross-access).
 - e) Infrastructure/drainage improvements or phasing tied to certificates of occupancy.
 - f) Time limits (including trial periods), reporting, compliance reviews, or renewal triggers.
- 2) Conditions must be stated on the record and reflected on the approved site plan or letter of approval.

H. Decision & Record

- 1) P&Z Commission: recommendation to approve, approve with conditions, or deny.
- 2) City Council: approval, approval with conditions, denial, or remand for additional information.
- 3) The decision and all conditions shall be documented in the approval letter and/or on the stamped site plan kept in the development file.

I. Amendments to an Approved CUP

- 1) Minor Modifications (Administrative). The Director may approve modifications that do not increase external impacts or intensity (e.g., shifts internal to the site that maintain approved buffers/setbacks; minor changes to floor area under 10%; clarifications to management plans).
- 2) Major Modifications. Any other change—especially increases to hours, occupancy, outdoor activity areas, new driveways, or reductions in approved buffers—requires a new CUP amendment following the same procedures as the original approval.

J. Continuation and Revocation

- 1) Continuation. A CUP does not expire solely due to the passage of time. A CUP remains in effect unless modified, revoked, or otherwise terminated in accordance with this Code or the conditions of approval.

- 2) Establishment of Use. If a CUP is approved for a use or development that requires a building permit or other City approval, the applicant shall diligently pursue the required permits and approvals. The City may require periodic status updates as a condition of approval, but lack of progress alone shall not terminate the CUP unless an express condition of approval provides otherwise.
 - 3) Revocation. Following notice and public hearing, City Council may revoke a CUP for substantial noncompliance with the approved plan or conditions, or for repeated, documented violations that materially harm the public health, safety, or neighboring properties. The Planning and Zoning Commission may provide a recommendation prior to Council action. The process may be initiated by the City and shall follow the same notice and public hearing requirements as established in Sec. 14.12.003(E).
- K. Relationship to Other Approvals
- 1) A CUP is not a variance; dimensional relief follows the applicable administrative relief/alternative compliance/variance procedures in this Code.
 - 2) Where a use requires both a CUP and another approval (e.g., site plan, COA, subdivision, building permit), the CUP may be conditioned on obtaining and complying with those approvals.
 - 3) If a PD ordinance specifically lists a use as allowed, a separate CUP is not required unless the ordinance says otherwise.
- L. Re-Application After Denial. An application that is substantially the same as a denied CUP may not be resubmitted for six (6) months unless the Director finds there is a material change in circumstances or the proposal has been materially revised to address prior reasons for denial.
- M. Table Linkage & Interpretation. Where the Table of Permitted Uses labels a use as “C,” a CUP is required in that district. If a use is not listed, the Director shall interpret the use per the procedures in this Article.

Sec. 14.13.007 Filing & Notice Requirements.

- A. Applicability.
This section governs filing and public notice for zoning matters processed under this Article, including but not limited to zoning map amendments, Conditional Use Permits (CUPs), and text amendments.
- B. Filing.
- 1) Applications must be submitted on City forms with required attachments and fees
 - 2) The Director shall conduct a completeness review and schedule items to meet the minimum state notice timelines.
 - 3) Submittal calendars and technical filing requirements may be established by administrative policy.
- C. Required Notice.

- 1) Zoning Regulations & District Changes. Published and written notice shall be provided as required by Texas Local Government Code Chapter 211, as amended (including notice for Planning & Zoning Commission hearings and City Council hearings).
- 2) Initial Zoning of Annexed Areas. Notice shall follow Texas Local Government Code Chapters 43 and 211, as applicable.
- 3) Subdivision and Related Actions. Where notice is required for subdivision actions governed by this Code, notice shall follow Texas Local Government Code Chapter 212, as applicable.
- 4) Open Meetings. All meetings and notices shall comply with the Texas Open Meetings Act (Texas Government Code Chapter 551).
- 5) Where this Code imposes notice in addition to, or more stringent than, state law, the City shall provide the greater notice.
- 6) City Council Adopted Notification Requirements:

	Published Notice	Personal Notice	Posted Notice
Notification Location	Newspaper & Website	United States Mail	Subject Property
Time Before Set Hearing	16 days	A. General: 11 days B. Comprehensive Plan or Zoning change: 11 days	A. General: 11 days B. Comprehensive Plan or Zoning change: 11 days

Include in Notice	<p>A. Date, time, and location of hearing;</p> <p>B. Purpose of the hearing; and</p> <p>C. Identification of the subject property if the decision concerns an individual tract or parcel of land.</p>	<p>A. Name of the applicant;</p> <p>B. Date time, and location of the hearing;</p> <p>C. Purpose of the hearing;</p> <p>D. Identification of the subject property; and,</p> <p>E. The name of the appellant if an appeal.</p>	<p>A. Purpose of the request; and</p> <p>B. All public hearing dates.</p>
Notification Instructions	<p>Development Services Department will be responsible for posting the notice in the newspaper of general circulation.</p>	<p>A. Each owner of real property located within two hundred (200) feet of the exterior boundary of the property in question and any other persons deemed by the Lead Officer or decision-maker to be affected by this application;</p> <p>B. The applicant and/or property owner; and</p> <p>C. The appellant if an appeal.</p>	<p>A. Minimum 2’x4’ sign placed on the street frontage in visible unobstructed location.</p> <p>B. Utilize a minimum 6” lettering.</p> <p>C. Shall stay in place until final action is taken or request is withdrawn</p>

7) City Council Adopted Development Approval Process:

Action		Meeting Type		Committees			
R	Review/ Recommend	PM	Public Meeting	ZBA	Zoning Board of Adjustments	Y	Required

D	Decision	PM*	May Require Initial Authorization	P&Z	Planning & Zoning Commission	N	Not Required
A	Appeal	PH	Public Hearing	CC	City Council		

Approval Process	Review and Approval Authority			Notice				
	Source	ZBA	P&Z	CC	Application Notice	Published Notice	Personal Notice	Posted Notice
Legislative								
Comprehensive Plan Map and Text Amendment			R/PH/PM	D/PH/PH/PM	Y	Y	Y	Y
Zoning Code Text Amendment			R/PH	D/PH/PM	Y	Y	N	N
Zoning Map Amendments			R/PH	D/PH/PM*	Y	Y	Y	Y
Variance/Administrative Appeal	D/PH/PM				Y	N	Y	Y
Conditional Use Permits			R/PH/PM	D/PH/PM*	Y	Y	Y	Y

D. Method & Responsibility

- 1) Published notice shall be placed in the City’s official newspaper as required by state law.
- 2) Written notice (if required by state law) shall be mailed to the parties and within the distances prescribed by state law, using the most recent county appraisal district records or other method allowed by law.
- 3) If a case is continued, re-notice shall be provided when and as required by state law.

Sec. 14.13.008 Public Hearing Procedures.

A. Planning & Zoning Commission (Recommendation)

The Commission shall hold a public hearing and make a recommendation to City Council on zoning matters in accordance with Texas Local Government Code §211.007 and related provisions, as amended, and the Texas Open Meetings Act.

B. City Council (Decision)

City Council shall hold a public hearing and take action in accordance with Texas Local Government Code §211.006 and related provisions, as amended, and the Texas Open Meetings Act.

C. Protest/Supermajority

When a valid protest is filed in the manner provided by Texas Local Government Code §211.006(d)–(f), Council’s voting threshold shall follow state law.

D. Conduct of Hearings; Rules of Procedure

Hearings shall be conducted under Council-adopted or Commission-adopted rules of procedure, provided those rules are consistent with Texas law. Ex parte communications, evidentiary submittals, and continuances shall be handled in a manner consistent with due process and the Open Meetings Act.

E. Conflicts

If a conflict exists between this Code and state law, state law governs.

Sec. 14.13.009 Fees.

A. Fee Schedule

All application, notice, recording, and related fees for procedures under this Article shall be as adopted in the City’s Master Fee Schedule.

B. Third-Party Costs

Applicants are responsible for third-party costs reasonably incurred by the City to process an application (e.g., legal notices, outside technical review), when authorized by the Master Fee Schedule.

C. Waivers/Refunds

Any waiver, reduction, or refund of fees shall be as provided in, and administered under, the Master Fee Schedule and applicable City policies.

ARTICLE 14.14 DEFINITIONS

Sec. 14.14.001 Purpose; Use of Definitions.

- A. Purpose. This Article provides common meanings for terms used throughout this Code to ensure consistent application and administration.
- B. Controlling Law. Where a term is defined by state or federal law (e.g., manufactured housing, community homes, floodplain terms), that legal definition controls in the event of a conflict.
- C. Cross-References. Unless otherwise stated, references to City boards, officers, and procedures are those established in Article 14.12 (Administration and Procedures) and Article 14.11 (Zoning Board of Adjustment).
- D. Interpretation Rules.
 - 1) "Shall" is mandatory; "may" is permissive.
 - 2) Singular includes the plural and vice versa.
 - 3) Terms not defined herein shall be given their ordinary meaning within the context of this Code or defined by the Director.
- E. Abbreviations.

ADA – Americans with Disabilities Act;

BFE – Base Flood Elevation;

CFR – Code of Federal Regulations;

COA – Certificate of Appropriateness;

CUP – Conditional Use Permit

EC – Employment Center;

ETJ – Extraterritorial Jurisdiction;

FAR – Floor Area Ratio;

FIRM – Flood Insurance Rate Map;

GC – General Commercial

GFA – Gross Floor Area;

HRC – Texas Human Resources Code;

IC – Impervious Cover;

IND - Industrial

MF – Multi-Family;

MU – Mixed Use;

PDD – Planned Development District;

PI – Public Institutional
P/OS – Parks and Open Space;
RR – Rural Residential;
SF – Single-Family;
SFHA – Special Flood Hazard Area;
TAS – Texas Accessibility Standards;
TDLR – Texas Department of Licensing & Regulation.

F. Definitions

Accessory Building/Structure. A subordinate, non-habitable building or structure on the same lot as the principal building, customarily incidental to the principal use (e.g., detached garage, shed).

Accessory Dwelling Unit (ADU). A subordinate dwelling unit on the same lot as a principal dwelling that provides complete, independent living facilities (sleeping, cooking, and sanitation).

Accessory Use. A use that is incidental and customarily associated with, and located on the same lot as, a principal use.

Administrative Relief (Minor). A DRC or Director-approved minor adjustment to a quantifiable standard (e.g., up to 10% variation from a numeric requirement) where equal or better compliance with the Code purpose is demonstrated, and where expressly allowed by this Code.

Agricultural Operation – General. A use, facility, or activity that meets the definition of an “agricultural operation” under Texas Agriculture Code Section 251.002, as amended. This includes, but is not limited to, the cultivation or production of crops, forage, or horticultural products; the raising or keeping of livestock or poultry and the production of livestock or poultry products; beekeeping and apiaries; aquaculture; and related on-site practices and improvements that are commonly and historically associated with such activities. Where this Code uses the term “Agricultural Operation – General,” it is intended to be interpreted consistently with Texas Agriculture Code Chapter 251 and Article I, Section 36 of the Texas Constitution (Right to Farm).

Alley. A public or private vehicular passage providing secondary access to the side or rear of lots, not intended for primary frontage.

Apiary (Beekeeping). The keeping, raising, or management of honeybee colonies in hives or similar structures for the production of honey, beeswax, pollination, or related purposes. An Apiary may be operated as an accessory use to a residential or agricultural use or as a principal use where permitted, and is subject to numeric limits, setback requirements, and management standards specified by this Code to address safety and compatibility.

Applicant. The property owner or authorized agent submitting an application under this Code.

Aquaculture, Small-Scale (Non-Industrial). The cultivation, rearing, or propagation of fish, shellfish, aquatic plants, or other aquatic organisms in tanks, ponds, or similar facilities on a scale that is subordinate to the primary use of the property and is not an intensive, industrial, or large-scale commercial operation. Small-Scale Aquaculture may include on-site harvesting and limited direct sales where permitted, but does not include large processing plants, hatcheries, or high-intensity industrial aquaculture operations.

Average Grade Plane (AGP). The arithmetic mean of finished ground elevations measured 6 ft perpendicular to the midpoint of each exterior wall of the building, excluding unenclosed projections (porches, decks, stoops). If finished grade varies from pre-construction natural grade by >3 ft along >50% of the perimeter, the Director may require using natural grade to establish AGP.

Awning Sign. Shall mean a sign placed on a cloth, plastic, canopy, or other nonstructural covering that either is permanently attached to a Building or can be raised or retracted to a position against the Building when not in use.

Backyard Livestock (Small Animals). The keeping of small, non-commercial livestock or fowl as an accessory use to a permitted residential use on the same lot, including but not limited to hens (excluding roosters), ducks, rabbits, and similar small animals, in numbers and under conditions specified by this Code. Backyard Livestock is intended for personal use, education, or limited household-scale egg, meat, or fiber production and does not include larger livestock such as cattle, horses, sheep, or swine, or any activity operated as a commercial animal production enterprise.

Banner Sign. A sign made of fabric, vinyl, plastic, or other flexible material that is mounted, hung, suspended, or otherwise attached to a building, fence, or structure, with or without a rigid frame, and that is not permanently affixed as a wall sign.

Bandit Sign. A small, typically temporary sign that is placed without authorization on public property or within the public right of way, or attached to utility poles, traffic control devices, medians, or similar locations where signs are prohibited.

Blade Sign. A projecting sign that is attached to a building wall and projects outward, so the sign face is generally perpendicular to the building facade.

Base Flood; Base Flood Elevation (BFE). The flood with a 1% annual chance of being equaled or exceeded (commonly, the “100-year flood”) and the water-surface elevation associated with that flood, as defined by the National Flood Insurance Program (NFIP).

Build-To Line (BTL) / Build-To Zone (BTZ). A required line or range between a minimum and maximum setback along a street frontage where a specified percentage of a building façade must be placed to establish a consistent street edge.

Building. A structure with a roof supported by columns or walls, used or intended for supporting or sheltering any use or occupancy.

Building Coverage. The horizontal area of a lot covered by the footprint of roofed structures, measured to the exterior walls.

Building Height. The greatest vertical distance from the Average Grade Plane (AGP) (or, within the Special Flood Hazard Area, the Design Flood Elevation) to the highest roof point (ridge) or, for flat roofs, the top of parapet (or roof deck if none). Excluded: parapets ≤ 4 ft, chimneys, flues/vents, solar equipment/racking, mechanical equipment and required screening, and elevator/stair overruns ≤ 10 ft.

Building Wall Sign. A sign attached to, painted on, or erected against the exterior wall of a building with the sign face in a plane generally parallel to the wall. This includes painted wall signs, graphic wall signs, and signs on a wall mounted panel.

Caliper (Tree). The diameter of a tree trunk measured four and one-half (4.5) feet above grade (DBH).

Civic Use. Use of land or buildings by a governmental, educational, or nonprofit entity for civic purposes (e.g., schools, libraries, public safety facilities).

Commercial Message. Any text, logo, trademark, service mark, slogan, URL, QR code, phone number, social media handle, product name, service description, pricing, call to action, or other identifier that promotes, advertises, or directs attention to a business, product, service, or event for commercial purposes.

Commercial Wall Graphic. A mural or wall graphic that includes a Commercial Message, or that is determined by the Director to function primarily as on premises advertising. A Commercial Wall Graphic is regulated as a building wall sign.

Community Garden (Non-Commercial). A shared open space where fruits, vegetables, herbs, flowers, and similar plants are grown and maintained by a group of individuals, households, or an organization for personal use, donation, or educational purposes. A Community Garden may be publicly or privately owned, may include common tool storage, seating, and educational areas, and may allow incidental cost-sharing among participants, but does not include on-site retail sales to the general public or primary income-generating activity.

Community Home. A community-based residential home serving persons with disabilities that meets the qualifications of Texas Human Resources Code Chapter 123; such homes are protected uses subject to state limitations.

Comprehensive Plan. The City's adopted long-range policy document, including maps, goals, and implementation actions, as amended.

Conditional Use Permit (CUP) / Special Use Permit (SUP). A discretionary permit authorizing a specific use in a district subject to conditions to ensure compatibility with surrounding areas.

Construction / Development Sign. Shall mean a Commercial Sign placed on a piece of property advertising planned construction and providing related information, including but not limited to the name of the contractor, the name of the owner, the planned date of completion, and information indicating the future use or occupation of the Site.

Contractor Shop with Outdoor Yard. A building, structure, and/or lot used by a construction, building service, trade, or similar contractor for the storage, dispatch, staging, loading/unloading, and minor maintenance of vehicles, trailers, tools, equipment, and materials used in the contractor's operations, with an accessory outdoor yard area used for storage or staging. May include accessory administrative office space directly supporting the contractor operation. This use does not include:

- 1) Retail sales to the general public as a primary use,
- 2) Manufacturing as a primary use,
- 3) Junk or salvage yards,
- 4) Bulk storage of waste materials, or

-
- 5) A public or private Utility Shop / Storage facility operated by a utility provider.

Outdoor Storage / Equipment. The keeping, storing, staging, parking, or stockpiling of materials, supplies, equipment, or commercial vehicles outdoors, whether on the ground, racks, trailers, or similar, as a primary use or as an accessory use to a principal use, where the outdoor area is intended to be used for storage or staging on a recurring or long-term basis. This includes, by example, outdoor storage of construction materials, pallets, pipe, landscape materials, equipment (such as skid steers, excavators), and commercial fleet vehicles or trailers when stored outside of an enclosed building. This use does not include:

- 1) Display of merchandise for retail sales that is otherwise allowed and regulated as an outdoor display,
- 2) Temporary construction staging occurring under an active building permit, or
- 3) Temporary loading/unloading in the normal course of business.

Design Flood Elevation (DFE). The Base Flood Elevation (BFE) plus required freeboard, as adopted in the City's Flood Damage Prevention Ordinance.

Director. The Director of Development Services or designee.

Drive-Through Facility. A facility providing goods or services to occupants of vehicles in stacked lanes and service windows; see stacking standards in Article 14.04.

Duplex. A single building on one lot containing two principal dwelling units.

Dwelling Unit. A residential unit providing complete, independent living facilities, including provisions for living, sleeping, eating, and cooking.

Electronic Sign. Shall mean any Sign that the text, letters, numbers, pictures, or symbols forming the informational portion of the Sign consists of flashing, intermittent, or moving lights, including any LED screen or any other type of video display. Illumination of a Sign, by itself, does not create an Electronic Sign.

Employment Center (EC). The zoning district intended for employment-generating, industrial, and logistics uses as defined in Article 14.02.

Façade. The exterior wall of a building facing a public right-of-way or primary frontage.

Farm Stand (On-site Sales of Farm Products). A small-scale, fixed or temporary structure or display area located on a site where agricultural products grown or produced on that site or on other local farms are sold directly to consumers. A Farm Stand is typically operated by the owner or operator of the agricultural use, may include pre-packaged or value-added products derived from farm products, and is subordinate to an on-site or nearby agricultural operation. A Farm Stand does not include multiple independent vendors or festival-type activities.

Farmers Market (Seasonal / Periodic). A recurring, organized gathering of multiple vendors or producers at a designated location where agricultural products, value-added food products, and related goods are sold directly to consumers from individual stalls, booths, or vehicles. A Farmers Market is typically seasonal or periodic in nature, may include limited prepared food and artisan goods, and may include live entertainment and related activities as allowed by permit. A Farmers Market is distinct from a Farm Stand, which is operated by a single farm or producer.

Feather Banner. Shall mean a Sign that is constructed of lightweight material (such as cloth, canvas, or vinyl) affixed to a pole or Building that is similar to a flag, except that it is longer than it is wide. A Feather Banner resembles a feather, in that it is tall and narrow, having more surface area vertically than horizontally when fully extended.

Floor Area, Gross (GFA). The total enclosed floor area of all stories of a building measured to the outside surface of exterior walls, excluding areas explicitly exempted by this Code (e.g., certain parking areas if specified).

Floor Area Ratio (FAR). The ratio of a building's gross floor area to the area of the lot.

Forage / Pasture Production (Vegetation for Animal Feed, Livestock Forage, or Wildlife Forage). The growing or harvesting of grasses, forbs, legumes, hay, or other vegetation primarily for animal feed, livestock forage, or forage for wildlife management, whether for use on-site or off-site. Forage / Pasture Production may occur as a principal use of land or as an accessory component of another agricultural operation and does not, by itself, include the keeping or grazing of animals. Forage / Pasture Production is recognized as an agricultural operation for purposes of Texas Agriculture Code Chapter 251.

Freestanding. shall mean a that is not attached to a wall or Building. A Sign that is supported by a Structure primarily designed for display of the Sign.

Frontage. The length of a lot line abutting a public street right-of-way.

General Crop Production (Non-Forage, Commercial Scale). The cultivation, growing, and harvesting of fruits, vegetables, nuts, grains, fiber crops, nursery stock, flowers, and other plant products for sale, distribution, or other commercial purposes, but does not include Forage / Pasture Production as defined in this Code. General Crop Production may occur in open fields or in structures such as greenhouses or hoop houses and may include on-site storage and handling of crops and equipment, but does not include on-site processing facilities beyond basic cleaning, sorting, and packing.

Hanging Sign. Shall mean a that is affixed to the underside of a roof, canopy, awning, or porch.

Home-Based Business. A business operated from a residential property by the owner or tenant for the purpose of manufacturing, providing, or selling a lawful good or providing a lawful service.

Home Garden (Accessory to a Residential Use). The cultivation of fruits, vegetables, herbs, flowers, and similar plants for personal use or consumption by the occupants of a dwelling on the same lot. A Home Garden is an accessory use to a permitted residential use, is not open to the general public, and does not include on-site retail sales to the general public or the keeping of livestock or poultry other than as allowed under Backyard Livestock (Small Animals).

Impervious Cover (IC). The portion of site area that prevents water infiltration (e.g., roofs, driveways, patios, paving), measured per this Code's method.

Intersection Sight Triangle. A triangular area at street or driveway intersections kept clear of visual obstructions to ensure safe sight distance, as defined by this Code's visibility standards.

Lot. A platted parcel or tract of land under single ownership having frontage on a public right-of-way, intended as a unit for transfer or development.

- **Corner Lot:** A lot abutting two intersecting streets.
- **Interior Lot:** A lot with frontage on one street.
- **Through Lot:** A lot with frontage on two roughly parallel streets.

Lot Area / Lot Width / Lot Depth. The horizontal area within lot lines; the horizontal distance between side lot lines; and the horizontal distance between front and rear lot lines, respectively, measured per this Code.

Lot Coverage. The percentage of lot area covered by buildings and roofed structures (see Building Coverage).

Manufactured Home; Mobile Home. As defined by Texas Occupations Code §1201.003; note that state law distinguishes HUD-code manufactured homes and mobile homes, and binds those definitions on home-rule cities.

Marquee Sign. Shall mean a canopy or covering Structure bearing a signboard or copy projecting from and attached to a Building.

Master Sign Plan. Shall mean a comprehensive document containing specific Standards for an entire Project or property's Signs.

Mixed Use. Development that combines residential with nonresidential uses on the same lot or within the same building.

Modular (Industrialized) Housing / Industrialized Building. As defined by Texas Occupations Code Chapter 1202 (TDLR IHB program)—factory-built modules designed to be installed on permanent foundations (housing) or used as commercial buildings.

Monument Sign. Shall mean a Sign permanently affixed to the ground at its base or by poles that are enclosed by natural stone, stucco, brick, or wood and not mounted to a part of a Building. Pole(s) may be used to construct a Monument Sign so long as the poles are not visible below the Sign.

Mural. A hand painted, hand tiled, printed, or otherwise applied graphic, image, or artwork placed on an exterior surface of a structure or wall and intended to be viewed from the public realm.

Mural Area. The area enclosed within a single continuous perimeter that minimally frames the mural, including any text or symbols within that perimeter. If multiple mural panels are separated by more than 12 inches of blank wall, each panel is measured separately.

Nonconforming Lot / Structure / Use. A lot, structure, or use that was lawfully established but no longer conforms to current requirements of this Code.

No-Impact Home-Based Business. A home-based business that (a) at any time on the property has a combined number of employees and clients/patrons that does not exceed the city's occupancy limit for the property; (b) does not generate on-street parking or a substantial increase in area traffic; (c) conducts no activities visible from a street; and (d) does not substantially increase noise or violate the city's noise rules.

Open Space, Common. Land set aside for parks, recreation, resource protection, or similar purposes, owned and maintained by a homeowners' association, land trust, or public entity.

Parking Space. A permanently surfaced and striped area meeting minimum dimensions for the parking of one vehicle, with safe and convenient access to a public street or aisle, as required by Article 14.04.

Permanent Sign. Any sign securely affixed to the ground, a building, or another structure, designed to remain in place and not easily removed without special handling or tools. These signs are typically made of durable materials like metal, acrylic, or concrete and are intended for long-term use.

Planned Development District (PDD). A site-specific zoning district adopted by ordinance with customized standards and a PD Master Plan, per Article 14.12 and Article 14.02.

Planned Development (PD) Ordinance. The ordinance adopted by the City Council that establishes a Planned Development District (PDD) for a specific property and adopts, by reference, the approved PD Master Plan, Development Standards Matrix, and any exhibits designated as regulatory, together with any conditions of approval and phasing or infrastructure triggers. The PD Ordinance is a legislative zoning action and is not a contract.

Porch. A roofed platform attached to a building, typically at the front façade, which may be open or screened and may encroach per Article 14.02.

Primary Façade. The exterior wall of a building (or the exterior wall area of an individual tenant space) that is intended to be the principal public-facing side of the building, oriented toward and visible from the lot's primary street frontage and generally containing the main public entrance, storefront, or principal customer entry.

Primary Street / Secondary Street. For a given lot, the street designated by the Director as the "primary" for applying frontage and setback/build-to standards (generally the higher-order or addressed street); other abutting streets are "secondary."

Primary Structure. A structure or combination of structures of chief importance or function on a site. In general, the primary use of the site is carried out in a primary structure. The difference between a primary and accessory structure is determined by comparing the size, placement, similarity of design, use of common building materials, and the orientation of the structures on a site.

Primary Use. An activity or combination of activities of chief importance on the site. One of the main purposes for which the land or structures are intended, designed, or ordinarily used. A site may have more than one primary use.

Principal Building / Principal Use. The main building or main use of a lot, as distinguished from accessory buildings or uses.

Public Art Mural. A mural that does not contain a Commercial Message and is not intended to function as a sign.

Pylon Sign. A Sign permanently affixed to the ground at its base by a single- or double-poles, that are enclosed by a base of natural stone, stucco, brick, or wood and not mounted to a part of a Building.

Right-of-Way (ROW). Land dedicated, deeded, or acquired for public streets, utilities, or access, including roadway and sidewalks.

Sidewalk Sign. Shall mean an A-framed, hinged, or folding Sign that is Freestanding and portable and not affixed to a base or pole structure. A Sidewalk Sign can be in the form of a board or an easel.

Sign. Shall mean a structure, Sign, display, light device, figure, painting, drawing, message, plaque, poster, billboard, or other object that is designed, intended, or used that includes text or images designed to communicate. Signs located completely within an enclosed Building and not exposed to view from outside the Building or Structure shall not be considered a Sign. Each display surface of a Sign or Sign Face shall be a Sign.

Sign Administrator. Shall mean the officer appointed by the City Council with the authority to enforce this Code. The Sign Administrator or designee shall review Sign Standards and applications. In the absence of designation by the City Council, the City Administrator shall serve as the Sign Manager. The term also includes any person designated to act on behalf of the Sign Administrator.

Sign Face. Shall mean the total surface including frame and mounting. The actual area of the Sign shall be calculated using trigonometric methods when the Sign is not a simple rectangle. The allowed area of the Sign as stated in the ordinance equals one side of a Freestanding back-to-back Sign provided the Freestanding Sign's sides are back to back or angled with no greater separation between sides at its widest point than 4 feet and provided that both sides have the identical Sign. Frame and mounting shall not exceed 30% of the total surface area of Sign. When referring to area limitations of monument Signs, area and signable area refers to an area within a

continuous perimeter that includes the Sign structure as well as the lettering, illustrations, ornamentations, or other figures, but does not include the Sign base. Required landscaping does not count towards signable area.

Single Family Dwelling (Attached). A building containing one (1) dwelling unit that is attached by a common wall to one or more similar dwelling units, where each unit extends from foundation to roof.

Single Family Dwelling (Detached). A building containing one (1) dwelling unit, designed and intended for residential occupancy, and not attached by a common wall to any other principal building.

Stable (Commercial / Riding Academy). A facility used for the keeping, boarding, training, or rental of horses or other equines, or for providing riding lessons or similar equestrian activities, where such services are offered for compensation to persons other than the owner or occupants of the property. A Commercial Stable or Riding Academy may include barns, paddocks, arenas, riding trails, support buildings, and related facilities, and may be operated as a business or institutional use.

Stable (Private). A facility or area used for the keeping, boarding, or exercising of horses or other equines, and similar large animals, that is incidental and accessory to a residential, agricultural, or institutional use on the same lot and not operated as a business open to the general public. A Private Stable may include barns, paddocks, and riding areas used by the property owner, occupants, and their guests, but does not include riding lessons, horse rental, or boarding services offered for compensation to the general public.

Setback. The required minimum distance between a building or structure and a lot line, measured perpendicular to the lot line.

Shared-Use Path (Sidepath). A paved, generally 8–12-foot-wide path intended for use by both pedestrians and bicyclists, often alongside a roadway or greenway.

Short-Term Rental (STR). Short-term rental (also known as transient rentals, vacation rentals, short-term vacation rentals, or resort dwelling units) means any residential structure, including a single-family home, an accessory dwelling structure, or a unit in an apartment or condominium building, or any portion thereof, used for lodging accommodations to occupants for a period of less than thirty (30) consecutive days. The definition of short-term rental does not include a hotel, motel, bed and breakfast, executive suite, or other non-residential use. Properties rented for longer than 30 days that are still advertised as available on a nightly basis fall into this category.

Sight-Distance Obstruction. Any object between the driver’s eye and a conflict point within the intersection sight triangle that impedes visibility to the minimum distance required by this Code.

Special Flood Hazard Area (SFHA). Land in the floodplain subject to a 1% or greater annual chance of flooding, typically mapped as Zone A and its sub-zones on FEMA FIRMs.

Story. A level of a building between the upper surface of one floor and the upper surface of the floor above (or roof above for the topmost story).

Street. A public or private thoroughfare that affords the principal means of access to abutting property and is constructed to City standards.

Temporary Sign. A sign not intended for permanent display and displayed for a limited period of time, including banners, portable signs, special event signs, and similar signs designed for short term use.

Transparency. The percentage of a building façade area comprised of clear windows and doors, measured as specified by this Code.

Tree, Heritage / Protected. A tree meeting the species, size (caliper/DBH), and condition thresholds established in Article 14.06 (Tree Mitigation) or the Landscape Article.

Urban Farm (Small-Scale Agricultural Operation). A small-scale agricultural operation conducted as the principal use of the property that primarily involves the cultivation of fruits, vegetables, herbs, flowers, and similar crops, where products may be sold or distributed on-site or off-site. An Urban Farm may include accessory structures such as greenhouses, hoop houses, wash/pack areas, and limited accessory sale areas. Urban Farms are generally more intensive and/or larger in scale than Home Gardens or Community Gardens and are intended to be primarily crop-based; any keeping of animals associated with an Urban Farm shall be strictly limited and regulated under the specific use standards of this Code.

Use, Permitted / Conditional / Accessory / Temporary. Categories indicating how and whether a use is allowed in a zoning district, as shown in the Table of Permitted Uses and this Code’s procedures.

Utility Shop / Storage. A building, structure, or secured yard owned or operated by the City or by a franchised/authorized utility provider and used for the storage, staging, dispatch, and maintenance/repair of vehicles, tools, materials, and equipment used to construct, operate, or maintain public utility infrastructure (for

example: water, wastewater, stormwater, electric, gas, or communications). May include accessory administrative offices directly supporting the utility operation. This use does not include:

- 1) **Utility, Minor** (unmanned, in-line, neighborhood-scale distribution facilities such as pump stations, lift stations, small utility boxes, vaults, and similar),
- 2) **Utility, Major** (community-scale production, treatment, storage, or transmission facilities such as treatment plants, major storage, generation, and similar), or
- 3) **Contractor Yards or Shops** not operated by a utility provider (see “Contractor Shop with outdoor yard,” “Outdoor Storage / Equipment,” etc.). Any outdoor storage must comply with outdoor storage, screening, and nuisance performance standards.

Variance. A discretionary relief granted by the Zoning Board of Adjustment for a specific property when strict application of a dimensional standard would create unnecessary hardship, per state law and Article 14.11.

Window Sign. Shall mean Signs that are painted on, etched in, or visible through a window or transparent door of a Building that are oriented in a manner establishing an intent to be viewed off-Premises or from public or private roadways. This term excludes Signs displayed inside of buildings primarily for patrons on the Premises.

Zoning District, Base. A mapped zoning classification applied to land that regulates allowed uses and development standards (e.g., SF, MF, CC, EC), as established in Article 14.02.

ARTICLE 14.15 APPENDICES

Appendix A – Protected Trees, Accepted Native Plants, and Invasive Species List

Use these species for all required tree mitigation under Article 14.06, and appropriate new and replacement tree species unless otherwise approved by the Director/City Arborist. Invasive Species on this list are eligible for credit if removed.

Appendix A: Protected Trees, Accepted Native Plants, and Invasive Species List			
Native Trees	Invasive Trees	Invasive Landscaping Plants & Grasses	Native Landscaping Plants
<ul style="list-style-type: none"> American Elm (<i>Ulmus americana</i>) Bald Cypress (<i>Taxodium distichum</i>) Bigtooth Maple (<i>Acer grandidentatum</i>) Black Jack Oak (<i>Quercus marilandica</i>) Box Elder (<i>Acer negundo</i>) Bur Oak (<i>Quercus macrocarpa</i>) Cedar Elm (<i>Ulmus crassifolia</i>) Chinquapin Oak (<i>Quercus muhlenbergii</i>) Desert Willow (<i>Chilopsis linearis</i>) Eastern Cottonwood (<i>Populus deltoides</i>) Eastern Red Cedar (<i>Juniperus virginiana</i>) Gum Bumelia (<i>Sideroxylon lanuginosum</i>) Hackberry (<i>Celtis laevigata</i>) Live Oak (<i>Quercus virginiana</i>) Loblolly Pine (<i>Pinus taeda</i>) Mexican Buckeye (<i>Ungnadia speciosa</i>) Mexican Plum (<i>Prunus Mexicana</i>) Osage Orange (<i>Maclura pomifera</i>) Pecan (<i>Carya illinoensis</i>) Post Oak (<i>Quercus stellata</i>) Ratama, Paloverde (<i>Parkinsonia aculeate</i>) Red Bud (<i>Cercis canadensis</i> var. <i>texensis</i>) Red Maple (<i>Acer rubrum</i>) Red Mulberry (<i>Morus rubra</i>) Roughleaf Dogwood (<i>Cornus drummondii</i>) Southern Catalpa (<i>Catalpa bignonioides</i>) Sycamore (<i>Platanus occidentalis</i>) Texas Ash (<i>Fraxinus texensis</i>) Texas Hickory (<i>Carya texana</i>) Texas Persimmon (<i>Diospyros texana</i>) Texas Red Oak (<i>Quercus texana</i>) Texas Walnut (<i>Juglans microcarpa</i>) Toothache Tree (<i>Zanthoxylum hirsutum</i>) Western Soapberry (<i>Sapindus saponaria</i> var. <i>drummondii</i>) Wild Cherry <i>Prunus serotina</i> Winged Elm (<i>Ulmus alata</i>) 	<ul style="list-style-type: none"> Ash (all except Texas Ash) (<i>Fraxinus</i> Sp.) Australian Pine <i>Casuarina equisetifolia</i>) Beach Sheoak (<i>Casuarina equisetifolia</i>) Bottlebrush Tree (<i>Melaleuca quinguenervia</i>) Brazilian Pepper Tree (<i>Schinus tевabintifolius</i>) Camphor Tree (<i>Cinnamomum camphora</i>) Carrotwood Tree (<i>Cupaniopsis anacardiodes</i>) China Berry (<i>Melia azedarach</i>) Chinese Elm (<i>Ulmus pumila</i>) Chinese Parasol (<i>Firmiana simplex</i>) Chinese Parasol Tree (<i>Firmiana simplex</i>) Chinese Pistache (<i>Pistacia chinensis</i>) Chinese Tallow (<i>Triadica sebifera</i>) Chinese Wisteria (<i>Wisteria sinensis</i>) Golden Rain Tree (<i>Koelreuteria paniculata</i>) Ligustrum, Privet (<i>Ligustrum lucidum</i>, <i>Ligustrum</i> sp.) Mimosa Tree (<i>Albizia julibrissin</i>) Paper Mulberry (<i>Broussonetia papyrifera</i>) Peepul Tree (<i>Ficus religiosa</i>) Popinac (<i>Leucaena leucocephala</i>) Princess Tree (<i>Paulownia tomentosa</i>) Russian, Autumn Olive (<i>Elaeagnus unbellata</i>) Salt Cedar (<i>Tamarix</i> sp.) Tree of Heaven (<i>Allanthus altissima</i>) True Cedar Tree (<i>Cedrus</i> sp.) Vitex (<i>Vitex agnus-castus</i>) 	<ul style="list-style-type: none"> Japanese Honeysuckle (<i>Lonicera japonica</i>) Nandina (<i>Nandina domestica</i>) Lantana (<i>Lantana camera</i>) Bermuda Grass (<i>Cynodon dactylon</i>) Buffelgrass (<i>Cenchrus ciliaris</i>) Common Reed (<i>Phragmites australis</i>) English Ivy (<i>Hedera helix</i>) Giant Reed (<i>Arundo donax</i>) Bamboo (<i>Phyllostachys</i> sp., <i>Bambusa</i> sp.) Multiflora rose (<i>Rosa multiflora</i>) Rose of Sharon (<i>Hibiscus syriacus</i>) Annual Bluegrass (<i>Poa annua</i>) Carpet Grass (<i>Axonopus</i> sp.) Rye Grass (<i>Lolium</i> Sp) Red Fescue (<i>Festuca rubra</i>) <p style="text-align: center;">Acceptable Non-Native Plants</p> <ul style="list-style-type: none"> Apple (<i>Malus</i> sp.) Crepe Myrtle (<i>Lagerstoemia</i> sp.) Fig (<i>Ficus</i> sp.) Grape (<i>Vitis</i> Sp.) Loquat (<i>Eriobotrya japonica</i>) Peach, Plum (<i>Prunus</i> sp.) Pear (<i>Pyrus</i> sp.) Pomegranate (<i>Punica granatum</i>) Rose (<i>Rosa</i> sp.) Zoysia Grass (<i>Zoysia</i> sp.) 	<ul style="list-style-type: none"> Evergreen Sumac (<i>Rhus virens</i>) Eve's Necklace (<i>Styphnolobium affine</i>) Flameleaf Sumac (<i>Rhus lanceolata</i>) Mountain Laurel (<i>Sophora secundiflora</i>) Possumhaw (<i>Ilex decidua</i>) Red Buckeye (<i>Aesculus pavia</i>) Southern Wax Myrtle (<i>Myrica cerifera</i>) Texas Buckeye (<i>Aesculus glabra</i>) Texas Lantana (<i>Lantana urticoides</i>) Yellow Bells (<i>Tecoma stans</i>) <p style="text-align: center;">Native Landscaping Grasses</p> <ul style="list-style-type: none"> Buffalo Grass (<i>Bouteloua dactyloides</i>) Curly Mesquite (<i>Hilaria berlanderi</i>) Little Bluestem (<i>Schizachyrium scoparium</i>) Inland Sea Oats (<i>Chasmanthium latifolium</i>) SideOats Gramma (<i>Bouteloua curtipendula</i>) Muhly Grasses (<i>Muhlenbergia</i> sp.) Eastern Gamma Grass (<i>Tripsacum dactyloides</i>) Indian Grass (<i>Sorghastrum nutans</i>)

Appendix B – Preferred Plant List

The species listed below shall be used for new plantings on vacant sites and for plantings associated with a Landscape Plan to satisfy landscaping requirements in Article 14.05. These species are the City’s preferred species for urban and constrained environments. Where tree mitigation is required, Appendix A shall govern approved native tree species. Other species may be approved by the City Arborist.

Appendix B: Preferred Plant List			
Canopy (Shade) Trees	Understory/Small Trees	Shrubs	Parking Lot/Constrained Areas
Cedar elm (<i>Ulmus crassifolia</i>)	Texas redbud (<i>Cercis canadensis</i> var. <i>texensis</i>)	Agarita (<i>Mahonia trifoliolata</i>)	<u>Trees:</u> Cedar elm; Desert willow; Yaupon (standard or multi-trunk); Eve’s necklace; Mexican plum; Monterey oak, Live Oak, Bald Cypress (good but may drop fruit)
Winged elm (<i>Ulmus alata</i>)	Mexican redbud (<i>Cercis canadensis</i> var. <i>mexicana</i>)	Dwarf yaupon holly (<i>Ilex vomitoria</i> cvs.)	<u>Shrubs/accents:</u> Cenizo; Damianita; Agarita; Red yucca (<i>Hesperaloe parviflora</i>).
Escarpment live oak (<i>Quercus fusiformis</i>)	Anacacho orchid tree (<i>Bauhinia lunarioides</i>)	Cenizo / Texas sage (<i>Leucophyllum frutescens</i>)	<u>Grasses/groundcovers:</u> Lindheimer or Gulf muhly; Sideoats grama; Frogfruit; Horseherb; Texas sedge.
Monterey/Mexican white oak (<i>Quercus polymorpha</i>)	Mexican plum (<i>Prunus mexicana</i>)	Flame acanthus (<i>Anisacanthus quadrifidus</i> var. <i>wrightii</i>)	Prohibited Species
Chinquapin oak (<i>Quercus muehlenbergii</i>)	Eve’s necklace (<i>Styphnolobium affine</i>)	Rock rose (<i>Pavonia lasiopetala</i>)	Red woods
Bur oak (<i>Quercus macrocarpa</i>)	Texas mountain laurel (<i>Dermatophyllum/Sophora secundiflorum</i>)	American beautyberry (<i>Callicarpa americana</i>)	Chinese tallow (<i>Triadica/Sapium sebiferum</i>)
Lacey oak (<i>Quercus laceyi</i>)	Yaupon holly, tree form (<i>Ilex vomitoria</i>)	Mountain sage (<i>Salvia regla</i>)	Chinese pistache (<i>Pistacia chinensis</i>)
Shumard oak (<i>Quercus shumardii</i>)	Texas persimmon (<i>Diospyros texana</i>)	Damianita (<i>Chrysactinia mexicana</i>)	Privet/ligustrum (multiple species)
Post oak (<i>Quercus stellata</i>)	Desert willow (<i>Chilopsis linearis</i>)	Rusty blackhaw viburnum (<i>Viburnum rufidulum</i>)	Nandina (berrying varieties)
Mexican sycamore (<i>Platanus mexicana</i>)	American Smoketree (<i>Cotinus obovatus</i>)	Evergreen sumac (<i>Rhus virens</i>)	Vitex (<i>Vitex agnus-castus</i>)
Live Oak (<i>Quercus virginiana</i>)		Turk’s cap (<i>Malvaviscus arboreus</i> var. <i>drummondii</i>)	Tree-of-heaven (<i>Ailanthus altissima</i>)
Bald Cypress (<i>Taxodium distichum</i>)			Chinaberry (<i>Melia azedarach</i>)
		Grasses & Groundcovers	English ivy (<i>Hedera helix</i>)
		Lindheimer muhly (<i>Muhlenbergia lindheimeri</i>)	Periwinkle (<i>Vinca major/minor</i>)
		Gulf muhly (<i>Muhlenbergia capillaris</i>)	Running bamboo (<i>Phyllostachys</i> spp.)
		Little bluestem (<i>Schizachyrium scoparium</i>)	Giant reed (<i>Arundo donax</i>)
		Sideoats grama (<i>Bouteloua curtipendula</i>)	Kudzu (<i>Pueraria lobata</i>)
		Blue grama (<i>Bouteloua gracilis</i>)	Chinese parasol tree (<i>Firmiana simplex</i>)
		Inland sea oats (<i>Chasmanthium latifolium</i>)	Bradford/callery pear (<i>Pyrus calleryana</i>)
		Buffalo grass (<i>Bouteloua dactyloides</i>) – low-traffic only	Salt cedar (<i>Tamarix</i> spp.)
		Texas sedge (<i>Carex texensis</i>) and other <i>Carex</i> spp. (e.g., Berkeley/Meadow sedges)	
		Frogfruit (<i>Phyla incisa/nodiflora</i>)	
		Horseherb (<i>Calyptocarpus vialis</i>)	
		Bermuda Grass	
		Lantana	
		Rye Grass	

Appendix C – Site Development Plan Checklist

Adoption and Authority. This “Site Development Plan Submittal Checklist” is adopted by ordinance as Appendix C of the Bastrop Development Code, Chapter 14 of the City of Bastrop Code of Ordinances. The requirements in this Checklist are enforceable as part of Chapter 14 and are intended to supplement, organize, and where applicable mirror the submittal and documentation requirements of Chapter 14. This Checklist establishes the minimum items required for an application to be deemed complete for acceptance and processing, unless waived as not applicable.

Consistency; Controlling Provision. This Checklist shall be applied in a manner consistent with Chapter 14. If any provision of this Checklist conflicts with the text of Chapter 14, the Chapter 14 provision controls.

Applicability; Administrative Use. City staff may use this Checklist to determine application completeness and to identify additional information reasonably necessary to evaluate compliance with Chapter 14 and other applicable City regulations. Items marked “if applicable” are required only when triggered by the proposed development, site conditions, or associated approvals.

City of Bastrop

Site Development Plan (Site Plan) Submittal Checklist - Applicant

Bastrop Development Code (City of Bastrop Code of Ordinances Chapter 14)

Use this checklist to assemble a complete Site Development Plan submittal package.

Project Information

Project Name		Date Submitted	
Site Address		BCAD / Parcel ID	
Zoning District		Overlay(s) (if any)	
Applicant / Company		Phone	
Email		Engineer / Architect (if any)	
Owner Authorization Attached	<input type="checkbox"/> Yes <input type="checkbox"/> No	Pre-Application Completed	<input type="checkbox"/> Yes <input type="checkbox"/> No

General Site Development Plan Submittal Requirements

Provided	Code Section	Required Submittal / Documentation
<input type="checkbox"/>	Sec. 14.13.004 (Site Development Plans)	Completed Site Development Plan Checklist (this checklist).
<input type="checkbox"/>	Sec. 14.13.004 (Site Development Plans)	ALL documents specified on this checklist.
<input type="checkbox"/>	Adopted Checklist Requirement	Agent Authorization Form if Applicant is not the Property Owner.
<input type="checkbox"/>	Adopted Checklist Requirement	Copy of deed showing current ownership.
<input type="checkbox"/>	Adopted Checklist Requirement	A copy of current statement of account showing taxes have been paid.
<input type="checkbox"/>	Sec. 14.13.004 (Fees) and Master Fee Schedule	Required fees.
<input type="checkbox"/>	TxDOT Permit Requirements (Supplemental)	Copy of TxDOT permits when required.

<input type="checkbox"/>	Chapter 16 Stormwater Drainage (Supplemental)	Copy of approved Final Drainage Plan if disturbed area is greater than 5,000 square feet, unless concurrent review is allowed by the City Engineer.
<input type="checkbox"/>	Adopted Checklist Requirement	Copy of a letter outlining Planned Development Requirements and how those requirements are addressed on the Site Development Plan if property is located within a Planned Development District.
<input type="checkbox"/>	Adopted Checklist Requirement	If any required fire code requirements cross into a property other than the owner's, a joint-use access agreement or unified development agreement shall be provided and recorded.
<input type="checkbox"/>	IFC 104.8 and 104.9 (Supplemental)	For projects involving an Alternative Method of Compliance (AMoC), documentation showing the alternate method has been approved per IFC 104.8 and 104.9.

Site Plan Detail Requirements

Provided	Code Section	Required Submittal / Documentation
	#1 (Adopted Checklist Requirements)	COVER SHEET
<input type="checkbox"/>	1.1	Title block (lower right) contains: proposed project name; block designation; lot number; acreage; preparation date and subsequent revisions (revision table).
<input type="checkbox"/>	1.2	Name (company and contact), address, phone number of owner, applicant, and surveyor and/or engineer responsible for the site plan.
<input type="checkbox"/>	1.3	Signature blocks for Owner, City Engineer, Fire Department, and Director of Planning and Development (see Signature Blocks section).
<input type="checkbox"/>	1.4	Fire Department cover sheet table includes:
BASTROP FIRE DEPARTMENT		
Fire Design Codes	International Fire Code 2018 Edition with adopted appendices	
Fire Flow Demand @ 20 psi (gpm)	Most demanding building's calculated fire flow demand – 2018 IFC Appendix B, Table B105.1 – Based on SF and Construction Type	
Intended Use	Most demanding building's intended use	
Construction Classification	Most demanding building's IBC construction classification	
Building Fire Area (S.F.)	Most demanding building's fire area in gross square feet (all floor levels combined) per 2018 IFC Appendix B	
Automatic Fire Sprinkler System Type (if applicable)	The sprinkler system type that is in the most demanding building's fire area – NFPA 13, NFPA 13R or NFPA 13D	
Reduced Fire Flow Demand @ 20 psi for having a sprinkler system (gpm) (if applicable)	Reduced fire flow demand, as permitted by BFS and Appendix B	
Fire Hydrant Flow Test Date	Not more than 1 year from the date of Site Development Plan submittal	
Fire Hydrant Flow Test Location	Block and Street Name	
Alternative Method of Compliance AMOC (if applicable)	AMOC number and the date the AMOC was approved by the City	

<input type="checkbox"/>	1.5	List of ordinances and/or codes used for site design (include Bastrop Development Code Chapter 14 and any other applicable City codes).
<input type="checkbox"/>	1.6	List of jurisdiction and service providers for the site.
<input type="checkbox"/>	1.7	Location map (single line drawing), north arrow, and scale.
<input type="checkbox"/>	1.8	Legend on all plan sheets that use abbreviations or symbols.
	#2 (Adopted Checklist Requirement)	FINAL PLAT
<input type="checkbox"/>	2.1	Copy of Final Plat with recordation info or note that plat is under review. If exempt from platting, provide copy of determination letter, recent survey, and recorded blanket easement.
	#3 (Adopted Checklist Requirements)	OVERALL SITE PLAN SHEET
<input type="checkbox"/>	3.1	Site boundaries, bearings and dimensions, lot lines, and approximate distance to nearest cross street.
<input type="checkbox"/>	3.2	<p>Site Data Summary Chart includes:</p> <ul style="list-style-type: none"> • Zoning district and overlay(s), if any • Lot area excluding ROW (gross and net acreage and square feet) • Percentage of lot coverage (building footprint and impervious areas) • Area of open space (if provided or required by PD/approval) and percent of site • Building area (gross square footage per building) • Building height (feet and stories) • Total parking provided (if off-site, provide location) <ul style="list-style-type: none"> ○ Total ADA parking required ○ Total ADA parking provided ○ Total bicycle parking provided • Loading areas provided (if applicable)
<input type="checkbox"/>	3.3	Entrances and exits to the buildings.
<input type="checkbox"/>	3.4	Existing and proposed building locations, building size/dimensions, finished floor elevation, height, and distances between buildings on the same lot.
<input type="checkbox"/>	3.5	Show building setbacks and any applicable build-to lines, and/or IBC minimum setbacks where relevant.
<input type="checkbox"/>	3.6	Label street type(s) existing and proposed.
<input type="checkbox"/>	3.7	Include public streets, private drives and fire lanes with pavement widths, ROW, median openings, and turn lanes.

<input type="checkbox"/>	3.8	Existing and proposed driveways with dimensions, radii, and surface type.
<input type="checkbox"/>	3.9	Distances (edge to edge) between existing and proposed driveways (on-site and off-site) to next closest street and/or driveway.
<input type="checkbox"/>	3.10	Existing or proposed easements or ROW within or abutting the lot.
<input type="checkbox"/>	3.11	Existing and proposed improvements within 75 feet of subject property; subdivision name; zoning districts adjacent; general use context adjacent.
<input type="checkbox"/>	3.12	Show location of any required open space, common area, dedication area, parkland, drainage reserve, or other required public benefit area when required by PD/approval conditions.
<input type="checkbox"/>	3.13	Dimensions of any street, sidewalk, alley, accessible route, or other part intended to be dedicated to public use. Dedications must be by separate instrument and referenced on the plan.
<input type="checkbox"/>	3.14	On and off-site circulation (including truck loading and pickup areas) and fire lanes.
<input type="checkbox"/>	3.15	Location of ramps, crosswalks, sidewalks, and barrier free ramps with typical dimensions.
<input type="checkbox"/>	3.16	All types of surfacing (asphalt, brick, concrete, sod, crushed granite) not under roof.
<input type="checkbox"/>	3.17: Sec. 14.04.001 (Site Design, Refuse and Recycling Facilities)	Location of dumpster and screening with materials.
<input type="checkbox"/>	3.18	Screening walls, fences, living screens, retaining walls, and service area screens, including height and type of construction and/or planting specifications.
<input type="checkbox"/>	3.19: Sec. 14.04.004 (Off-Street Parking, Loading, Bicycle Parking)	Parking areas and structures including number/layout of spaces, dimensions, drive aisles, loading/unloading areas, ADA spaces, and related details.
<input type="checkbox"/>	3.20: Sec. 14.06.004 (Tree Survey and Removal/Preservation Plan)	Identify heritage and protected trees (and show them on the plan).
<input type="checkbox"/>	3.21	Location and boundary of any regulatory floodplain or floodway (show FEMA data if applicable).
<input type="checkbox"/>	3.22	Proposed dedications and reservations of land for public use including ROW, easements, open space, parkland, drainage ways, floodplains, and facility sites with gross and net acreage.
<input type="checkbox"/>	3.23 (Fire Review)	Limited access control gates across fire lane easements shown and subject to Fire Department approval.

<input type="checkbox"/>	3.24	All improvements located in the ROW.
<input type="checkbox"/>	3.25	Safety barriers, fencing, wheel stops, curbing, or other restrictive barriers adjacent to driveways, aisles, maneuvering, or parking areas.
<input type="checkbox"/>	3.26	Acceptable scale: 1 inch = 40 feet, 1 inch = 100 feet, or similar.
	#4 (Adopted Checklist Requirements)	ENGINEERING REQUIRED DETAILS
<input type="checkbox"/>	4.1	Existing topography at 2-foot contours or less and proposed at 2-foot contours or less.
<input type="checkbox"/>	4.2	Natural features including tree masses and anticipated tree loss, floodplains, drainage ways and creeks.
<input type="checkbox"/>	4.3	FEMA 100-year floodplain with elevation; proposed detention area if required.
<input type="checkbox"/>	4.4	Existing and proposed easements (utility, fire lane, landscape, visibility, access and maintenance, public access, drainage, detention, floodplain drainage easement, etc.).
<input type="checkbox"/>	4.5	Water, sanitary sewer, and franchise utilities mains and service lines with sizes, valves, hydrants, manholes, and other structures on or adjacent to site.
<input type="checkbox"/>	4.6	Water and sewer connections, meter locations, sizes, and meter and/or detector check valve vaults indicated.
<input type="checkbox"/>	4.7	Inlets, culverts, and other drainage structures on-site and immediately adjacent.
	#5 (Adopted Checklist & IFC Requirements)	FIRE ACCESS AND CONTROL PLAN SHEET
<input type="checkbox"/>	5.1	Curb markings and/or signs indicating No Parking - Fire Zone on designated fire lane.
<input type="checkbox"/>	5.2	Location of existing and proposed fire hydrants.
<input type="checkbox"/>	5.3 (IFC 903)	Note if any buildings require an automatic sprinkler system.
<input type="checkbox"/>	5.4 (IFC 901.4.6 and 105.4.2)	Fire sprinkler riser room location labeled, if applicable.
<input type="checkbox"/>	5.5 (IFC 503.1)	Distance between all exterior building walls and required fire apparatus access areas.
<input type="checkbox"/>	5.6 (IFC 503.6)	Motorized gates in fire lane path labeled and provided with Knox key switch, if applicable.
<input type="checkbox"/>	5.7 (IFC 5001.5.1)	Fuel tanks shown with volume, fuel type, and construction standard.
<input type="checkbox"/>	5.8 (IFC 5001.5.2)	Diesel emergency generators shown with UL listing, tank capacity, and impact protection.
	#6 (Adopted Checklist Requirements)	TRAFFIC CONTROL AND PEDESTRIAN SAFETY SHEET

<input type="checkbox"/>	6.1	Temporary Traffic Control Plan for impacted (closed or reduced width) roadways.
<input type="checkbox"/>	6.2	Barricade Summary Table including impacted roadway, classification, intersection, planned improvements, traffic control detail sheet reference, allowed times, and duration.
<input type="checkbox"/>	6.3	Temporary pedestrian route and protection if pedestrian route is impacted.
<input type="checkbox"/>	6.4	Calculations if overhead fall protection is proposed.
<input type="checkbox"/>	6.5	Safety fencing to prevent public access to construction activities.
<input type="checkbox"/>	6.6	Sealed by a Texas Professional Engineer.
	#7 (Adopted Checklist Requirements)	REQUIRED NOTES
<input type="checkbox"/>	7.1	Signs require separate permits; approval of Site Development Plan does not constitute approval of sign plans or elements.
<input type="checkbox"/>	7.2	Underground Main Notes (to be provided on Utility Plan Sheet): A. Underground mains supplying NFPA 13 and 13R systems installed and tested per NFPA 13 and Fire Code by licensed contractor (SCR-U); hydrostatic test requirements as stated. B. Underground mains supplying private hydrants installed and tested per NFPA 24 and Fire Code by licensed contractor (SCR-U); hydrostatic test requirements as stated.
	#8 (Adopted Checklist Requirements)	SUPPLEMENTAL REQUIREMENTS
<input type="checkbox"/>	8.1	Site Development Plan cannot be approved until Final Plat is recorded or Platting Exemption/Lot of Record is issued.
<input type="checkbox"/>	8.2	Site Development Plan must be prepared by a licensed and registered professional land surveyor, licensed professional engineer, or licensed professional architect.
	8.3	Building permits will not be issued until the Site Development Plan is approved.
<input type="checkbox"/>	8.4	Property taxes must be paid prior to approval of plan.
	#9 (Adopted Checklist Requirements)	SIGNATURE BLOCKS
		Signature blocks as approved below shall be placed on the Site Development Plan cover sheet. Signature blocks shall also be placed for any additional entities responsible in preparing the Site Development Plan.
<input type="checkbox"/>	9.1	Surveyor certificate block

<p>The certificate of the licensed public surveyor:</p> <p>THE STATE OF TEXAS § COUNTY OF BASTROP §</p> <p>KNOW ALL MEN BY THESE PRESENTS</p> <p>That I, _____ do hereby certify that I prepare this plat from an actual and accurate on-the-ground survey of the land and that the corner monuments shown thereon were properly placed under my personal supervision, in accordance with the subdivision regulations of the City of Bastrop, Texas.</p> <p>_____ Signature and Seal of Registered Public Surveyor with date.</p>		
<input type="checkbox"/>	9.2	Owner signature block
<p>Owner's Signature Block:</p> <p>As owner of this property, I promise to develop and maintain this property as described by this plan.</p> <p>_____ Name of Owner/Trustee</p> <p>_____ Date</p>		
<input type="checkbox"/>	9.3	City approval signature block (Director, City Engineer, Fire Department).
<p>City Approval Signature Block:</p> <p>All responsibility for the adequacy of these plans remains with the engineer who prepared them. In accepting these plans, the City of Bastrop must rely upon the adequacy of the work of the design engineer.</p> <p>Accepted for Construction:</p> <p>_____ Director of Planning and Development</p> <p>_____ City of Bastrop Engineer</p> <p>_____ City of Bastrop Fire Department</p> <p>_____ Date</p> <p>_____ Date</p> <p>_____ Date</p>		
<input type="checkbox"/>	9.4	Engineer signed and sealed certification block.
<p>Signed and sealed certification of the licensed engineer who prepared the Site Development Plan:</p> <p>I, _____ do hereby certify that the information contained in these engineering documents are complete, accurate, and adequate for the intended purposes, including construction, but are not authorized for construction prior to formal City approval.</p> <p>_____ Signature and Seal of Registered Engineer with date</p>		

	#10 (Adopted Checklist Requirements)	BASTROP FIRE DEPARTMENT GENERAL NOTES
<input type="checkbox"/>	10.1	The Bastrop Fire Department requires final asphalt or concrete pavement on required access roads prior to the start of combustible construction. Any other method of providing "all-weather driving capabilities" shall be required to be documented and approved as an alternate method of construction in accordance with the applicable rules for temporary roads.
<input type="checkbox"/>	10.2	Fire hydrants shall be installed with the center of the large diameter hose connection (steamer) located at least 18 inches above finished grade. The steamer opening of fire hydrants shall face the approved fire access driveway or public-street and set back from the curb line(s) an approved distance, typically three (3) to six (6) feet. The area within three (3) feet in all directions from any fire hydrant shall be free of obstructions and the area between the steamer opening and the street or driveway giving emergency vehicle access shall be free of obstructions.
<input type="checkbox"/>	10.3	Timing of installations: When fire protection facilities are installed by the contractor, such facilities shall include surface access roads. Emergency access roads or drives shall be installed and made serviceable prior to and during the time of construction. When the Fire Department approves an alternate method of protection, this requirement may be modified as documented in the approval of the alternate method.
<input type="checkbox"/>	10.4	All emergency access roadways and fire lanes, including pervious/decorative paving, shall be engineered and installed as required to support the axle loads of emergency vehicles. A load capacity sufficient to meet the requirements for HS-20 loading (16 kips/wheel) and a total vehicle live load of 80,000 pounds is considered compliant with this requirement.
<input type="checkbox"/>	10.5	Fire lanes designated on site plans shall be registered with the Bastrop Fire Department and inspected for final approval.
<input type="checkbox"/>	10.6	The minimum vertical clearance required for emergency vehicle access roads or drives is 13 feet - 6 inches for the full width of the roadway or driveway.
<input type="checkbox"/>	10.7	Dumpsters and containers with an individual capacity of 1.5 cubic yards or more shall not be stored in buildings or placed within ten feet of combustible walls, openings, or combustible roof eave lines.

Bastrop Development Code Specific Requirements

1. Site Development Plan - Minimum Submittal Package

Provided	Code Section	Required Submittal / Documentation
<input type="checkbox"/>	Sec. 14.12.004 (Submittal - Minimum)	Pre-application meeting completed.
<input type="checkbox"/>	Sec. 14.12.004 (Submittal - Minimum)	Site layout sheet showing buildings, setbacks, easements, access, internal circulation, fire lanes, loading, refuse/mechanical, and outdoor activity areas, plus a compliance table.
<input type="checkbox"/>	Sec. 14.12.004 (Submittal - Minimum)	Parking/loading plan showing counts, accessible and bicycle spaces, and parking/loading geometry.
<input type="checkbox"/>	Sec. 14.12.004 (Submittal - Minimum)	Access and Connectivity sheet showing driveway spacing and sight distance, cross-access, sidewalks/trails, and pedestrian routes/ramps.
<input type="checkbox"/>	Sec. 14.12.004 (Submittal - Minimum)	Landscape and irrigation plans sealed by a licensed Landscape Architect.
<input type="checkbox"/>	Sec. 14.12.004 (Submittal - Minimum)	Tree survey performed by an ISA Certified Arborist and accompanying preservation/mitigation plan.
<input type="checkbox"/>	Sec. 14.12.004 (Submittal - Minimum)	Utilities information for domestic, fire, and wastewater, including will-serve/availability as needed.
<input type="checkbox"/>	Sec. 14.12.004 (Submittal - Minimum)	Drainage concept showing ponds/outfalls and a pre/post summary.
<input type="checkbox"/>	Sec. 14.12.004 (Submittal - Minimum)	Lighting/photometric plan where outdoor lighting is proposed or where nighttime operating hours are proposed.
<input type="checkbox"/>	Sec. 14.12.004 (Submittal - Minimum)	Building elevations or massing sufficient to verify height, screening, and transparency.
<input type="checkbox"/>	Sec. 14.12.004 (Submittal - Minimum)	Traffic Impact Analysis (TIA) / traffic study, if required.
<input type="checkbox"/>	Sec. 14.12.004 (Submittal - Minimum)	Phasing plan and timing of frontage/public improvements.
<input type="checkbox"/>	Sec. 14.12.004 (Submittal - Minimum)	Overlay documentation, if applicable.
<input type="checkbox"/>	Sec. 14.12.004 (Submittal - Minimum)	This Site Development Plan checklist completed, including all items required by the checklist.

3. Sheet and Study Content Requirements (Include When Applicable)

This section lists additional documentation that the Code requires to be shown or included within specific plan sheets or studies, or required submittal elements for certain topics (lighting, access and connectivity, landscaping, trees, floodplain, refuse service).

3A. Refuse and Recycling Facilities

Provided	Code Section	Required Submittal / Documentation
<input type="checkbox"/>	Sec. 14.04.001 (Refuse and Recycling Facilities - Applicability)	If nonresidential or multifamily development uses centralized refuse service, include refuse and recycling facilities on the site plan.
<input type="checkbox"/>	Sec. 14.04.001 (Refuse and Recycling Facilities - Location)	Show refuse/recycling facilities located in the side or rear yard (front yard prohibited unless Director determines no feasible alternative due to documented site constraints).
<input type="checkbox"/>	Sec. 14.04.001 (Refuse and Recycling Facilities - Location)	Show that refuse/recycling facilities do not block sidewalks, accessible routes, drive aisles, fire lanes, required parking, or required pedestrian circulation.
<input type="checkbox"/>	Sec. 14.04.001 (Screening and Enclosure Standards)	Provide enclosure details demonstrating full screening by a permanent enclosure; enclosure walls at least 6 ft tall and at least 1 ft above the top of the dumpster/compactor lid; durable materials compatible with the principal building; opaque operable gates; and paved pad with positive drainage.
<input type="checkbox"/>	Sec. 14.04.001 (Truck Access and Maneuvering)	Demonstrate adequate access and maneuvering for collection vehicles. Provide turning templates or other documentation acceptable to the City Engineer when requested.

3B. Sidewalks and Pedestrian Connectivity

Provided	Code Section	Required Submittal / Documentation
<input type="checkbox"/>	Sec. 14.04.002 (When Required)	If sidewalks are required, show sidewalks along all public and private street frontages at the time of the Site Development Plan.
<input type="checkbox"/>	Sec. 14.04.002 (Design, Width, and Placement)	Show sidewalk/path widths consistent with TMP functional class and Code requirements, including ADA-compliant ramps and connections.
<input type="checkbox"/>	Sec. 14.04.002 (Plan Integration)	Demonstrate consistency with the TMP functional class, Thoroughfare Plan, and any adopted Sidewalk/Trails Plans on the site plan.

3C. Outdoor Lighting Documentation

Provided	Code Section	Required Submittal / Documentation
<input type="checkbox"/>	Sec. 14.04.003 (Submittals and Compliance)	Photometric plan sealed by a Texas-licensed Professional Engineer or Registered Architect showing iso-footcandle contours to property lines, point-by-point grid (max/min), fixture locations, and mounting heights.

<input type="checkbox"/>	Sec. 14.04.003 (Submittals and Compliance)	Luminaire schedule with manufacturer cut sheets documenting BUG rating, CCT, lumens, optics, and shielding.
<input type="checkbox"/>	Sec. 14.04.003 (Submittals and Compliance)	Total site lumens calculation against hardscape area.
<input type="checkbox"/>	Sec. 14.04.003 (Submittals and Compliance)	Controls narrative describing curfew dimming and motion sensors for after-hours security (as applicable).
<input type="checkbox"/>	Sec. 14.04.003 (Outdoor Sports and Recreation)	If outdoor sports/recreation lighting is proposed, submit a glare and spill-light control plan.
<input type="checkbox"/>	Sec. 14.04.003 (Lighting) and Adopted Checklist Requirement	Lighting plan showing locations, types, and fixtures for freestanding and wall-mounted lighting.
<input type="checkbox"/>	Sec. 14.04.003 (Lighting) and Adopted Checklist Requirement	Photometric plan extending to property lines.
<input type="checkbox"/>	Sec. 14.04.003 (Lighting) and Adopted Checklist Requirement	Provide total lumens for all fixtures and correlated color temperature (CCT), and demonstrate compliance with BDC lighting standards.

3D. Access and Connectivity Documentation

Provided	Code Section	Required Submittal / Documentation
<input type="checkbox"/>	Sec. 14.04.005 (Submittal Requirements)	Access and Connectivity Plan showing all proposed and future stubs, sidewalks, trails, bicycle facilities, transit elements, and cross-access connections within 200 ft of the site boundaries.
<input type="checkbox"/>	Sec. 14.04.005 (Submittal Requirements)	Draft instruments for any required easements (public access, cross-access, sidewalk/trail) and shared access agreements.
<input type="checkbox"/>	Sec. 14.04.005 (Triggers - TIA)	Provide a Traffic Impact Analysis (TIA) when the project is expected to generate at least 100 new peak-hour trips or at least 1,000 new average daily trips, or when required by the City Engineer or City Council due to safety or operational concerns.
<input type="checkbox"/>	Sec. 14.04.005 (Submittal Requirements)	If applicable, submit the TIA with recommended mitigation, phasing, and cost participation.

3E. Landscaping and Irrigation Documentation

Provided	Code Section	Required Submittal / Documentation
<input type="checkbox"/>	Sec. 14.05.001 (Landscape Plan - Submittals)	Submit a sealed landscape plan prepared by a licensed Landscape Architect with the site plan.
<input type="checkbox"/>	Sec. 14.05.001 (Landscape Plan - Submittals)	Location, size, and species of all trees to be preserved.
<input type="checkbox"/>	Sec. 14.06.004 (Tree Survey and Removal/Preservation Plan)	Tree protection plan.
<input type="checkbox"/>	Sec. 14.05.001 (Landscaping Ordinance)	Location of all plant and landscape material including plants, paving, benches, screens, fountains, statues, berms, ponds (include water depth), and topography.
<input type="checkbox"/>	Sec. 14.05.001 (Landscaping Ordinance)	Species of all plant material.
<input type="checkbox"/>	Sec. 14.05.001 (Landscaping Ordinance)	Size of all plant material.
<input type="checkbox"/>	Adopted Checklist Requirement	All types of surfacing not under roof (asphalt, brick, concrete, sod, crushed granite).
<input type="checkbox"/>	Adopted Checklist Requirement	Spacing of plant material where appropriate.
<input type="checkbox"/>	Sec. 14.05.001 (Landscaping Ordinance)	Layout and description of irrigation/sprinkler/water systems including water source locations.
<input type="checkbox"/>	Sec. 14.05.001 (Landscaping Ordinance)	Description of maintenance provisions.
<input type="checkbox"/>	Adopted Checklist Requirement	Vegetative screening: planted height, mature height, distance between plants.
<input type="checkbox"/>	Adopted Checklist Requirement	Required Note: Irrigation plans require separate permits; approval of Site Development Plan does not constitute approval of irrigation plans/elements.
<input type="checkbox"/>	Sec. 14.05.001 (Landscape Plan - Submittals)	Landscape plan shows calculations of required areas.
<input type="checkbox"/>	Sec. 14.05.001 (Landscape Plan - Submittals)	Landscape plan includes a plant schedule (species, size, quantity).
<input type="checkbox"/>	Sec. 14.05.001 (Landscape Plan - Submittals)	Landscape plan identifies preserved trees.
<input type="checkbox"/>	Sec. 14.05.001 (Landscape Plan - Submittals)	Landscape plan includes an irrigation concept.

<input type="checkbox"/>	Sec. 14.05.001 (Landscape Plan - Submittals)	Landscape plan shows preservation areas and Root Protection Zones.
<input type="checkbox"/>	Sec. 14.05.001 (Landscape Plan - Submittals)	Landscape plan shows LID features and any credits elected under Sec. 14.05.002.
<input type="checkbox"/>	Sec. 14.05.001 (Landscape Plan - Submittals)	Landscape plan shows visibility triangles and utilities.
<input type="checkbox"/>	Sec. 14.05.001 (Landscape Plan - Submittals)	Landscape plan includes maintenance notes.
<input type="checkbox"/>	Sec. 14.05.001 (Cistern Credits)	If electing cistern (rainwater harvesting) credits, delineate the Connected Roof Area with a polygon and label, and include tabulations demonstrating compliance with the cistern-credit table in Sec. 14.05.002.

3F. Tree Survey and Preservation Documentation

Provided	Code Section	Required Submittal / Documentation
<input type="checkbox"/>	Sec. 14.06.004 (Tree Survey)	Submit a tree survey sealed by a Certified Arborist or Landscape Architect.
<input type="checkbox"/>	Sec. 14.06.004 (Tree Survey)	Tree survey includes a vicinity map and property boundaries and acreage.
<input type="checkbox"/>	Sec. 14.06.004 (Tree Survey)	Tree survey shows existing/proposed streets, drainage, and utility easements on or adjacent to the property.
<input type="checkbox"/>	Sec. 14.06.004 (Tree Survey)	Tree survey identifies required preservation and buffer zones.
<input type="checkbox"/>	Sec. 14.06.004 (Tree Survey)	Tree survey lists location, tag number, species, DBH, and condition of each preserved Protected Tree and identifies Heritage/Significant Trees.
<input type="checkbox"/>	Sec. 14.06.004 (Tree Survey)	Tree survey identifies areas proposed for clearing.
<input type="checkbox"/>	Sec. 14.06.004 (Tree Survey)	Tree survey includes recent aerial imagery depicting pre-development conditions.
<input type="checkbox"/>	Sec. 14.06.004 (Tree Survey)	Tree survey includes all trees starting at 8 inches in diameter; include 6-inch trees if seeking credits for preserved trees 6 inches or larger.

<input type="checkbox"/>	Sec. 14.06.004 (Tree Survey)	Tree survey information is not older than two years.
<input type="checkbox"/>	Sec. 14.06.004 (Tree Removal and Preservation Plan)	Submit a Tree Removal and Preservation Plan (drawn to site plan scale) that overlays building footprints, drives, parking, detention, and utilities; delineates CRZ fencing and protection measures; identifies mitigation/replacement/payment-in-lieu; and provides irrigation plans for new plantings where required.

3G. Special Flood Hazard Area (SFHA) Overlay Documentation (If Applicable)

Provided	Code Section	Required Submittal / Documentation
<input type="checkbox"/>	Sec. 14.03.004 (SFHA - Administration)	If the site is within FEMA Zone A/AE or the regulatory floodway, include SFHA documentation in the Site Development Plan submittal.
<input type="checkbox"/>	Sec. 14.03.004 (SFHA - Submittals)	SFHA submittals must include: current FIRM panels; Elevation Certificates; Base Flood Elevations (BFEs); floodway extent; existing/proposed topography; grading/fill limits; drainage paths; and any required hydrologic and hydraulic analyses sealed by a Texas-licensed engineer.
<input type="checkbox"/>	Sec. 14.03.004 (SFHA - Administration)	Where required, submit for a Floodplain Development Permit in addition to zoning, site, and building approvals.

3H. Building Elevations Sheet

Provided	Code Section	Required Submittal / Documentation
<input type="checkbox"/>	Sec. 14.13.004 (Site Development Plans) and Adopted	Dimensioned architectural renderings or elevations of all proposed buildings and structures, including dumpster enclosure.

	Checklist Requirement	
<input type="checkbox"/>	Sec. 14.03.003 (Downtown Historic District) and Adopted Checklist Requirement	If property is in a historic district or designated landmark, Certificate of Appropriateness may be required and exteriors must follow adopted historic standards or adopted design guidelines (as applicable).

Appendix D – Design Guidelines

The Design Guidelines in this Appendix are adopted by the Historic Landmark Commission and the City Council and apply to: (1) all property within the Downtown Historic District; and (2) any individually designated local, state, or nationally designated historic property located within the City of Bastrop.

The Historic Landmark Commission shall review exterior work for consistency with these Design Guidelines and the Secretary of the Interior’s Standards and shall approve, approve with conditions, or deny a Certificate of Appropriateness in accordance with this Code.

These Design Guidelines also include optional guidance for properties within the Downtown Bastrop District, which is the City’s official Main Street Program area, designated by the Texas Historical Commission in 2007.

City of Bastrop Design Guidelines



Adopted XXX

Article 1. Introduction and Purpose

Section 1.01 Title and Purpose

This document shall be known as the “City of Bastrop Design Guidelines for the Downtown Historic District and Downtown Bastrop District” and may be adopted by reference as part of the City’s land development regulations. These Guidelines establish objective and discretionary standards for exterior work, streetscape activity, and new construction within the Downtown districts identified herein.

Section 1.02 Purpose of the Design Guidelines

The purpose of these Guidelines is to protect and enhance the character-defining features of Bastrop’s historic Main Street commercial environment; to support economic vitality through predictable, high-quality design outcomes; to reinforce community identity and placemaking; and to ensure that reinvestment occurs in a manner compatible with the unique history and built form of Downtown.

Section 1.03 Vision for the Downtown and Main Street Districts

The City’s vision is a walkable, active downtown comprised of intact historic commercial buildings and compatible contemporary infill that together create a cohesive streetscape, support local business, encourage reinvestment, and project a distinctly Bastrop identity. The Downtown Historic District shall remain the most historically authentic and visually consistent part of downtown, while the Downtown Bastrop District shall accommodate a wider range of architectural expression, including contemporary Texas Hill Country and vernacular-influenced design, provided that the resulting streetscapes remain pedestrian-oriented, human-scale, and durable.



Figure 1-1 Historic Downtown (Main Street) Streetscape



Figure 1-2 Chestnut Street Corridor Vision



Paul Luce Photography

Section 1.04 Relationship to Zoning, Building Codes, and Preservation Requirements

These Guidelines are intended to be used in conjunction with adopted zoning standards, building and fire codes, sign regulations, floodplain requirements where applicable, and accessibility standards. Where conflicts occur, the most restrictive applicable standard shall govern. For any structure located within the Downtown Historic District, and for any individually designated historic structure located outside the Downtown Historic District but within the City, exterior work shall be reviewed for consistency with the Secretary of the Interior's Standards for Rehabilitation, in addition to these Guidelines.

Section 1.05 How to use this Document

Property owners and tenants should use these Guidelines to plan maintenance, improvements, signage, and outdoor activity in a manner consistent with Downtown character. Developers and design professionals should use these Guidelines to shape building form, materials, transparency, and streetscape interface early in design. City staff shall apply these Guidelines during administrative review and in preparing findings and recommendations for boards and commissions. Boards and commissions shall use these Guidelines to evaluate Certificates of Appropriateness and design-related approvals, with particular emphasis on the Secretary of the Interior's Standards for any project subject to those Standards.

Section 1.06 Graphic and Mapping Placeholders

Figures referenced in this document are intended to be inserted at adoption. Figure references may be satisfied with City-prepared maps, diagrams, and illustrative examples approved for use with these Guidelines.



Article 2. Applicability and Boundaries

Section 2.01 Districts Established and Relationship

Two Downtown districts are addressed in these Guidelines. The “Downtown Historic District” is the City’s official National Register historic district on historic Main Street in downtown Bastrop and is a smaller district located within the broader Downtown Bastrop District. The Downtown Historic District is comprised of historic (contributing and noncontributing) commercial buildings and is subject to the highest level of preservation and compatibility expectations. The “Downtown Bastrop District” is the City’s official Texas Main Street Program area certified by the Texas Historical Commission and functions as a larger downtown area that includes both historic and non-historic properties. The Downtown Historic District is a subset of the Downtown Bastrop District. Where a property is within both boundaries, the Downtown Historic District standards and review lens shall control.

Section 2.02 Official Maps and Boundaries

The boundaries of the Downtown Historic District and the Downtown Bastrop District shall be as shown on the official map adopted by the City and maintained by the Development Services Department. Where a question arises regarding boundary interpretation, the City shall rely on the adopted map and supporting records, including plats, surveys, and GIS layers maintained by the City.



Figure 2-1 Downtown Historic District



Figure 2-2 Downtown Bastrop District

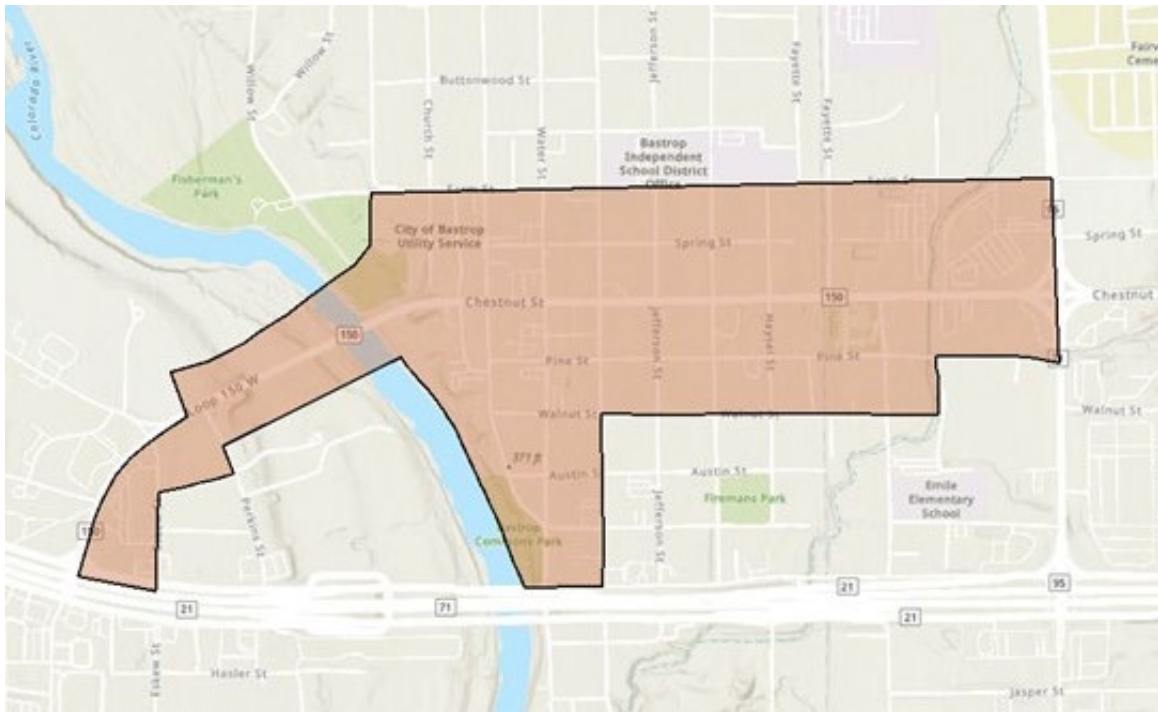

Section 2.03 Covered Properties and Projects

These Guidelines apply to exterior work visible from the public right-of-way and to site features and streetscape activity that affect pedestrian experience within the Downtown Historic District and Downtown Bastrop District. Covered work includes, but is not limited to, façade alterations; storefront modifications; window and door replacement; exterior material changes; roof and parapet work visible from the street; new signage; awnings and canopies; exterior lighting; outdoor dining and sidewalk encroachments; screening of service functions; and new construction, additions, and demolition.

In addition to the geographic districts described in this document, these Guidelines also apply to any property or structure within the corporate limits of the City of Bastrop that is designated as a historic resource at the local, state, or national level, regardless of whether the property is located within the Downtown Historic District or the Downtown Bastrop District. Such designated properties and structures are subject to design review consistent with the Secretary of the Interior's Standards for Rehabilitation and any applicable provisions of the Downtown Historic District guidelines as determined by the Historic Landmark Commission.

Section 2.04 Secretary of the Interior Standards and Applicability of Downtown Historic District Provisions

For any structure located within the Downtown Historic District, and for any locally, state, or nationally designated property or structure within the City of Bastrop, exterior work shall be reviewed for consistency with the Secretary of the Interior's Standards for Rehabilitation. In conducting such review, the Historic Landmark Commission may apply relevant standards from the Downtown Historic District sections of these Guidelines where those standards are determined to be applicable to the designated resource, even when the resource is located outside the Downtown Historic District boundaries. The Historic Landmark Commission's determination regarding applicability of Downtown Historic District provisions to a designated resource shall control, subject to any appeal rights established by ordinance.

Where these Guidelines address the same subject matter as other adopted City requirements, the most restrictive applicable requirement shall govern.

Section 2.05 Review Authority and Required Design Approvals

Within the Downtown Historic District, and for any locally, state, or nationally designated historic property or structure within the City of Bastrop, the Historic Landmark Commission shall be the



design review authority. Such properties and projects shall require review using the Secretary of the Interior's Standards for Rehabilitation and these Guidelines, and shall require a Certificate of Appropriateness in accordance with the City's Historic Preservation Ordinance and adopted procedures.

For properties located within the Downtown Bastrop District that are not otherwise designated as historic resources and are not located within the Downtown Historic District, design review is recommended by the Main Street Advisory Board. Such projects are recommended to comply with the guidelines of the Downtown Bastrop District standards. The Main Street Advisory Board and Main Street staff may provide additional nonbinding façade and design guidance upon request.

Section 2.06 Administrative Approvals and Minor Work

Routine maintenance (as defined in the Historic Preservation Ordinance) and minor work may be handled administratively when the work does not alter historic character and is consistent with these Guidelines, in accordance with the City's adopted procedures within the Historic Preservation Ordinance. Emergency repairs necessary to address an immediate safety hazard may be authorized administratively, provided that permanent repairs and any resulting exterior changes remain consistent with these Guidelines and, where applicable, the Secretary of the Interior's Standards and Certificate of Appropriateness requirements.

Section 2.07 Relationship to Permits and Other City Requirements

Nothing in these Guidelines eliminates the requirement to obtain all other permits and approvals required by the City, including building permits, sign permits, and any approvals required under the City's Historic Preservation Ordinance. The Certificate of Appropriateness described herein are design determinations and shall be obtained as required prior to issuance of permits where applicable under City ordinance and procedure.



Article 3 Guiding Principles

Section 3.01 Preservation of Authentic Historic Character

The City shall prioritize preservation of authentic historic character in the Downtown Historic District by retaining historic form, materials, workmanship, and character-defining features. Rehabilitation shall favor repair over replacement and shall avoid treatments that remove historic fabric or create a false historical appearance.

Section 3.02 Compatible, Human Scale Development

New development and alterations should reinforce the human-scale character of downtown by maintaining active ground floors, appropriate transparency, façade rhythm consistent with historic parcel patterns, and a strong pedestrian orientation.

Section 3.03 Reinvestment and Place Identity

The City encourages reinvestment in downtown buildings and sites when it strengthens place identity, supports local business, and improves long-term building performance without eroding character and authenticity.

Section 3.04 Discouragement of Demolition of Contributing Structures

Demolition of contributing historic structures in the Downtown Historic District is strongly discouraged. When demolition is proposed, the applicant bears the burden of demonstrating compliance with applicable preservation ordinances and demonstrating that alternatives have been reasonably evaluated.

Section 3.05 Pedestrian Oriented Streetscapes

Downtown streetscapes shall maintain continuous walkability, legibility, and comfort. Building entries, storefront visibility, shade, lighting, and sidewalk management shall support a safe and accessible pedestrian environment.



Figure 3-1 Downtown Historic District Streetscape



Section 3.06 Craftsmanship, Quality Materials, and Durability

The City favors authentic, durable materials and details. Brick, limestone, wood, metal, and high-quality fiber cement are generally appropriate when properly detailed. Thin veneers, low-durability synthetic systems, and prototype suburban façade treatments are discouraged in both districts, and particularly discouraged at the ground floor. Material authenticity includes avoiding “fake” masonry appearances and ensuring required masonry percentages are met with true brick and limestone, not substitute or simulated systems.

Article 4 Historic Building Context

Section 4.01 Overview of Historic Building Types

The Downtown Historic District is characterized by traditional commercial buildings, typically one to two stories, aligned at or near the sidewalk, with flat or concealed roofs behind parapets, repetitive storefront bays, large ground-floor display windows, transoms, recessed entries where historically present, and upper-story windows organized in a regular rhythm.

Section 4.02 Character-Defining Features

Character-defining features include storefront systems, transom windows, bulkheads, cornices, parapets and coping, masonry patterns and details, historic window openings and proportions, original door locations, and historic sign bands. Preservation of these features is fundamental to maintaining historic character.

Figure 4-1 Original Cornice on Historic Masonry Building



Section 4.03 Typical Facade Elements and Materials

Common façade elements include masonry walls with brick and stone detailing, wood or metal storefront framing, traditional awnings, and historically scaled signage. Materials commonly found in the district include brick, limestone and other stone, wood, and metal. The historic streetscape depends on the visual continuity of these materials and the proportional relationships among openings, piers, and parapet lines.

Section 4.04 What Preservation Means in Practice

Preservation, as applied by these Guidelines, means retaining historic materials where feasible; repairing rather than replacing; replacing in kind when required; ensuring new work does not damage or obscure historic features; and designing any addition or new construction to be clearly of its time while compatible with the established historic context.

Article 5 Treatment of Existing Buildings

Section 5.01 Applicability of this Article

This Article applies to existing buildings in both districts. Within the Downtown Historic District, this Article shall be applied in a manner consistent with the Secretary of the Interior's Standards for Rehabilitation, with priority placed on retention of historic fabric and character-defining features. Existing buildings that are not within the Bastrop Historic District and not otherwise historically designated may not be required to retain all original features if the building is less than 50 years or as determined by the Main Street Advisory Board.

Section 5.02 Storefronts

Original storefront features shall be retained and repaired when feasible. Historic storefront configurations should be restored when evidence supports restoration, including reopening of historically transparent display areas, restoration of transoms, and reinstatement of recessed entries where historically present. Modern alterations that conceal or flatten storefront depth, cover historic details, or materially reduce transparency are discouraged. In the Downtown Historic District, bricking in or otherwise infilling display windows, substantially reducing storefront openings, or replacing commercial storefront proportions with residential-style punched openings is inconsistent with the intended historic commercial character.

Ground-floor transparency shall be maintained as a defining storefront characteristic. In the Downtown Historic District, the primary street-facing façade shall provide a minimum of seventy percent (70%) ground-floor transparency. In the Downtown Bastrop District, the primary street-facing façade shall provide a minimum of fifty percent (50%) ground-floor transparency.

Transparency shall be calculated on the ground-floor plane between two feet and ten feet above the finished sidewalk grade. Clear glazing in doors and display windows may be counted. Opaque, mirrored, or highly reflective glazing shall not be used to satisfy the transparency requirement.

For corner buildings and any building with more than one street-facing façade, these ground-floor transparency requirements apply to each street-facing façade, including the secondary frontage.



Figure 5-1 Ground Floor Transparency



Section 5.03 Windows and Doors

Original window and door openings shall be maintained. Repair is preferred over replacement. Where replacement is necessary, replacements shall match the original opening size, proportions, and visual depth to the greatest extent feasible. In the Downtown Historic District, replacement windows and doors shall be selected and detailed to maintain historic character, including appropriate frame profiles, muntin patterns where applicable, and recess depth. New openings on primary façades in the Downtown Historic District are generally inappropriate unless supported by historic documentation and demonstrated to be consistent with the Secretary of the Interior’s Standards.

Section 5.04 Masonry and Exterior Materials

Historic masonry shall be preserved and maintained using methods that avoid damage. Cleaning shall use the gentlest means possible. Abrasive cleaning methods that damage masonry surfaces are not appropriate. Repointing shall use mortar compatible in hardness, composition, color, and tooling with historic masonry to avoid long-term damage.

Street-facing façades within both districts should maintain a durable material presence consistent with downtown character. At least twenty-five percent of each street-facing façade shall be comprised of brick or limestone, with locally sourced materials preferred where feasible.

For purposes of meeting this masonry minimum, fake or synthetic stucco systems (including EIFS and similar systems), split-face block, concrete block, cinder block, and other concrete masonry unit products shall not be counted toward the required brick or limestone percentage. For corner buildings and any building with more than one street-facing façade, the masonry requirement applies to each street-facing façade, including the secondary frontage.

Painting previously unpainted historic brick or stone is strongly discouraged and, within the Downtown Historic District, shall require a Certificate of Appropriateness when proposed. Where masonry has historically been painted or where prior coatings have already altered the surface, color changes shall be reviewed for compatibility and for long-term maintenance implications, and must obtain a Certificate of Occupancy. Coatings that trap moisture or accelerate masonry deterioration are not appropriate.

Color and exterior material selections for historic resources shall be guided by the building's documented period of significance (including historically appropriate palettes, materials, and finishes for that period). Where multiple stories are present, exterior cladding changes on street-facing façades should be applied in a consistent manner across all levels to avoid "material downgrades" on upper stories and to maintain a cohesive façade composition.

Section 5.05 Roofs, Parapets, and Mechanical Equipment

Original rooflines and parapets shall be maintained. Historic parapet shapes, cornices, coping, and related details shall be preserved and repaired when feasible. New rooftop elements visible from the public right-of-way, including mechanical equipment, shall be screened in a manner compatible with the building and streetscape. Screening shall be integrated into the building design and shall not introduce visually dominant massing that competes with historic parapet lines.

Section 5.06 Additions and Rear and Side Expansions

Additions should follow a placement hierarchy that prioritizes rear additions first, side additions second, and avoids front additions that alter the primary façade or street wall. Additions shall be subordinate to the original building in massing and shall be designed so that the historic building remains legible. In the Downtown Historic District, additions shall be differentiated from the historic



building while remaining compatible in overall scale, materials, and proportions, consistent with the Secretary of the Interior's Standards.



Article 6 Design Guidelines for New Construction

Section 6.01 Intent and District Application

New construction shall reinforce downtown form, support pedestrian activity, and respect established patterns of massing and façade rhythm. In the Downtown Historic District, new construction shall be compatible with the historic commercial context without creating false historicism. In the Downtown Bastrop District, new construction may express a contemporary Texas Hill Country or vernacular influence, provided it maintains downtown urban form and meets the transparency and materials requirements herein.

Section 6.02 Site Orientation and Setbacks

New buildings shall orient primary entrances to the street and shall maintain a street-facing frontage consistent with downtown patterns. Setbacks should align with established block conditions, with building faces located at or near the sidewalk where historic storefront patterns exist and along commercial corridors. Corner sites shall address both street frontages with active design elements, and primary entrances should reinforce corner prominence where feasible. For corner buildings and any building with more than one street-facing façade, the secondary frontage shall be designed to meet the same façade requirements as the primary frontage, including transparency, material standards, and façade articulation.

Section 6.03 Height, Scale, and Massing

New buildings shall be compatible with adjacent contributing historic buildings and shall not overwhelm historic structures through excessive height at the street wall, unbroken massing, or disproportionate façade scale. Where additional height is proposed adjacent to smaller-scale buildings, upper stories should be set back and massing should be articulated to preserve a comfortable street-level scale.

Within the Downtown Historic District, the prevailing historic scale should remain the dominant reading from the sidewalk. In the Downtown Bastrop District, additional flexibility may be accommodated when transitions are carefully managed through step-backs, façade articulation, and material hierarchy.



Along a single block face, rooftops, parapet heights, and roofline expressions should vary from building to building to reflect traditional incremental development patterns; long, uninterrupted rooflines or identical repeated roof forms across multiple façades on the same block are discouraged.

Section 6.04 Materials and Architectural Character

Within the Downtown Bastrop District, the street-facing façades should include a minimum of twenty-five percent brick or limestone, with locally sourced materials preferred where feasible. Materials shall be durable and appropriately detailed for a prominent downtown context. Architectural metal panels and similar contemporary cladding systems may be permitted, particularly in the Downtown Bastrop District, but metal siding or metal panel cladding should not exceed fifty percent of any street-facing façade. Within the Downtown Historic District, contemporary materials may be used when clearly subordinate to the primary masonry and storefront character and when detailed to avoid a suburban or temporary appearance.

For purposes of meeting the required brick or limestone minimum, fake or synthetic stucco systems (including EIFS and similar systems), split-face block, concrete block, cinder block, and other concrete masonry unit products shall not be counted toward the required brick or limestone percentage. Street-facing façades should use consistent and uniform primary exterior materials across all stories and levels of the façade, with material changes limited to appropriate trim, storefront framing, sign bands, cornices, and similar architectural elements rather than a shift to lower-quality materials on upper levels.

Interpretation of historic character is encouraged; mimicry that results in false historicism is discouraged. Compatibility should be achieved through massing, rhythm, proportions, storefront organization, and material authenticity, rather than through applied imitation ornament.

Section 6.05 Façade Rhythm, Proportions, and Transparency

Façade rhythm should respect established downtown patterns, including vertical bay spacing, consistent window alignment, and a clear storefront base that supports pedestrian activity. Long façades shall be broken into bays that reflect historic parcel rhythm through pilasters, piers, changes in plane, or material transitions that read as structural.

Ground-floor transparency is mandatory to ensure an active streetscape. In the Downtown Historic District, a minimum of seventy percent ground-floor transparency is required on the primary street-



facing façade. In the Downtown Bastrop District, a minimum of fifty percent ground-floor transparency is recommended on the primary street-facing façade. Transparency shall be measured between two feet and ten feet above finished sidewalk grade and shall be comprised primarily of clear glazing intended for display and visibility. For corner buildings and any building with more than one street-facing façade, the transparency requirements apply to each street-facing façade, including the secondary frontage.

Figure 5-1 Ground Floor Transparency



Article 7 Signs, Awnings, and Lighting

Section 7.01 Sign Types and General Intent

Signs shall be pedestrian-scaled, compatible with downtown architecture, and designed to reinforce storefront visibility without overwhelming façades. Historic sign restoration is encouraged when supported by documentation and executed with appropriate materials and workmanship.

Section 7.02 General Sign Standards

Signs should be located in traditional sign areas, including sign bands, storefront glazing, and modest projecting signs (blade signs). Materials should be durable and appropriate to downtown character. Illumination should favor external downlighting or halo lighting. Internally illuminated box signs are discouraged and may be prohibited on primary pedestrian streets when inconsistent with downtown character.

Section 7.03 Awnings and Canopies

Awnings and canopies should provide shade, enhance pedestrian comfort, and reinforce storefront rhythm. Fabric awnings and appropriately detailed metal canopies are generally appropriate. Awnings should be located and sized to avoid obscuring character-defining features. Backlit plastic awnings are discouraged.

Figure 7-1 Awnings and Canopies



Section 7.04 Lighting

Exterior lighting shall be warm, pedestrian-friendly, and designed to limit glare and spillover. Fixtures should be shielded where appropriate and scaled for downtown use. Building-mounted lighting should complement architectural features without creating harsh illumination or visual clutter. All exterior lighting, including building-mounted fixtures, site lighting, and sign illumination, shall comply with the City's Dark Sky Ordinance, including applicable requirements for shielding, light trespass, and permitted light levels.

Article 8 Site and Streetscape Elements

Section 8.01 Sidewalks, Paving, and Pedestrian Clear Path

Sidewalks are a defining downtown asset and shall remain safe, accessible, and unobstructed. Streetscape design and sidewalk use shall maintain a continuous accessible route consistent with applicable accessibility requirements. The City's operational standard for downtown sidewalk management should maintain a clear pedestrian through-zone that is preferably six feet wide and, where constrained conditions exist, not less than four feet wide, with passing opportunities and transitions managed to preserve accessibility and comfort.

Section 8.02 Outdoor Dining and Sidewalk Activation

Outdoor dining and sidewalk activity may be permitted when it supports downtown vitality while protecting accessibility and pedestrian flow. Furniture, menu boards, planters, and similar items shall be organized within a designated activation zone so the pedestrian through-zone remains clear and continuous. Encroachments shall not obstruct entrances, curb ramps, crosswalk approaches, or required clearances. The City may require a sidewalk café or encroachment permit that documents the layout, clear path dimensions, hours of operation, and removable nature of furnishings.

Section 8.03 Street Trees, Planters, and Landscaping

Street trees and landscaping should enhance shade and comfort while preserving visibility into storefronts and maintaining clear pedestrian routes. Plant materials and planters should be durable and should not create pinch points within the pedestrian through-zone. Landscape elements should be coordinated with utilities, drainage, and sight distance requirements.

Section 8.04 Fences, Screening, and Service Areas

Service areas, dumpsters, loading zones, and outdoor storage shall be screened from primary pedestrian streets. Screening shall be durable, appropriately scaled, and compatible with building materials. Blank screening walls without articulation are discouraged where visible from public areas.

Chain-link fencing is prohibited within any front yard and along street-facing frontages. Front-yard fences may be permitted up to a maximum height of fifty-four inches (54 in.), provided the fence



maintains at least fifty percent (50%) transparency (open area), and is constructed of durable, visually compatible materials (for example, metal picket or similar open-style fencing).

Section 8.05 Mechanical Equipment and Utilities at Grade

Ground-mounted mechanical equipment and utilities visible from the public right-of-way shall be screened or integrated into building and site design. Screening shall avoid creating visual clutter and shall not impair pedestrian circulation.



Article 9 Parking and Access

Section 9.01 Parking Location and Hierarchy

Parking should be located to the rear of buildings whenever feasible to preserve downtown street walls and storefront continuity. Front-lot parking along primary downtown streets is discouraged where it interrupts the pedestrian environment and historic development pattern.

Section 9.02 Shared Parking and District Solutions

Shared parking arrangements are encouraged to reduce redundant paved areas and support efficient downtown land use. Applicants should demonstrate how parking demand will be met through shared lots, on-street parking, structured parking where available, and operational strategies that support downtown walkability.

Section 9.03 Driveways, Curb Cuts, and Alley Access

New curb cuts on primary downtown streets are discouraged. Access should prioritize alleys and shared driveways where feasible. Where new access is unavoidable, it shall be designed to minimize conflicts with pedestrians, preserve street trees where feasible, and reduce the visual disruption of the street wall.



Article 10 Sustainability and Resiliency

Section 10.01 Adaptive Reuse

Adaptive reuse is encouraged as a primary downtown sustainability strategy. Reuse extends building life, reduces demolition waste, and supports economic reinvestment while preserving community identity.

Section 10.02 Energy Efficiency Improvements Compatibility with Historic Character

Energy upgrades are encouraged when they do not materially alter historic character. Improvements should prioritize measures that preserve façade integrity, maintain historic window openings, and avoid inappropriate exterior alterations. Rooftop equipment and solar installations should be located and screened to reduce visibility from the public right-of-way, particularly in the Downtown Historic District.

Section 10.03 Stormwater and Durable Materials

Projects should incorporate durable materials and stormwater strategies appropriate to downtown conditions. Where stormwater features are visible, they should be integrated into streetscape design in a manner consistent with pedestrian circulation and downtown aesthetics.

Section 10.04 Dark-Sky-Friendly Lighting

Lighting should minimize glare, uplight, and spillover. Warm color temperatures and shielded fixtures are encouraged to support a comfortable downtown night environment. All exterior lighting shall comply with the City's Dark Sky Ordinance, including applicable limits on light levels and light trespass.



Article 11 Administrative Process

Section 11.01 Purpose and Scope of Administrative Process

This Article establishes the review authorities, approval types, submittal requirements, and enforcement framework for projects subject to these Guidelines. The process is intended to provide predictable pathways for routine work, ensure appropriate public review for work affecting historic resources, and implement the distinct review roles of the Historic Landmark Commission and the Main Street Advisory Board.

Section 11.02 Review Authority and Jurisdiction

The Historic Landmark Commission shall be the design review authority for all exterior work subject to the City's Historic Preservation Ordinance within the Downtown Historic District. The Historic Landmark Commission shall also be the design review authority for any locally, state, or nationally designated property or structure located anywhere within the corporate limits of the City of Bastrop, even when such designated property or structure is located outside the Downtown Historic District and outside the Downtown Bastrop District.

In conducting review of designated historic resources, the Historic Landmark Commission shall apply the Secretary of the Interior's Standards for Rehabilitation and may apply any applicable provisions of the Downtown Historic District sections of these Guidelines, as determined appropriate by the Historic Landmark Commission based on the resource type, historic character, and proposed scope of work.

The Main Street Advisory Board shall be the design review recommending body for properties located within the Downtown Bastrop District that are not otherwise locally, state, or nationally designated and are not located within the Downtown Historic District. For such properties, the Main Street Advisory Board is available upon request for additional facade and design guidance, and may provide recommendations based on these guidelines.

Section 11.03 Required Approvals and Certificates

Projects located within the Downtown Historic District, and projects affecting any locally, state, or nationally designated property or structure within the City of Bastrop, shall require a Certificate of Appropriateness when required by, and in the manner outlined in, the City's Historic Preservation Ordinance and adopted procedures. Such projects shall be reviewed by the Historic Landmark Commission.

No additional permits or Certificates are required for properties located within the Downtown Bastrop District, but may seek design advice from the Main Street Advisory Board or Main Street staff upon request.

Nothing in these Guidelines alters the requirement to obtain all other permits and approvals required by the City. Certificates issued under this Article are design determinations and shall be obtained prior to issuance of permits where required by City ordinance and procedure.

Section 11.04 Administrative Approvals versus Commission or Board Approvals

Routine maintenance and minor work that does not alter character-defining features, does not reduce required transparency, and does not change exterior materials or openings may be approved administratively when authorized by the City's adopted procedures. Administrative approvals are intended to streamline predictable, low-impact work while maintaining consistency with these Guidelines.

Work that materially affects a building's exterior appearance, historic character, storefront configuration, fenestration, exterior materials, rooflines visible from the public right-of-way, signage type or illumination, or sidewalk encroachments beyond routine removable furnishings shall be referred to the appropriate review body based on jurisdiction under Sec. 11.02.

Emergency repairs necessary to address an immediate safety hazard may be authorized administratively. Where emergency work affects a designated historic resource or a property within the Downtown Historic District, the applicant shall return for Historic Landmark Commission review and obtain a Certificate of Appropriateness for permanent repairs when required by the Historic Preservation Ordinance.

Section 11.05 When a Certificate of Appropriateness is Required

A Certificate of Appropriateness shall be required for exterior work within the Downtown Historic District and for exterior work on any locally, state, or nationally designated property or structure within the City of Bastrop when such work is regulated by the City's Historic Preservation Ordinance. Determinations regarding whether a proposed action requires a Certificate of Appropriateness shall be made in accordance with the Historic Preservation Ordinance and adopted procedures. The Historic Landmark Commission's review shall include findings addressing consistency with the Secretary of the Interior's Standards for Rehabilitation and applicable provisions of these Guidelines.



Section 11.07 Submittal Requirements

Applicants shall submit sufficient information to allow an objective evaluation of compliance with these Guidelines and, where applicable, the Secretary of the Interior's Standards. Submittals shall generally include current photographs of all affected elevations and the broader streetscape context; dimensioned elevations when altering openings, materials, or storefront configuration; a materials and finish schedule; a color schedule; product cut sheets for windows, doors, lighting, awnings, and signs as applicable; site plans for any outdoor dining or encroachments; and a ground-floor transparency calculation for affected street-facing façades.

For projects within the Downtown Historic District and for any locally, state, or nationally designated property or structure, submittals shall also include a brief narrative describing how the proposed work meets the Secretary of the Interior's Standards for Rehabilitation and how the project retains and protects character-defining features.

Section 11.08 Appeals

Appeals of administrative determinations, decisions of the Historic Landmark Commission shall be processed in accordance with the City's adopted appeal procedures and the City's Historic Preservation Ordinance, as applicable.

Section 11.09 Enforcement

Violations of these Guidelines, including work performed without the required Certificate of Appropriateness, and unauthorized sidewalk encroachments or exterior alterations, shall be subject to enforcement pursuant to City ordinance. The City may require corrective action, restoration, removal of noncompliant work, or other remedies as authorized by ordinance.

Section 11.10 Relationship to Permits and Occupancy

Approval under this Article does not constitute a building permit, sign permit, or authorization to commence work. Where required by ordinance or procedure, applicants shall obtain the applicable Certificate of Appropriateness prior to permit issuance. Issuance of permits and authorization for occupancy remain subject to compliance with all applicable City codes and standards.



Article 12 Appendices

Section 12.01 Appendix A: Glossary of Terms

The following terms are provided to support consistent application of these Guidelines. Where a term is defined in the City's Development Code or Historic Preservation Ordinance, the City definition shall control.

Addition. New construction that increases the exterior envelope of an existing building, including rear, side, or vertical expansions.

Arcade. A covered pedestrian passage at the building frontage supported by columns or piers.

Awning. A roof-like cover, typically fabric or metal, projecting from a building and designed to provide shade or weather protection.

Bay. A vertical division of a façade, typically defined by structural piers or columns and the spacing of openings, creating a repeating rhythm.

Bulkhead. The solid panel area at the base of a storefront display window, typically below the glazing and above the sidewalk or finished floor.

Canopy. A rigid, permanent roof-like projection over an entry or sidewalk area, usually metal or other durable material.

Character-defining feature. An architectural element or material that contributes to a building's historic identity, such as a storefront system, parapet, cornice, original masonry detailing, or original fenestration pattern.

Cladding. An exterior finish material applied to a building envelope, including masonry, wood, metal panels, fiber cement, and other siding systems.

Cornice. The projecting horizontal element at the top of a wall or parapet, often decorative, that caps the façade.

Coping. The protective cap on top of a parapet wall, often stone, metal, or masonry, designed to shed water.

Display window. A large ground-floor window designed for visibility into retail space and merchandise display.

Façade. The exterior face of a building, typically the principal street-facing elevation.



Fenestration. The arrangement, size, proportion, and pattern of windows and doors on a façade.

Frieze/Sign band. The horizontal area above a storefront, traditionally used for signage and typically aligned with the storefront system.

Glazing. The glass component of windows and doors.

Head. The top horizontal element of a window or door opening.

Historic fabric. Original or historic-era materials and construction components of a building, including masonry, windows, doors, trim, and structural elements.

In-kind repair. Repair or replacement using the same or substantially similar materials, design, and appearance as the original.

Lintel. A horizontal structural element spanning the top of a window or door opening, often brick, stone, steel, or wood.

Masonry. Construction using brick, stone, concrete masonry units, or similar units laid in mortar.

Mullion. A vertical structural or dividing element between adjacent window units or panes.

Mortar joint. The visible mortar line between masonry units.

Parapet. The portion of a wall that extends above the roofline, commonly used to conceal flat roofs on commercial buildings.

Period of significance. The span of time during which a historic property or district achieved the characteristics and associations that qualify it as historically significant. For locally, state, or nationally designated resources, the period of significance shall be based on the adopted designation documentation (for example, a National Register nomination, local landmark designation record, or other adopted historic resource record). Where documentation is unclear, the Historic Landmark Commission may determine an appropriate period of significance based on available evidence.

Pier. A vertical structural element of masonry or other material that supports loads and divides bays, often prominent on historic commercial façades.

Punched opening. A window or door opening that appears as a discrete “hole” within a wall plane as opposed to a storefront system with large display glazing.



Recessed entry. A storefront entry set back from the primary façade plane, typically providing weather protection and transition space.

Repointing. The selective removal and replacement of deteriorated mortar in masonry joints, using compatible mortar and tooling.

Rhythm. The repeating pattern of bays, openings, and vertical elements that creates façade organization and a consistent streetscape cadence.

Sash. The operable part of a window that holds the glass, such as a double-hung upper or lower sash.

Secondary frontage. A street-facing building façade that is visible from the public right-of-way but is not the primary street-facing façade. Secondary frontage commonly occurs on corner lots and on lots with frontage on more than one public street. For purposes of these Guidelines, secondary frontage is treated as a street-facing façade and is subject to the applicable street-facing façade requirements, unless a specific guideline states otherwise.

Sill. The bottom horizontal element of a window opening that sheds water outward.

Storefront. The ground-floor commercial façade assembly, typically including display windows, bulkheads, transoms, entry doors, and a sign band.

Transom. A window or glazed panel above a door or display window, often operable historically for ventilation and contributing to storefront transparency.

Through-zone. The portion of sidewalk reserved for continuous, accessible pedestrian travel, kept clear of obstructions.

Tooling. The finished shape and texture applied to mortar joints during installation or repointing.

Transparency. The percentage of a façade area comprised of clear glazing within the defined measurement zone, intended to provide visibility between interior and exterior.

Weathering profile. The shape and detailing of exterior elements designed to shed water, including sills, coping, and cornices.

Wythe. A single vertical layer of masonry units, such as the outer layer of a brick wall.

Section 12.02 Appendix B: Material Palette and Compatibility Guidance

This Appendix establishes preferred material characteristics and provides compatibility guidance for use in both districts, with stricter expectations in the Downtown Historic District. Where this Appendix addresses historic resources, it shall be applied consistent with the Secretary of the Interior's Standards for Rehabilitation.

B.1 Preferred masonry materials.

Brick should be genuine clay brick with natural coloration compatible with Bastrop's historic palette. Highly uniform, glossy, or strongly saturated brick colors are discouraged when they conflict with the established downtown context. Limestone is strongly encouraged and should reflect regional characteristics in color and texture, including natural variation. Locally sourced or regionally compatible masonry materials are preferred where feasible and reasonably available.

B.2 Mortar and repointing compatibility.

Repointing shall use mortar compatible with historic masonry in hardness, permeability, composition, color, and tooling. Mortar that is harder than the historic masonry units is discouraged because it can cause spalling and long-term damage. Joint profiles should match historic conditions where feasible. Repointing should be limited to areas of deterioration and should avoid unnecessarily removing sound mortar.

B.3 Cleaning guidance.

Masonry cleaning should use the gentlest means possible. Abrasive methods that remove the fired surface of brick or damage stone are not appropriate. Chemical cleaners, if used, must be appropriate to the masonry type and fully rinsed to avoid residue.

B.4 Wood and fiber cement.

Wood is appropriate for trim, doors, storefront components, and traditional detailing when properly protected. High-quality fiber cement may be appropriate on secondary façades and in contemporary infill when properly detailed with appropriate reveals, trim thickness, and corner conditions. Thin lap applications that lack shadow lines and durability are discouraged on primary downtown frontages.

B.5 Metal materials and panel systems.

Metal may be appropriate for roofs, canopies, awnings, and architectural panel systems,



especially within the Downtown Bastrop District. Preferred metal applications include standing seam roofing and architectural panels with concealed fasteners, substantial gauge, durable factory finishes, and well-resolved corners and transitions. Corrugated or exposed-fastener “pole barn” style metal siding is discouraged on primary street-facing façades. Metal panel cladding on street-facing façades shall comply with any district caps established in the main Guidelines.

B.6 Glass and storefront framing.

Storefront glazing should be clear and intended to provide visibility. Mirrored, opaque, or heavily reflective glazing is discouraged on primary façades and shall not be used to satisfy transparency requirements. Storefront framing should be robust and appropriately scaled, with visual depth that reads as a storefront system rather than a flush curtain wall unless the building is specifically designed as a contemporary storefront that remains compatible in proportion and rhythm.

B.7 Discouraged façade systems and treatments.

EIFS on ground floors is discouraged. Thin faux-stone veneers and highly synthetic “applied historic ornament” are discouraged, particularly where they create a false historic appearance. Painting of previously unpainted historic masonry is strongly discouraged in the Downtown Historic District and requires a Certificate of Appropriateness when proposed. Abrasive cleaning and coatings that trap moisture in historic masonry are discouraged. For purposes of any required masonry percentage in these Guidelines, fake or synthetic stucco systems (including EIFS and similar systems), split-face block, concrete block, cinder block, and other concrete masonry unit products shall not be counted toward required brick or limestone.

Section 12.03 Appendix C: Historic Color Palette for the Downtown Historic District

This Appendix provides a structured historic color guidance framework for the Downtown Historic District. The intent is to reinforce the historically appropriate character of late nineteenth and early twentieth century commercial downtown buildings while allowing coordinated variation from building to building.

C.1 General palette approach.

Exterior color schemes should be cohesive and restrained and should reflect historic commercial precedents. The preferred approach is a coordinated palette of two to four colors applied in a hierarchy: body, trim/cornice, storefront framing and bulkhead, and door accent. Masonry should remain unpainted where historically unpainted and should function as the dominant “body color” when present. Color and finish selections should be evaluated in relation to the building’s documented period of significance, using materials and colors that are consistent with that period and the established downtown context.

C.2 Preferred body colors for painted surfaces.

Preferred body colors include warm creams, buffs, beiges, taupes, warm grays, soft browns, and similarly muted earth tones. Muted greens and subdued historic blues may be appropriate when used in a restrained manner and coordinated with masonry and trim.

C.3 Preferred trim and storefront framing colors.

Trim and storefront framing may use deeper historic tones, including dark green, charcoal, deep brown, muted navy, and burgundy or oxblood tones. These colors should support architectural articulation and storefront legibility without overwhelming the façade.

C.4 Accent colors.

Accent colors may be used sparingly on doors and minor trim elements. Accent use should be limited to small areas and should not be used as the primary wall color. Highly saturated, fluorescent, or neon colors are not appropriate as dominant wall colors in the Downtown Historic District.

C.5 Prohibited or strongly discouraged applications.

Painting of previously unpainted historic brick or stone is strongly discouraged and requires a Certificate of Appropriateness when proposed. Color schemes that introduce excessively



bright, intensely saturated, or visually disruptive dominant wall colors are not compatible with the Downtown Historic District character.

C.6 Documentation option.

Where feasible, applicants are encouraged to provide paint analysis, scrape sampling, or other documentation that informs historically appropriate selections. Where documentation is not feasible, applicants should provide precedent-based justification aligned with the building's era and downtown context.

Figure 12-1 Example Color Palette

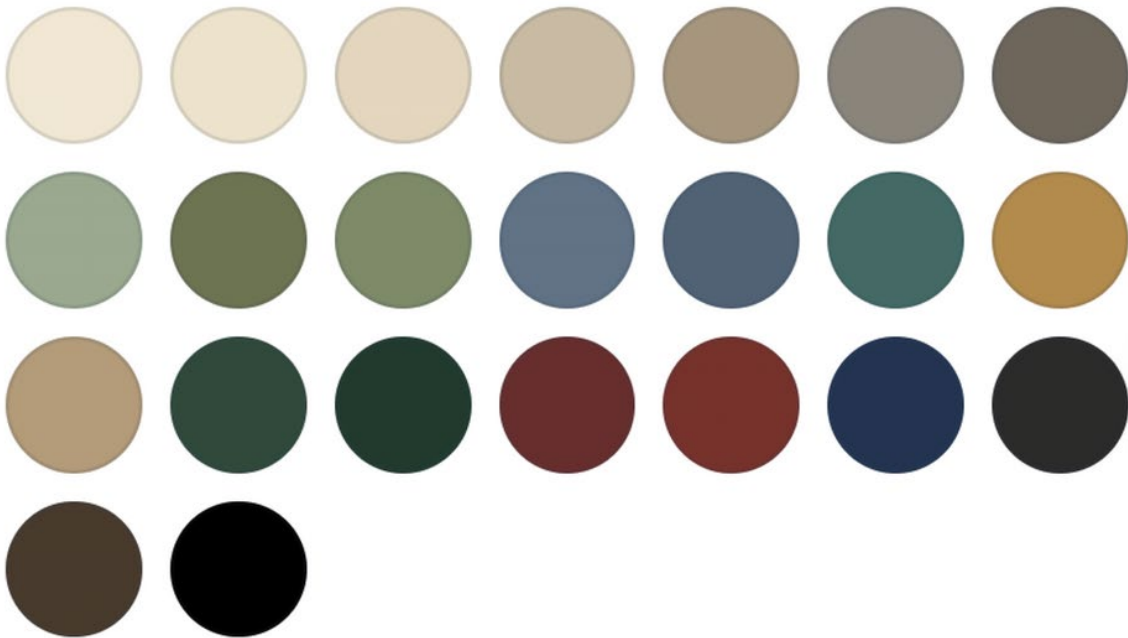

Section 12.04 Appendix D: Example Diagrams and Illustrations

This Appendix may include the figures referenced throughout these Guidelines to support consistent interpretation and enforcement. At a minimum, the City should include the following exhibits as final graphics for adoption: the Downtown Historic District and Downtown Bastrop District map; a transparency measurement diagram showing the two-foot to ten-foot measurement zone and calculation method; an addition placement diagram illustrating the rear-first hierarchy and recommended step-back strategies; a sidewalk zoning diagram illustrating an activation zone and pedestrian through-zone; and sign placement examples illustrating preferred sign types, locations, and illumination approaches. The City may supplement these exhibits with local photographic examples of compliant storefronts, preferred materials, and appropriate contemporary infill.



Section 12.05 Appendix E: Application Forms and Checklists

This Appendix may include application forms and checklists to standardize submittals and ensure predictable review. Forms should include an administrative approval request form, a sidewalk café or encroachment permit application if applicable, a Certificate of Appropriateness application for Downtown Historic District and designated historic resources. Checklists should address required photos, context documentation, elevations, material and color schedules, product cut sheets, transparency calculations, and any district-specific requirements.



Section 12.06 Appendix F: District Maps

This Appendix shall include the officially adopted Downtown Historic District map and Downtown Bastrop District map as controlling exhibits. The maps should clearly depict district boundaries, identify primary streets, and provide sufficient reference information to allow a property owner to determine whether a property is within a district. Where feasible, the maps should include parcel lines and street names, and should reference the City's official GIS layers as the administrative source for interpretation.

Figure 12-2 Downtown Historic District

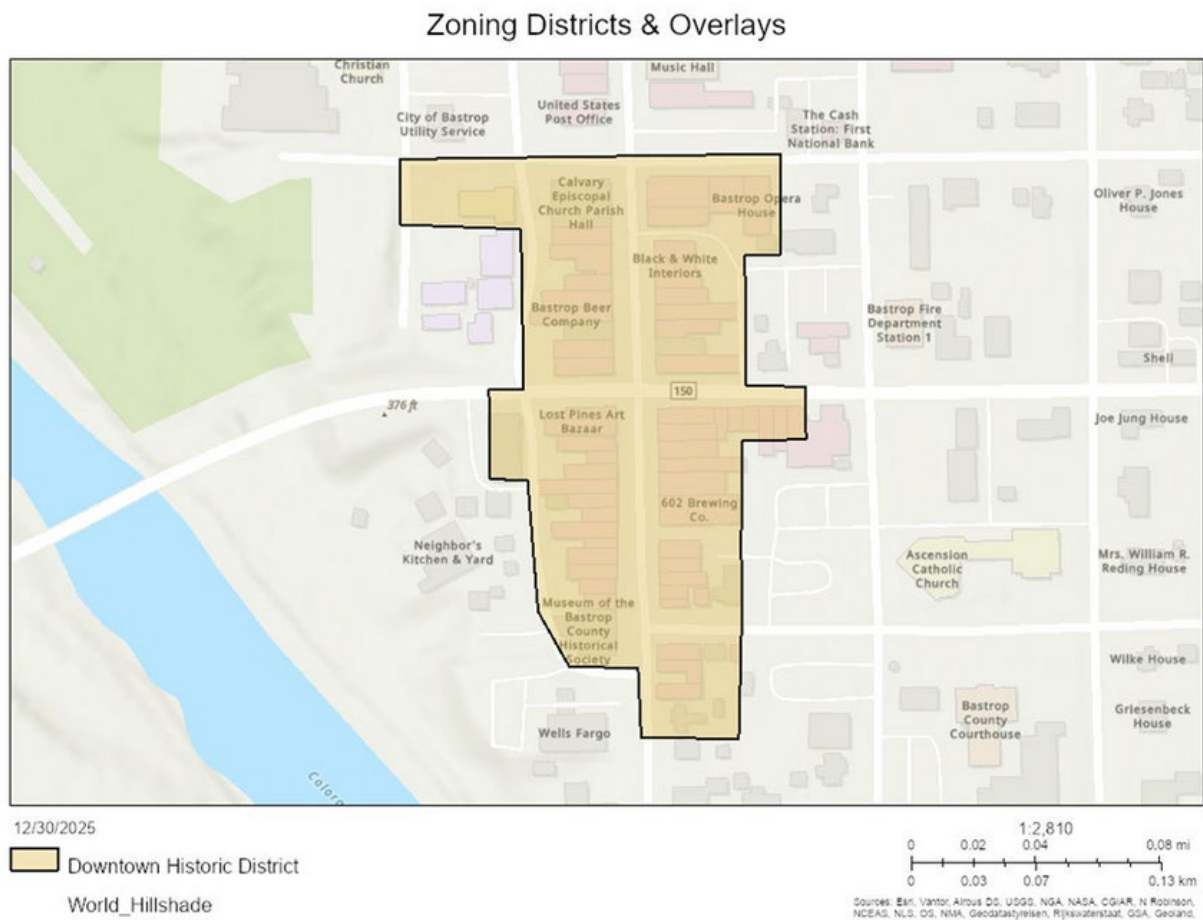
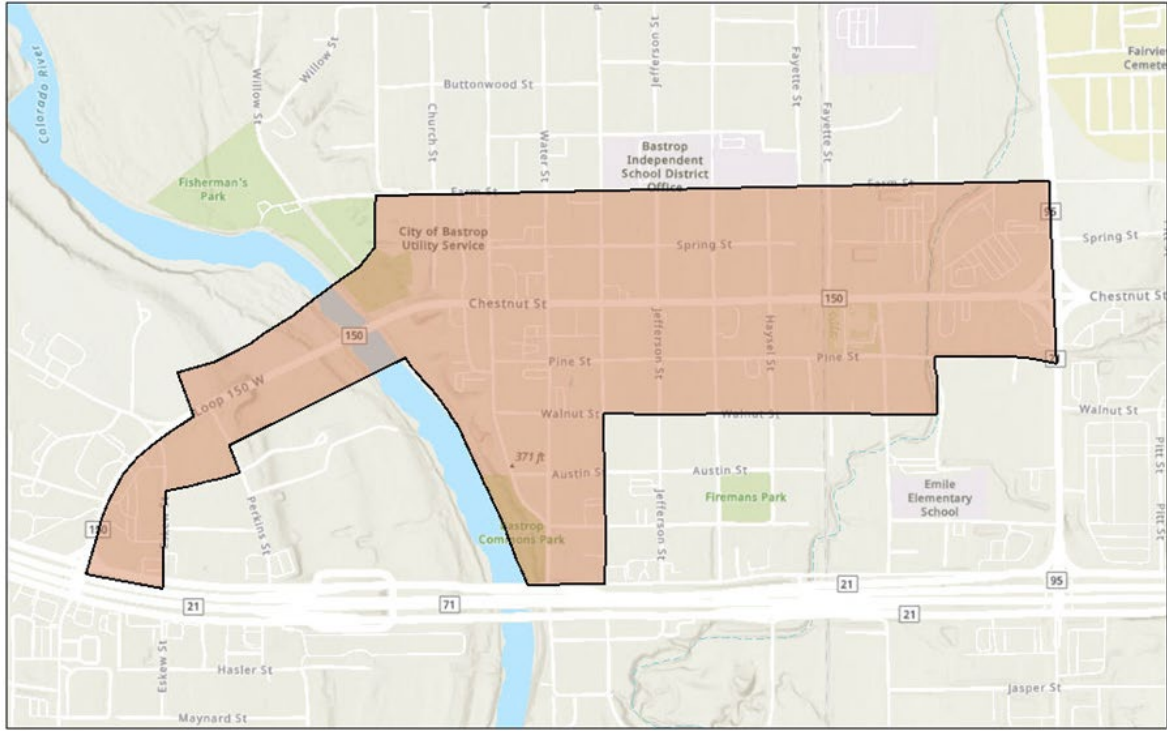

Figure 12-3 Downtown Bastrop District

Zoning Districts & Overlays



12/30/2025

 Main Street Program Area

World_Hillshade

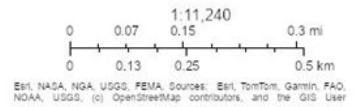

Section 12.07 Appendix G: Secretary of the Interior’s Standards Summary

This Appendix summarizes the Secretary of the Interior’s Standards for Rehabilitation to support consistent applicant understanding, staff findings, and Historic Landmark Commission decisions. The Standards are applied to guide repair, alteration, and additions to historic properties in a manner that preserves historic character while allowing continued use and reinvestment. Where the Standards are incorporated by reference or required by ordinance, the Secretary of the Interior’s Standards themselves shall govern.

G.1 Core Principles for Downtown Rehabilitation

Rehabilitation work in the historic district should be planned and executed to:

- **Retain historic character.** Protect the overall form, scale, and defining appearance of the building and streetscape.
- **Preserve distinctive materials and features.** Maintain original or historic elements such as storefronts, windows, doors, masonry, cornices, parapets, trim, and detailing.
- **Repair rather than replace.** Stabilize and repair historic materials where feasible. When replacement is necessary, match the original in design, material, texture, and, where possible, workmanship.
- **Avoid “false history.”** Do not add features or finishes that create a misleading sense of historic development, such as conjectural details or incompatible “period” elements not supported by evidence.
- **Design additions to be compatible but identifiable.** New work should be clearly differentiated as contemporary, while remaining compatible in massing, scale, proportion, rhythm, materials, and context.



G.2 The Ten Standards

Standard 1. Use and overall character. A historic property shall be used as it was historically, or be given a new use that requires minimal change to the defining characteristics of the building and its site. In a downtown context, this standard supports adaptive reuse that retains the traditional storefront-and-upper-façade relationship and preserves the historic street presence.

Standard 2. Retention of historic character. The historic character of a property shall be retained and preserved. The removal of historic materials or alteration of features and spaces that characterize the property shall be avoided. For Main Street commercial buildings, this includes preserving character-defining storefront components, masonry, parapets, cornices, and the rhythm of openings.

Standard 3. Avoidance of false history. Each property shall be recognized as a physical record of its time, place, and use. Changes that create a false sense of historical development, such as adding conjectural features or elements from other buildings or periods, shall not be undertaken. This standard discourages “fake historic” treatments and requires that rehabilitation decisions be grounded in evidence and context.

Standard 4. Preservation of later historic changes. Changes to a property that have acquired historic significance in their own right shall be retained and preserved. In practice, this means later alterations that are themselves historic and contributory should not be removed simply to pursue an earlier appearance.

Standard 5. Preservation of distinctive materials and craftsmanship. Distinctive features, finishes, and construction techniques or examples of craftsmanship that characterize a property shall be preserved. For downtown buildings, this includes masonry detailing, original storefront framing patterns, historic window proportions, pressed metal elements, and other period workmanship.

Standard 6. Repair rather than replacement. Deteriorated historic features shall be repaired rather than replaced. Where the severity of deterioration requires replacement of a distinctive feature, the new feature shall match the old in design, color, texture, and, where possible, materials. Replacement of missing features shall be substantiated by documentary, physical, or pictorial evidence. This standard is central to storefront rehabilitation, window work, parapet repair, and masonry maintenance.

Standard 7. Gentle treatment of historic materials. Chemical or physical treatments, such as sandblasting, that cause damage to historic materials shall not be used. Surface cleaning of structures, if appropriate, shall be undertaken using the gentlest means possible. In downtown masonry, this standard supports non-abrasive cleaning and compatible mortar repointing that does not damage brick or stone.

Standard 8. Protection of archeological resources. Significant archeological resources affected by a project shall be protected and preserved. If such resources must be disturbed, mitigation measures shall be undertaken. In a downtown setting, this can apply to excavation associated with additions, utilities, site work, and paving.

Standard 9. New additions, exterior alterations, and related new construction. New additions, exterior alterations, or related new construction shall not destroy historic materials that characterize the property. The new work shall be differentiated from the old and shall be compatible with historic property and its setting.

Standard 10. Reversibility. New additions and alterations should be designed so they can be removed in the future without impairing the essential historic form and integrity of the building.